

**THE POLARISCOPE IN THE
CHEMICAL LABORATORY**

•The  Co. •

THE POLARISCOPE
IN THE
CHEMICAL LABORATORY

AN INTRODUCTION TO POLARIMETRY AND
RELATED METHODS

BY

GEORGE WILLIAM ROLFE, A.M.

INSTRUCTOR IN SUGAR ANALYSIS IN THE MASSACHUSETTS INSTITUTE
OF TECHNOLOGY



New York
THE MACMILLAN COMPANY
LONDON: MACMILLAN & CO., Ltd.
1905

All rights reserved

COPYRIGHT, 1905,
BY THE MACMILLAN COMPANY.

Set up and electrotyped. Published September, 1905.

Norwood Press
J. S. Cushing & Co. — Berwick & Smith Co.
Norwood, Mass., U.S.A.

PREFACE

THE immense importance of the sugar industry in world economics has forced the development of the polariscope into a sugar-testing instrument of high efficiency. Comparatively few practicing chemists are familiar with any other application of this useful laboratory tool.

Many books have been written on commercial saccharimetry, but it is only by hunting through the whole mass of literature of analytic chemistry that occasional instances can be found of the application of the polariscope in general laboratory practice.

Landolt's great work is the only one devoted to a complete treatment of the subject of polarimetry, but that is, in the main, a book for the physical chemist and trained investigator in pure science.

Hence I have ventured to write a simple introductory treatise, not a complete manual of polarimetry by any means, but one explaining in an elementary way fundamental principles and their application in general laboratory practice.

Naturally, I have devoted much space to methods in use in sugar manufacture, but have also described those used in brewing, the starch industries, and food and drug analysis as well. It has seemed best to introduce outlines of some technical processes and factory methods of chemical control to make the subject clearer. I have also overstepped the strict bounds of polarimetry to explain methods obviously accessory to many determinations.

A sketch of the use of the polariscope in pure science is given in view of the great possibilities of the instrument in that field.

In short, with an experience covering nearly twenty years as technical chemist in the sugarhouses of the West Indies, in the glucose industry of the West, and as a teacher of polarimetric methods in a great technical school I offer the book in the hope that it may prove a guide to a better comprehension of the polariscope as a practical laboratory tool, and suggest means of wider application.

I can make but small return here in acknowledging my indebtedness to those who have kindly assisted me in the preparation of these pages,—to my father, Dr. W. J. Rolfe, whose criticism and advice has been an inestimable aid in putting this book through the press; to Professor F. H. Storer, an esteemed critic, but more than all, one whose kindly interest and encouragement have greatly heartened me in my task; to my colleagues, Professors Wendell, Noyes, Gill, Mulliken, Mr. A. G. Woodman, and others who have aided me with advice and criticism in their special fields of work.

CONTENTS

	PAGE
FUNDAMENTAL PRINCIPLES	1
THE POLARISCOPE	15
THE SACCHARIMETER	28
ACCURACY OF SACCHARIMETER MEASUREMENTS	39
GENERAL NOTES ON APPARATUS AND LABORATORY MANIPULATION	48
NOTES APPLYING TO SPECIAL INSTRUMENTS	68
POLARIZATION OF CANE SUGAR—GENERAL COMMERCIAL METHODS	87
DETERMINATION OF SUCROSE IN PRESENCE OF OTHER OPTICALLY ACTIVE SUBSTANCES (DOUBLE POLARIZATION)	101
SUGARHOUSE AND REFINERY METHODS	111
CHEMICAL METHODS OF DETERMINING SUGARS	160
STARCH AND STARCH PRODUCTS	173
MISCELLANEOUS SACCHARINE PRODUCTS	222
APPLICATION OF THE POLARISCOPE IN SCIENTIFIC RESEARCH	238
APPLICATION OF THE POLARISCOPE TO CHEMICAL ANALYSIS OTHER THAN CARBOHYDRATE DETERMINATIONS	260
APPENDIX	279
TABLES	285
INDEX	315

THE POLARISCOPE IN THE CHEMICAL LABORATORY

FUNDAMENTAL PRINCIPLES

The Function and Scope of Optical Analysis. The methods of analysis to be described are based on the behavior of "polarized light" in passing through sugar solutions. In many cases these methods can be applied as well to other "optically active" compounds that are in the liquid state or in solution. Many organic substances show optical activity—about seven hundred have been studied: hydrocarbons, such as diamyl; alcohols, as dichlorhydrin; acids, like tartaric; alkaloids, as nicotine; essential oils, as oil of lemon; and terpenes, like camphor.

Comparatively little is known about the relationship of optical activity to the chemical and physical structure of matter. Pasteur, about 1850, pointed out that the optical behavior of solutions of isomeric forms of tartaric acid could be foretold by a study of the planes on the crystals of these acids. This relation has been found to hold true in case of other organic crystals. An analogous law had been discovered in quartz crystals by Herschel, in 1835. Van't Hoff and Le Bel, in 1874, showed that differences in the optical activity of isomers could be explained by a peculiar molecular structure and demonstrated by the graphic symbolism ordinarily used in interpreting organic

reactions.¹ This theory has been useful in predicting the existence of many organic compounds, and may be said to form the basis of the scheme of Fischer's masterly researches on the sugars.²

While it is not the province of this book to go into an elaborate exposition of the properties and theories of polarized light, it is necessary, for the intelligent use of apparatus and the understanding of methods, to describe a few simple experiments, with brief explanations.

Double Refraction. — "Iceland spar," a crystallized calcium carbonate, which in the natural mineral readily splits up into colorless rhombohedrons, is the customary material used in optical instruments for producing plane polarized light. Looking through such a rhombohedron of Iceland spar in any direction (except parallel to a line joining the two most obtuse solid angles, known as its "optical axis") it will be noticed that the images of objects are *doubled*. Evidently the light passing through the crystal follows two paths. This "double refraction" is characteristic of any crystal not "isometric" in structure, but any transparent solid, ordinarily not doubly refractive, glass for instance, will show double refraction if different parts are subjected to unequal pressure, thus producing variations of density.

The Nicol Prism. — In a substance showing double refraction, each member of the divided beam in its passage

¹ A review of the work of Pasteur and bibliography of original papers will be found in Landolt's "Das optische Drehungsvermögen," p. 40. A similar review of the work of Van't Hoff and I. e. Bel begins on p. 43 of the same work. Pasteur's original paper has also been recently published in the "Alembic Club Reprint," No. 14.

² Outlined by Tollens, "Handbuch der Kohlenhydrate," II, 11-40.

through the crystal has undergone a remarkable change, known as "polarization," which makes it available in sugar analysis. To utilize this property it is necessary to isolate one of these beams, which can be done by a "Nicol prism," so called from its inventor.

Such a prism is made from a rhomboidal piece of Iceland spar, one whose length is approximately three times its breadth, by grinding and polishing the end faces so that they make an angle of 68° with the long edges instead of the 71° of the original crystal, and cutting the crystal in halves along a plane passing through one of the most

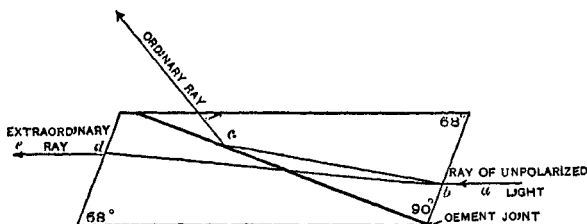

FIG. 1.—DIAGRAM SHOWING PATHS OF LIGHT RAYS IN A NICOL PRISM.

obtuse solid angles of the prism 90° to the modified end faces. The cut surfaces are polished, and cemented together with Canada balsam, restoring the two parts of the crystal to their original positions. The long side faces of the prism are blackened.

Any ray of light on entering a Nicol prism in a direction parallel to the long edges is divided into two components. The component most refracted, known in this case as the "ordinary ray," meets the balsam sheet at such an angle that it is totally reflected, and practically all absorbed by the dark coating of the sides of the prism. The other ray, called the "extraordinary," striking the balsam plane at a

lesser angle, passes through the prism, emerging in a condition which is known as "plane polarized."¹

Properties of Plane Polarized Light. — Looking through two Nicol prisms at any source of light, holding the prisms so that the light will pass through each successively, and revolving one slowly on its long axis, — that is, around the line of direction of the light beam, — it will be noticed that the light seen through the prisms *varies* continually as the prism turns. At certain points in the revolution of the prism, 180° apart, *no* light passes, while at exactly *midway* between these positions (90° from them) *most* light is seen. As the prism is revolved, the light increases up to a maximum, and then decreases till the point of "total extinction" is reached. Hence, the *amount of light* passing through such a combination of Nicol prisms in the manner described depends on the *angle* through which one of the prisms is rotated from the positions giving maximum or minimum illumination. The relative positions of the Nicols giving *maximum* light intensity will be found to be that point of rotation when the rhomboids of the end faces are *parallel*, each edge of the end face of one prism to the corresponding edge of the other prism. When one of the Nicols is rotated to a position 90° , *no* light passes, and the field is dark. In the first case, the prisms are said to be "parallel," in the second "crossed."

Polariscope. — If the combination of prisms as described is held in some suitable apparatus, one prism being fixed, the other capable of rotation, a measuring device can be

¹ Some modified forms of the Nicol, designed to increase its light capacity, are described in Landolt's work already referred to.

ected to the rotating prism and these phases of light
ensity, or light effects depending on them, can be re-
red to definite points on a scale. Such an instrument
alled a "polariscope," and can be utilized in sugar
lysis. A *sugar solution*, placed between the prisms in
ch a way that the light passes through it in its passage
etween the prisms, *affects the intensity* of the light, so that
will be necessary to *rotate* the movable prism to restore
y light effect shown by the polariscope previous to the
section of the solution. The *magnitude of the angle*
rough which the prism must be rotated to restore the
iginal light effect is found to depend directly on the *con-*
centration of the sugar solution, and therefore can be taken
a measure of the sugar itself.

Undulatory Theory. The so-called "undulatory" or
wave" theory has proved indispensable for interpreting
ese phenomena of polarized light. In its simplest form
is theory assumes that all light rays are caused by waves
f energy transmitted in straight lines through a medium,
alled "ether," which pervades all space, even dense
olids.

The transmission of energy in transverse waves propa-
ated in straight lines can be admirably illustrated by
means of a stretched elastic cord. If one end of such a
ord is vibrated transversely by shaking it at right angles
o the direction in which the cord is stretched, waves will
ass along the cord, as each particle is successively set in
oscillation. Obviously it is the disturbance that travels as
a wave and not the matter in the cord itself, each particle
f which is merely oscillating backward and forward. If
he cord is continuously shaken in different directions

transverse to its length, it illustrates well the theoretical conception of ordinary light.

The direction in which the cord is stretched is the straight line which determines the path of transmission of the waves and corresponds to the light ray. The particles, always oscillating transversely, but whose planes of vibration are continually changing their position in space, illustrate the ether.

For such a series of transverse waves see the diagram. Two particles moving in the same direction at the same time, such as *A* and *B*, are said to be in the "same phase."

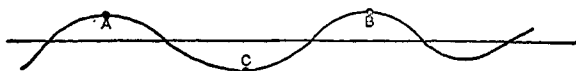

FIG. 2.

When the displacement and motion of the two vibrating particles are exactly opposite, as *A* and *C*, they are said to be in "opposite phase." A "wave length" is the distance along the line of transmission between the two nearest particles in the same phase, as from *A* to *B*. The distance from one particle to the next in opposite phase is half a wave length. A ray, representing the direction of transmission (path), of the energy is a geometric line and hence has but one dimension. A multitude of rays having a common direction is called a "beam," and can be considered to occupy space. These terms are also loosely used by many writers on optics to express the waves of energy themselves which are moving in a ray or beam.

The *color* of the light depends on the period of vibration of its waves. In the passage of the light through any homogeneous medium, as air, its color bears a direct

relation to its wave length. Light consisting of waves of one length is said to be "homogeneous" or "monochromatic," its color being expressed mathematically in terms of its wave length when passing through air. Light made up of vibrations of many wave lengths is said to be "compound"; ordinary day or lamplight is of this nature.

[See Preston's "Theory of Light" for a full explanation of wave propagation and exposition of the undulatory theory in its application to optics.]

Reverting to the phenomena observed with the two Nicols: when light enters a Nicol prism, owing to the molecular structure of the calc-spar, the ether is prevented from vibrating in varying planes, its oscillations being confined to *two* at right angles to each other. Application of the law of resolution of motions will greatly assist in understanding the theoretical explanation of these light phenomena. Many of the effects of Nicol prisms can be made clear by making a diagram of the vibration planes according to the doctrine of the "parallelogram of forces."

In the Nicol prism, the theory shows that the planes of vibration of the two light beams are determined by the diagonals of the end faces. It has been shown how one of these beams has been disposed of by total reflection. The plane of vibration of the unextinguished (emerging) beam is parallel to a plane passing through the shorter diagonals of the end faces of the prism. A plane at right angles to this is known as the "plane of polarization." The rays of the emerging beam from a Nicol prism, after emergence, continue to vibrate only in the definite vibration plane, determined by the position of the shorter diagonals of the

end faces of the prism, and are not, like ordinary light, continually changing their vibration planes. It is this characteristic of the light which distinguishes it, in the interpretation of the theory, as "plane polarized."

In the combination of the two Nicols as described, the plane polarized beam emerging from the first Nicol, having one resultant vibration plane, passes into the second Nicol, where it is in general resolved into two plane polarized beams, one of which is reflected out. The *amount* (intensity) of light which will pass through the second prism can be determined when the angle which its vibration plane makes with that of the first prism is known, by making a diagram of the positions of the vibration planes of the emerging beams of the two Nicols as follows :

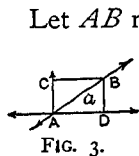

FIG. 3.

Let AB represent the vibration plane of the light emerging from the first Nicol (which is known as the "polarizer"), and AD that of the emerging beam from the Nicol nearest the eye (the "analyzer"), this latter plane making the angle α with the plane of the polarizer.

The beam defined by AB is divided, on entering the second Nicol, into two components whose vibration planes are AD and AC , of which only the beam defined by AD can emerge from the analyzer. Its *intensity* as compared with the light passing through the polarizer is represented by $\frac{AD}{AB}$, the relative lengths of AD and AB being determined by completing the parallelogram $ACBD$.

When the Nicols are *crossed* (that is, when AB is perpendicular to AD), it will be seen that the light emerging from the polarizer is passing along a vibration plane in

such a position that the waves are totally reflected by the analyzer, and the field is black, or, in actual experiment, of minimum intensity, since usually not quite all the rays entering the prisms are parallel.

It is true that this assumption of light waves is purely a theoretical one. It is equally true that scientists guided by these ideas have made actual laboratory measurements which logically seem to represent light-wave measurements. Reference will be made to some of these values, which are actualities of physics, whatever their interpretation.

Effect of Sugar Solutions on Polarized Light. — (1) If the light passing through a polariscope is of one wave length, that is, "homogeneous" or "monochromatic," as is, practically, the yellow light made by vaporizing table salt in a Bunsen burner, and a *tube filled with sugar solution* is placed between the two Nicols, so that the light passing from one prism to the other has to traverse the length of the tube through the solution, the following results will appear: if the Nicols are *crossed*, total extinction does not now occur, but the extinction point now will be found by rotating the analyzer to the *right* (in the direction of the motion of the hands of a clock).

(2) If the light is *ordinary daylight* or lamplight, that is, white light, made up of light of all wave lengths ("compound light"), it will be seen that extinction does not take place at any position of the analyzer, but the field of view is colored, all the spectral colors appearing as the analyzer is rotated.

The explanation of these light effects is that the planes of vibration of the light waves of different lengths are *rotated to the right* by the sugar solution, but not all to

the same extent; those of the shortest length, namely the violet, being turned the most, the red the least.

At each position of the rotating Nicol the planes of vibration of *some* of the rays, those of some definite tint (wave length), make an angle of 90° with the principal section of the analyzer, and are consequently reflected and absorbed. The light emerging from the analyzer is, therefore, the original light *deprived of the color of these reflected rays*, or "complementary" to them. In the case where the light is monochromatic, as is, practically, the sodium flame, *total extinction* occurs when the rotating Nicol is turned so that its vibration plane is at right angles to the rotated plane of vibration of the beam passing into it from the sugar solution. But one such plane exists, as all the rays having a common wave length are rotated alike.

It follows that if the rotatory effect of a sugar solution on plane polarized light is to be measured, it is necessary to use *monochromatic* light.

This behavior of the sugar solution is called its "optical activity." Any optically active substance in solution will affect plane polarized light in a similar way, rotating the planes of vibration to the right in some cases, to the left in others. Substances rotating to the right are known as "dextrorotatory" (symbolized +); those to the left, "levorotatory" (-).

Laws governing Rotation of Optically Active Substances. — In the experiment just described, when the light is monochromatic, the angle of rotation of the vibration plane of the plane polarized light by a sugar solution can be measured by the angle through which the analyzer of the polariscope must be turned to restore the original light

effect given by the instrument previous to placing the sugar solution between the prisms (in the case described, total extinction). This can be demonstrated by means of a diagram analogous to Fig. 3.

The stronger the sugar solution and the longer the column through which the light passes, the greater the angle through which the vibration plane is turned. Experiment has shown that, for rays of any one wave length, this rotation is *directly proportional to the concentration and length of column of the solution.*

Specific Rotatory Power.—When the angles of rotation of different optically active substances are compared under identical conditions of concentration, column length, and light, each substance gives a characteristic value. When determined under *standard* conditions, the characteristic angle obtained is a measure of the “specific rotatory power” or “specific rotation” of the substance, and is symbolized by the Greek letter *alpha* (α). In modern measurements, the specific rotation of solutions of optically active substances is measured by the *angle of rotation, expressed in angular degrees, which plane polarized light, corresponding in wave length to that of the yellow, D, line of the solar spectrum,¹ undergoes in passing through, at a temperature*

¹ As there are two lines given by sodium light, D_1 and D_2 (the latter much brighter), in the most exact measurements the ray midway between the two spectrum lines is taken as the standard, having a wave length of .000589.32 millimeter. Such light, according to Lambert, is produced from a sodium chloride flame after passing the rays successively through solutions of potassium bichromate and uranium sulphate.

The light of the D lines of the solar spectrum separated by spectroscopic methods has a resultant wave length or “optical centre” of .00038925 millimeter and gives rotation values identical within the usual limit of the measurements with those taken by the Lippich filtered sodium light.

of 20°C. , a decimeter column of a solution of the optically active substance having a concentration of one gram in one cubic centimeter. This can be expressed by the following equation:

$$a = \alpha l c, \quad (1)$$

where a is the angle of rotation in *degrees*, l the length of column in *decimeters*, and c the concentration. If there are w grams of substance in v cubic centimeters of solution, the concentration can be expressed as $\frac{w}{v}$.

Hence,
$$a = \frac{\alpha l w}{v}, \quad (2)$$

and
$$\alpha = \frac{a v}{l w}. \quad (3)$$

By this last equation, the specific rotatory power of any optically active substance can be calculated from solutions of any convenient concentration if the column length is known. As will be seen later, effects so obtained in many cases have to be corrected for influence of solvent and temperature, but for cane sugar these effects are practically negligible for ordinary conditions of analysis. These specific rotation values are the fundamental constants of all calculations in optical analysis, being analogous in their use to the atomic weights in the usual computations of gravimetric and volumetric analysis.

If the concentration of a solution is expressed in percentage of substance in solution (grams in 100 grams), as is often the case in commercial analysis, equations (2) and (3) are expressed somewhat differently. The number of grams in 100 grams can be expressed as p , and since, if d represents the density of the solution, $v = \frac{100}{d}$, $\therefore \frac{w}{v} = \frac{p d}{100}$.

Hence,
$$a = \frac{\alpha l \rho d}{100}, \quad (4)$$

and
$$\alpha = \frac{100 a}{l \rho d}. \quad (5)$$

Obviously it is necessary to distinguish carefully between these two expressions of concentration, in order to avoid serious confusion in calculations.¹

Yellow light, corresponding to the *D* line of the solar spectrum, has been adopted for the standard because of the ease with which light of this color can be produced by volatilizing table salt in a Bunsen burner, alcohol lamp, or other source of hot non-luminous flame. Specific rotations so determined are more exactly symbolized $[\alpha]_D$ to distinguish them from others to be referred to.

In the case of an optically active substance which is itself a *liquid*, as, for instance, spirits of turpentine, the specific rotatory power is expressed by the equation

$$\alpha = \frac{a}{ld},$$

where *d* is the density of the liquid.

In the case of an optically active transparent *solid*, as quartz, $\alpha = \frac{a}{l}$, the unit for *l* being a section one millimeter thick cut in a plane at right angles to the optic axis. The standard temperature for all specific rotations is 20° C.

¹ In very accurate determinations of specific rotation the concentration is expressed in percentage of substance in solution, both substance and solvent being weighed and all weights being absolute, that is, calculated for weighings in a vacuum. In the case of the weight of a solid substance of the density of cane sugar the difference between the weighings in air and the absolute is only 0.01%.

Application of the Laws of Optical Rotation to Sugar Analysis. — The application of these laws to the analysis of sugar or other optically active substance can now readily be understood. Let P be the per cent of optically active substance contained in $\tau w'$ grams of sample, the weight of this optically active substance being w .

Then, $P = \frac{w}{\tau w'}$, P being expressed decimally.

From the fundamental equation already given :

$$w = \frac{\alpha \tau}{\alpha'}.$$

Then,
$$P = \frac{\alpha \tau}{\alpha' \tau w'}$$

For example, 17.50 grams of raw sugar in water solution, made up to 100 cubic centimeters, observed in a 2-decimeter tube, rotated the plane polarized yellow ray $21^{\circ} 35'$. Taking the specific rotation of cane sugar as 66.5° and expressing all values in *standard units*, the percentage of cane sugar can be expressed as follows :

$$\frac{21.58 \times 100}{2 \times 66.5 \times 17.50} = .9272^1 \text{ (that is, } 92.7\% \text{)}.$$

If the substance has its rotation constant appreciably affected by the amount of solvent present, as is the case with camphor or tartaric acid, the calculation will be more complicated. Under the ordinary conditions of commercial sugar analysis, this influence is so small as to be negligible, as already stated.

¹ Throughout this discussion it is, of course, assumed that but one optically active substance is present in solution.

THE POLARISCOPE

Essential Parts. — From the preceding chapter it is clear that the essential parts of a polariscope for measuring the rotatory effects of optically active substances are two Nicol prisms, one of which must be capable of rotation and have some suitable device for measuring the angle of its rotation from a definite position. These prisms must be arranged, as previously described, in a suitable holder, so that tubes containing solutions to be examined can be placed between the prisms, and finally there must be some source of monochromatic light.

As a rule the analyzer is the rotating prism, as this brings the measuring scale conveniently near the eye of the observer.

In 1840 Biot introduced a polariscope of this description, using the total extinction position of the prisms for the end point; but, as experiment with such an instrument will show, it was impossible to determine the exact point of extinction without a large error. In the optical devices for producing a more precise end point, much ingenuity has been expended; in fact, these devices alone determine the essential differences between most of the different makes of polariscopes for measuring angles of rotation directly.

Mitscherlich Polariscope. — Mitscherlich, in 1844, improved the original instrument of Biot, so that a broad

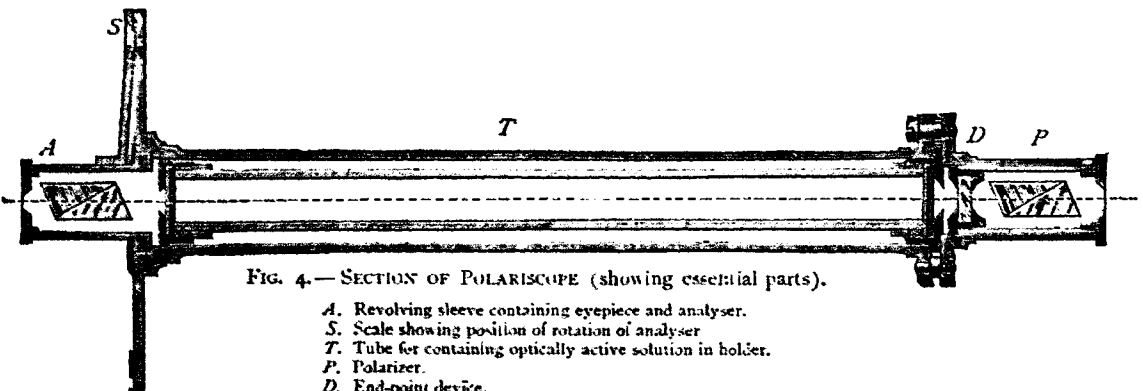

FIG. 4. — SECTION OF POLARISCOPE (showing essential parts).

- A. Revolving sleeve containing eyepiece and analyser.
- S. Scale showing position of rotation of analyser
- T. Tube for containing optically active solution in holder.
- P. Polarizer.
- D. End-point device.

black band in a light field was produced at the extinction point, instead of total darkness. The Mitscherlich polariscope is still used for comparatively rough measurements, being sensitive to $.1^{\circ}$.

The Transition-tint Polariscope...... Another end-point device, used in the earlier instruments by Biot and others, was the "transition-tint" quartz plate. Sections of quartz, cut perpendicular to the optic axis of the crystal, have a strong rotatory effect on plane polarized light when the light passes parallel to the optic axis, some crystals turning the plane of polarization to the right (clockwise), others to the left. The direction in which the planes of vibration rotate can be predicted by a study of the arrange-

ment of the faces of the original crystal. The amount of rotation is independent of the right or left direction, but depends on the thickness of the quartz section. A millimeter section of quartz, according to Biot, rotates plane polarized light of different colors about as follows :

Red, 19° Yellow, 24° Green, 28° Violet, 41°

These values are for "mean" rays, or those approximately in the middle of the spectrum bands of the colors mentioned, and do not apply to the "Fraunhofer" lines as do the more exact measurements of later observers.

The transition-tint plate consists of two quartz sections, cut as described, of equal thickness, but of opposite rotations. These are mounted in a diaphragm opening between the polarizer and analyzer, in such a way that each section covers half of the optical field of the polariscope. The sections are cut 3.75 millimeters thick, and rotate the mean yellow rays 90° ($3.75 \times 24 = 90$), which in consequence cannot pass through the analyzer when its plane of polarization is parallel¹ to that of the polarizer. White, or any light containing rays of all wave lengths, as lamp or gas light, in passing through such an optical combination will be deprived of its yellow rays, and the optical field will show, accordingly, the resulting "complementary" tint, usually described as a rose violet. If the analyzer is turned in the least, contrasting tints of red and blue are seen in opposite halves of the field. Only at the end point, or at a position of the analyzer 180° from it, do

¹ A section cut any odd multiple of 3.75 millimeters in thickness will produce the same effect. When the plate is cut an even multiple, it is easily demonstrated that the transition tint appears when the Nicols are crossed.

both halves of the field show the same tint, — this rose-violet transition tint.

The transition-tint polariscope was introduced by Robiquet, and was much used by earlier investigators, as it was more sensitive than the Mitscherlich, and had the advantage of using ordinary light.

Inasmuch as this instrument gave measurements of the rotation of the vibration plane of the mean yellow ray, and not that of the D line of the sodium flame, it gave rise to statements of rotation figures on a different standard, which is distinguished by the symbol $[\alpha]_j$, the mean yellow ray of wave length .0005608 millimeter, being known as the j ray (French *jaune*, yellow).

The transition-tint polariscope is not now used in scientific measurements, although the transition-tint plate is the end-point device of some modern saccharimeters. The instrument has many disadvantages. Colored solutions obviously interfere with its readings. Many colorless solutions of high rotation produce dispersive disturbances which prevent an even-tinted field at the end point. It has been objected to on the ground that lights of different wave-length composition, such as daylight and gaslight, give slightly different complementary tints. The instrument is of course useless to those who are color-blind. A cheap form of this polariscope is used in Europe somewhat for determining sugar in wines, as the errors of such low rotations are inconsiderable.

The transition-tint polariscope — which must not be confounded with the Soleil saccharimeter — is of importance to the modern investigator solely because the optical constants which were obtained by its measurements are still

found in many modern works, especially English, and consequently the difference between specific rotatory powers expressed by $[\alpha]_D$ and $[\alpha]_j$ should be understood. Inasmuch as the rotation for the D line of the spectrum by a millimeter section of quartz is 21.7° , that of the mean yellow being 24° , as previously stated, the old transition-tint constants can be changed to the modern standard by the factor, $\frac{21.7}{24.0}$.

Practically all modern polariscopes use the sodium light, and have some device which shows a blank, evenly illuminated field at the end point, while at any other position of the analyzer, a part of the field, usually one half, is shaded. One of the earliest of these "shadow" or "half-shade" polariscopes was devised by Jellet about 1860. Cornu and Duboscq improved the instrument in some details of its construction.

The Duboscq Half-shade Rotatometer.—The end-point device of the Duboscq half-shade "rotatometer," as it is called, is the Jellet-Cornu or "split" prism, which takes the place of the ordinary polarizer. This is made by bisecting a Nicol prism, or one of its sections, *lengthwise* of the

¹ Some confusion has resulted from the introduction by Montgolfier in 1874 of a *jaune moyen* ray, having a rotation value of 24.5° for the quartz millimeter plate, subsequently adopted by Landolt in his book on the polariscope as the value for the j measurements. This ray is not the Biot ray, intermediate in *wave-length* value between the sodium and thallium lines of the solar spectrum and having a wave length of .0005608 millimeter, but is the ray of a wave length .0005553 of a rotation value for the quartz millimeter plate which is the *arithmetical mean* between the *rotation* values for the D ray and the E ray. This later change of standard was most unfortunate, as it has caused a misunderstanding which has marred much excellent work by early investigators [*J. Chem. Soc.*, 1897 (71), 89].

prism, in the plane passing through the shorter diagonals of the end faces. Equal wedge-shaped sections are taken off the two cut surfaces, and the two parts are cemented together again. The effect of the removal of the two wedge-shaped sections is to tilt the polarizing planes of the two halves of the prism so that they make an angle (usually about 175°) with each other. This type of prism is made in several ways, but the principle is the same in every form.

This modified prism is used as a polarizer, and is mounted in the polariscope with a diaphragm having a circular opening between it and the analyzer in such a way that the opening is bisected vertically by the line of the joint of the two halves of the prism. If the *analyzer* is turned to a position which would give total extinction for an instrument fitted with an ordinary Nicol for a polarizer, the field made by the diaphragm opening will not be black in this case, but *faintly and evenly illuminated*, appearing as a luminous disk. The slightest rotation of the analyzer from this position produces a shading in one or the other halves of the field. This can be made clear by a discussion of the following diagram :

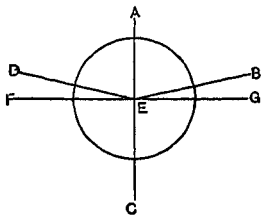

FIG. 5.

Let AC and FG respectively represent the positions of the planes of polarization of the *analyzer* and *polarizer* of a polariscope equipped with *ordinary* Nicol prisms adjusted

for total extinction, AC being at right angles to EG . If a Jellet-Cornu prism is substituted for the Nicol prism polarizer, but placed in the same relative position as the latter, the plane of polarization of the polarizer will no longer be represented by the line EG , but can be by the broken line $DEE'D'$, if DE and $E'D'$ represent the respective positions of the planes of each half of the prism. In the position of the polarizer assumed, these planes make equal angles, DEA and $E'E'A$, with the plane of the analyzer AC .

Consequently, as these angles are also less than a right angle, the optical field defined by the circle which represents the diaphragm opening will appear evenly but faintly illuminated.

If the analyzer is rotated, its plane of polarization AC will approach a right angle with one of the polarizing planes DE or $E'D'$, and a shadow will appear in the corresponding half of the field. Thus there is only one position of the analyzer, within 180° , where both halves of the field appear evenly illuminated, and from which position the slightest rotation of the analyzer gives a shadow in one half of the field or the other. This is the true end point. It is true that the intermediate positions at 90° give a (thought) evenly illuminated field, but no shadows appear on slightly rotating the analyzer, as is evident from a study of the diagram.

The Duboscq rotatometer is an accurate and sensitive instrument, and can be used with any kind of homogeneous light. Formerly it was much used in France. The diagram also shows that, the nearer the angle of the tilting of the planes of polarization of the two halves of the prism to 180° , the more sensitive is the polariscope to small angles

of rotation; but, on the other hand, the field is darker at the end point. This indicates the most serious disadvantage of this type of polariscope, as it is impossible to make one instrument that will be applicable for universal laboratory measurements. If the polariscope has a prism giving sufficient precision for scientific work, it will not pass light enough at the end point for polarizing the dark-colored solutions often met with in commercial practice, molasses for instance.

Laurent Polariscope. — This need for a half-shade polariscope, having an end-point device by which the angle of the polarizing planes of the two halves of the field could be varied to suit the requirements of the work, was met in a most ingenious and satisfactory manner by Laurent in 1877.

The Laurent polariscope has the ordinary Nicol prisms for polarizer and analyzer, mounted in the usual way, except that the polarizer is so arranged that it can be rocked or rotated on its long axis through a small angle. The characteristic end-point device is a thin plate of quartz cut parallel to the optic axis of the crystal. A section so cut is doubly refractive, dividing a light beam entering normal to its surface into two component beams with vibration planes respectively perpendicular and parallel to the optic axis. The thickness of the section is such that, when sodium light is used, the component ray vibrating at right angles to the optic axis, on emerging, has its vibrations *accelerated*¹ half a wave length in its passage through the quartz. This

¹ The undulatory theory shows that the difference in refraction of the two polarized rays is the result of a difference in speed of transmission of the light waves, the less refracted ray being transmitted more rapidly.

quartz plate covers one half of the circular opening of a diaphragm which defines the optical field of the instrument, and through which the light passes from polarizer to analyzer. Therefore the quartz intercepts these rays in one half of the field.

The following diagram will assist the explanation: Let AB represent the vibration plane as well as the amplitude of vibration of the light from the *polarizer* which makes a small angle BAC with the

optic axis of the quartz plate, this axis being represented for convenience as parallel to the edge AC of the quartz plate bisecting the circle representing the diaphragm opening. When the light from the polarizer reaches the quartz, it is resolved into two components AC and AF , parallel and perpendicular to the

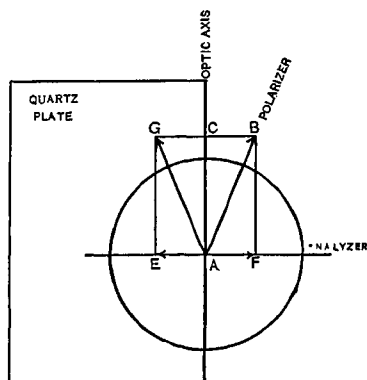

FIG. 6.

optic axis. The light of the component AF travels faster through the quartz than that of the component AC vibrating parallel to the axis, and, having gained on AC half a wave length, is at time of *emergence* from the quartz in just the *opposite phase* of vibration, relative to AC , to its original phase on *entering* the quartz. Consequently, this emerging component can be represented by the line AE equal to AF , but opposite in direction. By means of the parallelogram $AEGC$ it can be shown that the components AE and AC can be compounded into the resultant AG , as

if the light had come from a polarizer having its vibration plane inclined to the optic axis of the quartz at an angle GAC equal and symmetrical to the angle BAC actually made by the plane of the polarizer with the optic axis. So too the angles made by these planes with that of the *analyzer* are equal and symmetrical, when it is adjusted so that its vibration plane is perpendicular to the optic axis of the quartz, and hence the intensity of the light in both halves of the field is the same, the absorption and reflection caused by the quartz being negligible. Thus, the polarizer and the quartz plate together give the effect of a Jellet-Cornu prism, the planes of which are tilted to each other in each half of the field by a small angle; but have the valuable advantage that this angle can be *varied* at will by means of the rocking polarizer without disturbing the end-point adjustment of the analyzer, since the angles made by the vibration planes of the light in each half of the field with the analyzer plane always remain *equal* and *symmetrical* whatever their magnitude. In all other respects, the explanation of the light effects of the Jellet-Cornu prism polariscope applies to the Laurent instrument, so need not be enlarged upon here.

The Laurent polariscope is the one most generally used in direct laboratory measurements of optical rotation, and is the standard instrument used by the French government in testing sugars. Its use is obviously restricted to sodium light. The average error of measurement is stated by Landolt to be .2 per cent, due to mechanical imperfections inseparable from its construction. First-class French instruments certainly show agreement within an error considerably less than .2 per cent.

Lippich Polariscope — The Lippich polariscope, which is specially made for most precise measurements of optical rotation, uses a small Nicol for its shadow device, which is placed between the polarizer and the analyzer, close to the former, and covers half of the field, being mounted in an analogous manner to the Laurent quartz plate. The polarizer is mounted so that its plane of polarization makes a slight angle with that of the small Nicol, which latter is known as the "half prism." This angle can be varied at will by a device which permits the polarizer to be moved axially, an index showing the exact position of its plane of polarization relative to that of the half prism.

This instrument is said to be free from the errors believed to be inherent in the construction of the Laurent polariscope, and can be used to measure rotations of homogeneous light of any wave length. It has the disadvantage that the angle of the shadow device cannot be changed without altering the end-point adjustment of the analyzer. The Lippich polariscope is often constructed with great elaboration and nicety of adjustment, and is capable of measurements to $.001''$ with a mean error, according to Landolt, of $15''$ or about $.004''$. By means of a double prism end-point device, the field can be divided into three parts. It is estimated that the eye can distinguish the shadow change in a triple-field instrument with twice the precision, or to $8''$. These very precise instruments are used only in the most exact physical measurements.¹ In ordinary laboratory work polariscopes are used which

¹ For complete descriptions of these polariscopes, see Landolt's "Das optische Drehungsvermögen." See also my remarks on triple-shade saccharimeters.

measure to i' , or, with the more modern decimal scale, $.01^\circ$.

In using the Lippich polariscope it is necessary that the condensing lenses for illuminating the field be adjusted with the greatest care to insure even illumination without surface reflections. The instrument also seems to be much more sensitive to extraneous light than is the Laurent polariscope.

Wild Polariscope (*"Polaristrobometer"*). — The Wild polaristrobometer, invented in 1864, has for its end-point device a "Savart polariscope," which consists of two calc-spar plates cut at 45° to the optical axis of the crystal and placed with their vibration planes at right angles to each other¹ and at 45° to that of the analyzer, which is fixed, the polarizer being the rotating prism. The effect of this combination is to produce "interference bands" or black horizontal stripes in the field when homogeneous light is used. These bands disappear in the centre of the field at points 90° apart in the rotation of the polarizer. The exact point of disappearance of these bands, as shown by a blank space symmetrically placed relative to two cross hairs in the field, is taken as the end point. The displacement of this blank spot in the field is very marked for a slight rotation of the polarizer.

As it is the polarizer that rotates, its rotation is in the reverse sense to the rotation of the plane of polarization by the optically active substance; that is, dextrorotatory substances, for instance, have their rotatory effects measured by a corresponding rotation of the polarizer to the left.

¹ Wild, "Ueber ein neues Polaristrobometer," Berne, 1865.

The Wollaston method has not been popular in the United States, owing to the unusual end point and the excessive use of manipulation. It is, however, for a practical laboratory, sensitive and precise enough for most laboratory measurements.

THE SACCHARIMETER

General Principles.—As the value of the polariscope for the determination of sugar (sucrose) had quick recognition in commercial work, instruments were soon specially designed to give the sugar content of industrial products by a simpler, more direct way than by the use of the ordinary laboratory polariscope. Such instruments, known as “saccharimeters,” have scales graduated in divisions expressing per cents of sugar instead of angular degrees, and the manipulation of testing is so conducted that the saccharimeter gives a direct reading of the sugar per cent of the sample without calculation.

The theory of the graduation of a saccharimeter is very simple. As the optical rotation is directly proportional to the concentration of the optically active solution and the tube-length, it is clear that if the weight of sugar sample taken for polarization, the volume of aqueous solution in which this weight of sample is dissolved, and the tube-length are constants, the sole variable effect on the rotation (leaving out of consideration the slight influence of temperature and concentration on the specific rotation) will be caused by the difference in the amount of sugar in the sample. Further, if the constant weight of sample taken for polarization is that weight of pure sugar which will give a reading of 100 divisions of the saccharimeter scale, the reading

when this weight of *any* sample of sugar is polarized will directly express the per cent of sugar in the sample. This weight is known as the "normal weight" of the saccharimeter.

It is necessarily assumed that no other optically active substance than sugar (sucrose) is present in the sample.

The most convenient values for tube-length and volume, universally adopted in saccharimetry, are 2 decimeters and 100 cubic centimeters. The standard commercial saccharimeter in this country and abroad, except in France, has a normal weight of 26.048 grams.

Originally, a different standard of graduation was used, and it still prevails in the rotary saccharimeters, which were the earliest type. On this account it may be profitable to show the origin of these standards of graduation. The *angular-degree* graduation is not suited for a saccharimeter scale, as simple calculation will show. By the formula, $w = \frac{\alpha z^2}{a l}$, derived from the fundamental equation

expressing optical rotation, making $a:100$, $l:2$, $z:100$, and taking $[\alpha]_D$ of sucrose in aqueous solution as 66.50:

$$w = \frac{100 \times 100}{66.5 \times 2} = 75.2 \text{ grams of sugar as the normal weight}$$

for the angular-degree scale. This is an impracticable amount of sugar to dissolve in 100 cubic centimeters of water at ordinary laboratory temperature. The saccharimeter graduation consequently requiring a smaller rotation value for its 100 point, a convenient constant was found in the specific rotation of quartz, that is, that caused on the D ray by a millimeter section of right-rotating quartz cut perpendicular to its optic axis. This value as originally

determined was 21.667° at 17.5° C. for light obtained by vaporizing sodium chloride in a Bunsen burner and using as a ray filter a section of potassium bichromate crystal. The normal weight of sugar found by the equation given above for the commercial standard of volume and tube-length is 16.29 grams.

When the sugar is dissolved in 100 "reputed" or Mohr cubic centimeters on a temperature standard of 17.5° C., as is the custom in commercial work, the normal weight is 16.32, owing to the volume of the Mohr flask being .23 per cent greater than the "true" cubic centimeter flask.¹ This will be discussed later.

The Laurent and Duboscq rotatory polariscopes are provided with saccharimetric scales of this graduation, in addition to their angular degree scales. The Wild polariscope

¹ Much misapprehension prevails as to the exact value of the normal weight of the Laurent saccharimeter. This is partly due to the existence of instruments standardized for a normal weight of 16.19 grams, and partly to the fact that the specific rotation of quartz has been re-determined by instruments using light of a different wave length than that used for the ordinary laboratory type of Laurent polariscope.

No light obtained from a sodium flame by the ordinary methods is "optically pure," of one definite wave length, but contains light of many wave lengths differing by but small values from that of the two *D* rays, which are themselves obviously of two different wave lengths.

Such light acts like absolutely homogeneous light of a wave length corresponding to a ray which represents the resultant intensity of these diverse rays, its wave length being called by the Germans the "*Schwerpunkt*" or "centre of gravity" of the light. The "optical centre of gravity" of the light used in the later measurements of quartz differed from that used in the Laurent polariscope, and apparently has given rotations about .2 per cent larger.

Evidently, a normal weight of sugar calculated on the rotation value of a millimeter section of quartz would be higher also in the same ratio.

As a matter of fact, the normal weight of the standard Laurent saccharimeter has been a fixed value for years, being actually that weight of sugar which, dissolved under standard conditions of concentration and tube-length,

has an additional achromaticity scale divided into spaces of 1000, each of which corresponds to 100 divisions of angle dissolved in 100 cubic centimeters.

Quartz wedge Saccharimeters. General Principles. In commercial work, where many rapid polarizations have to be made, the ordinary light is inconvenient to maintain and trying to the eyeight. At the same time, owing to the unequal rotation dispersion of the rays of different wave length, it is impossible to use the saccharimeter with rotating analyzer, and measure the rotation of the polarized light directly, if the light used is white or of a compound nature. This has been explained in the chapter on Fundamental Principles.

The problem of devising a saccharimeter for use with ordinary lamp or day light was solved most ingeniously by the quartz wedge compensator, invented in 1848 by Soleil, who found that the rotatory effect of sugar solutions could be exactly neutralized by a plate of left rotating quartz of appropriate thickness. The *kind of* light has no influence, as, owing to the fact that the dispersive power of quartz and sugar in water solution are practically the same (that is, the planes of polarized light of different wave lengths are turned in the same proportion by sugar solutions and quartz), the plane of polarization of *each* ray is brought

gives a rotation of 21.46° (21.667) to the axis of a solution of 100 parts of sugar filtered through a section of polarizing calcareous crystal. Whether this value has been accepted as the specific rotation of sucrose, or not, is immaterial for accuracy in an instrument, or even for ordinary measurements, if, in the latter case, the wave length value of the optical centre of the light is known. Apparently, there have been no wave length determinations of the optical centre of light as actually used by the Laurent saccharimeter in sugar testing.

The earlier saccharimeters of Dubouche used a normal weight of 47.15 grams

back to the same angular position which it had before being rotated by the sugar solution.¹

Hence, for any concentration of solution there is a corresponding thickness of left-rotating quartz which will just neutralize (compensate for) the rotatory effect of the sugar. The Soleil quartz-wedge compensator is a device for introducing at will what is in effect a section of left-rotating quartz of the desired thickness between the polarizer and analyzer.

The diagram, shown as a plan, will explain the compensator and its working. *AB* represents the line of transmission of the light through

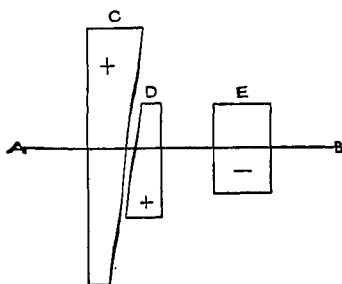

FIG. 7.

the instrument along its axis, the analyzer being at *A* and the polarizer at *B*. *C* and *D* are two wedges of right-rotating quartz with parallel sides which are movable by being slid past each other in a direction at right angles to the axis of the instrument (*AB*). Together, these two wedges make a section with parallel sides, at right angles to *AB*, of a thickness which can be varied at will by moving one or both of the wedges.

E is a section of left-rotating quartz. When the combined thickness of *C* and *D* equals that of *E*, the opposite rotating effects of the two wedges and the section *E* balance, and the scale of the saccharimeter attached to the wedges reads zero. If, however, a tube of sugar solution is placed in the instrument between the polarizer and the

¹ See table of the comparative rotatory dispersion of quartz and sugar solution in Landolt (p. 133).

compensating device, it will be necessary to increase the thickness of the right rotating section made by the wedges by sliding them by each other outward till the left-rotatory effect of the section Z balances the combined effect of C , D , and the sugar solution. If the 100 point of the wedge scale shows the position of the wedges to compensate for the rotary effect of the normal weight of pure sugar polarized under standard conditions, then the percentage purity of any sample will be given by the scale reading if the usual procedure is followed.

The Soleil Duboscq Saccharimeter—About 1850, Duboscq was the first to make a practical quartz-wedge saccharimeter for commercial testing. The Soleil Duboscq saccharimeter was the transition tint quartz plate already described for its endpoint device, and practically eliminates the disturbing effects of colored solutions by what is known as the "sensitive tint producer," an attachment for producing light of the color desired to overcome the disturbing tint of any highly colored solution by combination or interference. It consists merely of a third Nicol prism, ranged to be rotated, and placed between the eyepiece and the analyzer. Between these two prisms is a section of quartz cut perpendicular to its optic axis. By rotating this tint-producing prism, any tint desired can be made in the field. This effect is produced in the passage of the light from the analyzer of the saccharimeter, which latter in this case acts as a polarizer relative to the prism of the tint producer, and is in accord with principles already explained in describing the sensitive plate in a previous chapter. Obviously the tint device must be adjusted for each colored solution polarized.

The tint is so chosen as to make a background for showing to best advantage the color change in the transition-tint plate, so that very delicate variations in color in either half of the field can be noted with precision. The tint device in no way affects the measurement of the sugar solution, since this obviously is made through adjustment of the position of the quartz wedges compensating for rotations which take place between the two fixed Nicols, the polarizer and analyzer of the saccharimeter.

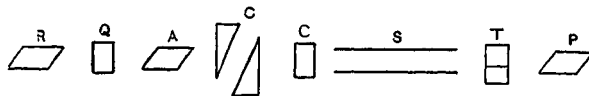

FIG. 8.—DIAGRAM OF OPTICAL PARTS OF SOLEIL-DUBOSCQ SACCHARIMETER (eyepiece and condenser lenses not shown).

- | | |
|---|---|
| <p>A. Analyzer.
P. Polarizer.
CC. Quartz compensator.
T. Transition-tint plate.</p> | <p>S. Position of tube of sugar solution.
RQ. Rotating Nicol and quartz in eyepiece, for producing sensitive tints.</p> |
|---|---|

The normal weight of the Soleil-Duboscq saccharimeter is based on the rotation value of the millimeter section of quartz, but is usually given as 16.35 grams instead of 16.32.

The Soleil-Ventzke-Scheibler Saccharimeter.—The normal weight of 16.3 grams of sugar does not give a solution of sufficient concentration to show variations in tint, in measurements on the Duboscq-Soleil saccharimeter, for the ordinary observer to distinguish with precision differences corresponding to .1 per cent of sugar in the sample, and as this was demanded by modern commercial requirements, an improved instrument was designed by Scheibler, which used the graduation of Ventzke, the 100 point being at the position of compensation for a sugar solution of the density

of 1.1000 at 17.5° referred to water at 17.5°. This standard has been more conveniently expressed as equivalent to 26.048 grams of sugar, weighed in air, and made up to a solution of 100 Mohr cubic centimeters at 17.5°, and gives .026 grams for producing a change of .1 per cent of the scale, instead of .016 of the old standard, quite sufficient to make a distinguishable change in tint at the end point. Scheibler also improved the quartz-wedge saccharimeter in many details of design, greatly increasing its practical efficiency.

While the modern transition-tint saccharimeter, the Soleil-Ventzke-Scheibler, as it is formally designated, is a precise instrument in the hands of trained observers, and still much used, it has been largely replaced in the past few years by the shadow saccharimeter; for, as already noted, any transition-tint instrument is useless to the color-blind, and requires much more practice to read with precision.

The Schmidt and Hänsch Half-shade Saccharimeter.— This differs from the modern transition-tint instrument in using the Jellet-Cornu prism for an end-point device. Consequently, the observer determines the end point by an equality of shade instead of tint. This type represents the best modern saccharimeter. With such an instrument, using ordinary artificial light, the intensity being much greater than the sodium flame, the objections to the Jellet-Cornu prism, mentioned in describing the Duboscq (rotatory) polariscope, do not apply, as the prism can be cut to give sufficient precision without impairing the illumination too greatly.¹

¹ Some of the most recent instruments of Schmidt and Hänsch use the Lippich double-shade polarizer and an improved arrangement of illuminating

The Triple-shade Saccharimeter. The triple-shade device of the Lippich polariscope, recently applied to quartz-wedge saccharimeters, is becoming popular as it gives according to some authorities a more precise end point (to .03 per cent), but it considerably complicates the instrument, and is liable to get out of adjustment. It is doubtful whether usual conditions permit this greater precision to be of avail. Moreover, an expert can easily read the half-shade type to .03 per cent.¹

Peters Saccharimeter. The Peters instrument with the Lippich shade device differs in the main from the Schmidt and Hänsch² in the mounting, which is designed for great stability and rigidity. In the latest instruments the wedges are inclosed in a dust-proof box which also mitigates the effect of sudden temperature variations. The pinion for moving the wedges is lengthened so that the observer can move it with his hand resting on the table, a small detail which greatly adds to the comfort of manipulation.

Instead of the ivory scales used in the earlier instruments, both the Schmidt and the Peters saccharimeters are now fitted with scales of an alloy known as "nickel-in,"

lens as recommended by Lambert ("Das optische Drehungsvermögen," p. 144). These instruments have an improved form of compensator devised by Matthes (*Zeits. Instrum.*, 20, 82), consisting of two quartz wedges corresponding to *C* and *D* of Fig. 7, but of *opposite* rotations. On the shorter focal wedge (*D*), is cemented a prism of glass, of the same dispersion as quartz, which serves to keep the rays in alignment with the optical axis of the instrument. The advantages gained are less loss of light by absorption and a saving of one quartz section, which is a consideration of some importance, as there is hardly an adequate supply of quartz sufficiently optically pure to meet the demand for saccharimeters.

¹ By "per cent" is meant the scale division corresponding to a per cent.

² Schmidt and Hänsch have adapted this form of mounting in some of their newer saccharimeters.

which is unaffected by moisture and so little by temperature as to make any change in the divisions negligible.¹

The Double-wedge Saccharimeter. — The compensation system of these saccharimeters has both quartz sections made variable by sliding wedge devices. The wedges are arranged as in the diagram.

A and *B* are right-rotating quartz wedges, corresponding to those in the ordinary single-wedge instrument; *C* and *D* are the left-rotating quartz wedges. *B* and *C* are movable,

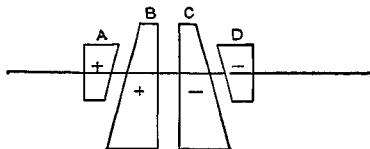

FIG. 9.

the first known as the "working wedge," the second as the "control wedge." Both pairs of wedges are provided with scales of equal saccharimetric value.

In ordinary use of the saccharimeter, the control wedge is set at zero, and the working wedge is used in the ordinary manner for making saccharimetric measurements. On removing the tube of sugar solution, the *control* wedge can be used to check the readings, because if compensation is now made by moving this wedge, — without disturbing the working wedge from the setting for the reading first taken, — both wedges will give equal readings. So, too, when no rotating solution is in the instrument, the end point will be obtained when both wedges have the

¹ Fric uses a milk-glass scale illuminator for making the metal graduations clearer. Some recent instruments have the graduations engraved on the quartz of the compensator itself.

same readings at any point of the scale. The double-wedge compensation, consequently, enables the readings of the saccharimeter to be checked throughout the scale, as well as giving a check on the observation itself.

The greater complication and expense of the double-wedge saccharimeter prevents its general use.

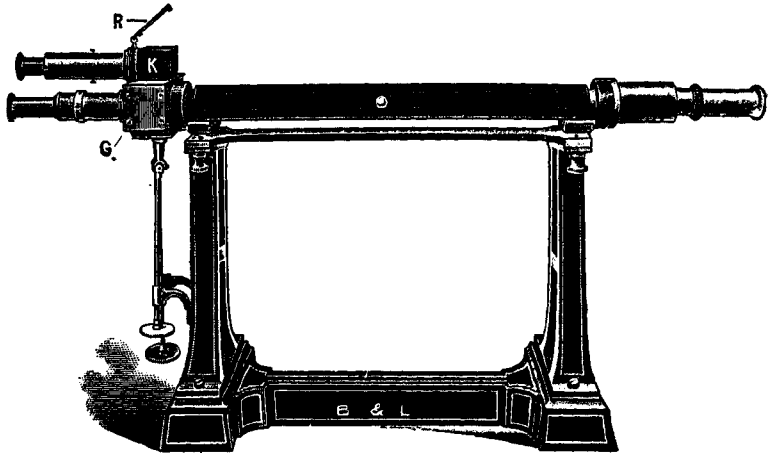

FIG. 10. — RECENT TYPE OF PETERS DOUBLE-WEDGE HALF-SHADE SACCHARIMETER.

RR. Reflecting device for illuminating scale.

G. Box inclosing wedge compensator.

ACCURACY OF SACCHARIMETER MEASUREMENTS

Weight. — Taking the limit of error of commercial laboratory measurements as .1 per cent, it is clear that, as no saccharimeter in general use has a normal weight of less than 16 grams, weighings to .005 gram are certainly sufficiently precise. The most appropriate balance for weighing sugar samples is a quickly working balance of the necessary sensitiveness only. Indeed, the use of an analytical balance of high precision often leads to *more inaccurate* readings, as many commercial samples contain so much moisture that the loss by evaporation is considerable if the weighing is prolonged.

Tube-length. — An accuracy of length to .1 millimeter is obviously sufficient for all ordinary laboratory measurements where the 2-decimeter tube is used. Tubes of standard makes rarely show errors of length as great as this.

Volume. — The cubic centimeter, according to the absolute metric standard, is defined with sufficient exactness as equivalent to the *volume occupied by 1 gram of water weighed in vacuò at the temperature of maximum density, 4° C.*¹ Some saccharimeters are graduated for a normal weight of 26.048 grams of sugar dissolved in 100 true (absolute) cubic centimeters. Almost universally the stand-

¹ The term "milliliter" has been applied to this unit to distinguish it from the cube whose edge is 1 centimeter.

ard of volume used in saccharimeter graduation is the cubic centimeter as modified by *Molur*, which in this case can be defined as the *volume occupied by 1 gram of water weighed in air with brass weights at a temperature of 17.5° C.* As the 100-cubic-centimeter Mohr flask holds 100.234 true cubic centimeters, saccharimeters graduated by the different standards vary in actual *rotation* magnitudes of the scale divisions by .234 per cent.

This, if not understood, will make confusion when saccharimeters of the two different graduations are compared with reference to the actual magnitude of the divisions by standard quartz plates, or, if the appropriate measuring flasks are not used, in "polarizing" samples.

Evidently, flasks should be correctly graduated within .05 cubic centimeter.

Errors of Instrument. Eccentricity. — In rotatory polariscopes, as in all instruments giving angular measurements, errors are due to the axis of the rotating part of the apparatus not being exactly coincident with the centre of the circle on which the scale is graduated.

This error can be eliminated in instruments having scales extending over the whole circle of rotation in the usual way, by measuring the angle of rotation in opposite quadrants, that is, taking the mean of a and $a + 180^\circ$, for it will be remembered that the end-point phenomena repeat themselves at points 180° distant.

The "eccentricity" of a polariscope of good make is rarely more than the limit of error of the readings, but occasionally the scale disks of polariscopes become bent by some accident so that errors of more than $4'$ may be due to this cause.

Errors of Quartz-wedge Saccharimeters.—The correctness of the saccharimetric scale can be established at a few points by comparisons with standard quartz plates of known rotation.¹ A much more thorough method of calibration, which permits all points of the scale to be standardized, is by use of the "control tube." The control tube is telescoping and is adjustable to variations of length through a range of about 100 millimeters, its exact length at any position of adjustment being measured by a scale reading to .1 millimeter. As the readings of the saccharimeter are directly proportional to the tube-length, it is possible by means of a few sugar solutions of appropriate strength to verify any reading.

Since the reading (R) gives the per cent (P) of sugar when $l = 2$, $v = 100$, and w' is the normal weight (N), the equation for the per cent of sugar when any length of tube is used is $P = R \frac{2}{l}$, and the reading for any length of tube will be expressed by $R = P \frac{l}{2}$. If the normal weight of chemically pure sugar is used, $R = \frac{100 l}{2}$. Knowledge of the concentration of the sugar solution used is not, however, necessary, if the solution is concentrated enough so that a length (L) can be found which will by experiment for the solution used give a reading of 100 on the saccharimetric scale, the correctness of this point having been previously verified by a standard quartz plate, since, obvi-

¹ The values stamped on the plate mountings are not always reliable. Quartz plates can be exactly standardized by sending them to the United States Bureau of Standards, Washington, D.C., which does this work for a small fee.

ously, any reading (R) will be given when the tube is of a length $\frac{RL}{100}$, or the reading at any tube-length (l) will be expressed by the following equation, $R = \frac{100 l}{L}$. Thus, the actual reading at any position of the wedge can be compared with that calculated by the formula.

Zero Error.—In common with most measurements, polariscope readings must be corrected for “zero error,” which is the difference in scale divisions between the scale reading at the observed end point and the zero of the scale, when observations are taken with no optically active substance in the instrument.

Personal Errors of Observer.—In all exact measurements, the influence of the personal errors of the observer are diminished as much as possible by averaging the results of several readings. In comparing the work of two observers, however, it must not be forgotten that considerable differences may be shown if the readings of each are uncorrected by the zero error obtained by the observer himself. The results, while differing appreciably in the actual readings, should, on applying the *zero corrections*, be found to be concordant. Each observer unconsciously uses a slightly different end point, which does not affect the accuracy of his observations, provided the *same* end point is recognized at zero and at the position of rotation measured.

Distortion of Cover Glasses of Polariscope Tubes.—If the caps of polariscope tubes are screwed on too tightly, so as to produce a strain in the glass, the unequal distribution of density may cause a rotating affect on the light rays and so make error. With the earlier forms of tubes, this was

not unusual; but with the modern types, with fine-threaded screws and soft rubber washers back of the glasses, error from this cause is rare.

Laurent has devised tube caps with bayonet catch and a light spring which makes it impossible to exert undue pressure. Landolt accomplished the same object by caps which are held on by the friction of ground joints. The Laurent type is hard to keep clean and free from corrosion, while the Landolt tubes are more liable to leakage than the screw cap, which is the most practical form and almost universally used.

Variations from Standard Temperature. — Saccharimeters are graduated to read correctly at 17.5°C ., it being assumed that the solution is made up at the standard temperature. Almost always the temperature of modern laboratories is higher than this. The effect of this higher temperature on the reading is a complicated one. The slight increase in the reading, rarely amounting to more than a few hundredths of a division, due to the linear expansion of the tube, is partially compensated for by the slight increase in volume of the flask caused by the expansion of the glass.

The greatest influence caused by temperature change is on the specific rotation of the sugar, which decreases with temperature increase. Andrews has found that when a sugar solution is made up to the normal concentration and polarized at a temperature greater than 17.5°C ., the readings are too low, in the case of a rotatory saccharimeter, by .00018 of their value for every degree of temperature above the standard.

This assumes that all apparatus, flask, tube, and saccharimeter, as well as the water used in making up the

solution, are at the same temperature. In the case of the quartz-wedge saccharimeter, a greater error is introduced, owing to the increase in specific rotation of the quartz wedges by temperature increase.¹ Andrews found that the correction for quartz-wedge saccharimeters was .00030 per degree above standard temperature. Wiley² has confirmed this latter correction more recently by an investigation covering temperatures from 0° to 40° C. Investigators of the United States Coast and Geodetic Survey had arrived at practically the same correction value as early as 1890. The coefficient calculated from Schönrock's recent values is somewhat higher.

It must be understood clearly that correction for temperature can only be made when the temperature conditions are *constant*. Especially in the case of quartz-wedge saccharimeters, such corrections may be *quite fallacious* if there is considerable temperature variation during the day, as the quartz wedges, which are the parts of the instrument most affected, assume the outside temperature very slowly, owing to their thickness and poor conductivity.³ Constant temperature conditions are vital for accurate saccharimetric work.

Although these values for temperature correction seem well established by careful investigation, they are disputed by some, and have not yet been applied in commercial testing.

¹ *Technology Quarterly*, 1889, p. 367. *Id.*, p. 373.

² *J. Am. Chem. Soc.*, 1899, p. 568.

³ Variations of considerable magnitude occur in polariscope readings caused by temperature changes apparently due to the displacement of the optical parts by the expansion or contraction of the metal in the mounting of the instrument. These manifest themselves in the *zero error*, which should be frequently taken during temperature changes.

Quartz plates, when properly mounted, always give constant readings on the quartz-wedge saccharimeter at all ordinary temperatures, *provided that the quartz-wedge compensator system and the plate are at the same temperature*. Obviously, the temperature changes affecting the rotation will be alike in the plate and compensator. On this account, quartz plates are the most convenient for standardizing this type of saccharimeter, as control-tube standardization requires most careful temperature correction if the sugar solutions are not made up and polarized at the standard temperature.¹

Most sugar chemists have adopted the recommendations of the International Commission for Uniform Methods in Sugar Analysis, and agreed to make all polarizations at 20°.

In the case of instruments measuring the angle of rotation of the quartz plate directly (rotatory polariscopes), the coefficient of increase of rotation for every centigrade degree of temperature above standard is .000143.

¹ Commercial saccharimeters used for valuing raw sugars and molasses are usually standardized by means of carefully corrected quartz plates of values approximating within a few per cent the polarization of the sugar to be tested. The reading of the plate given by the instrument is carefully corrected to the true value of the plate, and this correction applied to the polarization of the sample, the zero error being ignored. By this method of correction, the difference in actual magnitude of the scale divisions of instruments graduated in true or Mohr cubic centimeters is negligible, provided the readings of the standard quartz and the sample polarized do not differ more than 4 or 5 per cent, for in that interval a variation of less than .3 per cent in, say, 5 divisions would make an error of only .015, which is obviously well within the error of observation. Even a sugar polarization varying 20 divisions from the standard plate value, if the saccharimeter were standardized to that value independently of its zero error, would be correct within .06; if, for instance, a Mohr cubic centimeter flask were used instead of a true cubic centimeter flask in making up the solution.

The scale of graduation for quartz-wedge saccharimeters (almost universal throughout the commercial sugar world) being that for 26.048 grams of sugar dissolved in 100 *Mohr* cubic centimeters (the original Ventzke scale), Herzfeld has calculated the normal weight for this original and standard scale, when the sugar is made up to 100 *true* cubic centimeters ("milliliters") and polarized at the more convenient temperature of 20°, to be 26.01 grams.

This calculation can be expressed by the following equation :

$$N = \frac{100}{100.234} 26.048 \left[1 + \frac{(20 - 17.5).000143}{(1 - (20 - 17.5).000217)} \right]$$

The part in the brackets represents the increase in rotatory power of the quartz in the compensator of the saccharimeter due to the difference in temperature between 17.5° and 20°, necessitating a proportional increase in the normal weight. The last member in the parenthesis shows the decrease in rotatory power of the sugar caused by the higher temperature.¹

The International Commission has decided to use the even value 26.00. The difference of .01 gram, amounting to .04 per cent, may be of no consequence in ordinary commercial work, but is hardly in accord with the recommendation of the Commission to weigh all samples to .001 gram, or to .004 per cent.

The official saccharimetric standard adopted by the United States Customs² is 26.048 grams, weighed in

¹ *Zeitschr. Analyt. Chem.* 38, A. V. u. E. 22.

² United States Treasury Document No. 2113, Division of Customs, p. 16.

vacuo, and dissolved in 100 true cubic centimeters, all solutions being made and polarized at 17.5° .

Apparently all Schmidt and Hänsch saccharimeters sent to the United States subsequently to about 1892, and having a serial number above 3200, are graduated for 26.048 grams of sugar in 100 true cubic centimeters to conform to this standard. (See footnote No. 2.) The Peters saccharimeters examined by the author have been standardized on the original Ventzke scale.

Special errors peculiar to commercial saccharimetry will be discussed under the descriptions of commercial sugar polarizations.

GENERAL NOTES ON APPARATUS AND LABORATORY MANIPULATION

Installation. — The laboratory for polariscopic testing should be kept at as nearly a constant temperature as possible, preferably 20°, and therefore be well ventilated, and of sufficient size not to be affected by the heat of lamps. Polariscopes should be so installed that the observer is screened from outside light.

This is done sometimes by placing the polariscopes in a separate darkened room, the light passing into the instrument through a hole in a partition from a lamp outside, appropriate means of illumination of scales being by reflectors or small electric or gas lights. The more convenient method is to place the apparatus in a large, well-ventilated hood, so located in a shaded part of the room that the direct light cannot enter, the necessary illumination being arranged as described.

The polariscopes should be screened from the direct heat of the lamps by glass plates or, better, absorption cells filled with water.

Care of Instruments. — Like many instruments of precision, polariscopes are extremely sensitive to derangement from careless handling. Polariscopes should be disturbed as little as possible beyond the usual manipulation of testing. Nicol prisms, from the nature of their material, are peculiarly liable to injury. Calc-spar, being

much softer than glass, is easily scratched by careless handling or cleaning. Its peculiar crystallization makes it liable to split from rapid changes of temperature, as in overheating by placing the instrument too close to the lamp. Calc-spar is easily corroded by acids caused by fermentation of sugar solutions carelessly spilled in the instrument. With proper care, polarizing apparatus will last a lifetime. As the accuracy of the sugar chemist's work is dependent on the precision of the instrument, daily practice in such care as will insure this precision is obviously a necessary part of the knowledge and duties required of every worker in a sugar laboratory.

Handle the instrument with clean hands. See that the flame of the lamp is about 200 millimeters (the length of an ordinary polariscope tube) from the end of the instrument. This avoids overheating, which not only endangers the prisms, but throws the instrument out of adjustment. With most types, it also insures an evenly illuminated field of maximum brightness, as the foci of the condensing lenses are adjusted for this distance. Only when *absolutely* necessary, clean lenses, quartz wedges, and cover glasses with perfectly clean filter paper or linen cloth, never with silk or chamois, as the rough surfaces of these fabrics are liable to hold grit. Always rub *very lightly*. In cases where the edges cannot be reached, remove dirt very carefully with a clean, pointed stick of soft wood, as a toothpick.

Clean Nicol prisms with special care, and only when absolutely necessary. In the best instruments, Nicol prisms are protected by cover glasses where they would otherwise be exposed.

Polariscope Lamps. — Many forms of sodium-light lamps have been devised. Most of them use ordinary table salt, which is best adapted for the purpose, the other common salts of sodium not volatilizing so readily, and consequently giving less intense light. Sodium carbonate works reasonably well, but causticizes to a considerable extent, forming a corrosive liquid which drops down and fouls the apparatus. Sodium bromide is said to produce a more intense light than the chloride, but gives off bromine vapors which are liable to injure the polariscope. Landolt uses cylinders of salt which are fused on small forms made of nickel wire netting. Wiley has devised a clockwork lamp by which the salt is fed into a Bunsen flame from opposite sides by means of two slowly revolving wheels of platinum gauze which dip into dishes holding a salt solution. The author has preferred the ordinary type of lamp, which consists of a Bunsen burner so adjusted as to burn with as strong an air blast as possible, this being a requisite for any lamp giving intense light. The salt is exposed to the flame in a platinum or nickel gauze spoon, which is heated in the mantle just outside the luminous cone, — the hottest part of the flame. The intensely bright yellow sodium vapor is then carried by the blast well above the blue cone of the flame, the light of which latter should be cut out of the polariscope field by a diaphragm attached to the lamp. A mixture of table salt with sodium phosphate, as recommended by Dupont, fuses upon the gauze and does not decrepitate as salt does alone. A mixture of these powdered salts made into a paste with a little glycerine has been found very convenient for applying to the gauze with a small platinum spatula.

Quite recently the author has adopted a simple type of sodium lamp which has proved by far the most convenient and efficient. A shallow boat, made by folding a rectangular piece of platinum foil and welding together the ends by hammering at a red heat, is used to hold the salt. The boat is of such shape as to spread the flame of a Tirrill burner, which impinges against the polished platinum, after the manner of a batwing flame. The salt which is liquefied creeps up the sides of the boat, and is vaporized in the flame sheet, giving a very brilliant and steady light which lasts for fifteen minutes or more without renewing the salt.

The flame shoots off obliquely, thus exposing more light surface in the axis of vision. From time to time lumps of salt (which have been previously fused) are added till the boat is again filled with liquid.

The diagrams explain the apparatus, the exact adjustment of the position of the platinum boat being easily determined by experiment.

A more elaborate but somewhat more efficient boat for holding the salt is shown in Figure 12. A piece of platinum foil is folded double in such a way as to make a double-bottomed boat, the edges of the folded sheet making a narrow slit along one edge of the boat. The inner bottom is perforated. In this form the liquefied salt rises by its capil-

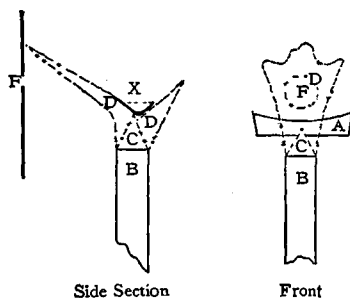

FIG. 11.

- A. Boat.
- B. Burner-tube.
- C. Blue flame cone.
- D. Yellow flame.
- E. Diaphragm-opening.

larity to the mouth of the slit and is taken by the strong blast of the lamp up into the flame in a brilliant sheet. Such an arrangement has given a constant light for an hour without replenishing.

The platinum boats must not be too large, or the mass of metal chills the flame and reduces the intensity of the light appreciably. It may be needless to add also that the burner must be working with as strong an air blast as possible.

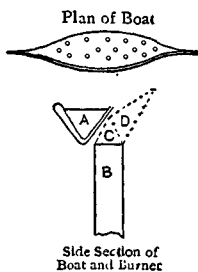

FIG. 12.

Most polariscopes are equipped with a plate of potassium bichromate crystal to filter out extraneous rays. Landolt uses an absorption cell filled with a weak solution of this salt, and a second

cell containing a solution of uranous sulphate.

For the quartz-wedge saccharimeter, any strong lamp-light serves. The Welsbach light is particularly good. Where gas cannot be had, Welsbach burners can be obtained which use vaporized kerosene on the type of the "Washington" light.¹ Acetylene and incandescent electric lights are often used. Schmidt and Hänsch have perfected an electric light which can be attached to their saccharimeters. This is of small size and, while giving light of great intensity, produces very little heat.

Balance. — For ordinary polariscope work, a quick-working balance with a capacity of 200 grams and sensitive to .005 gram is preferable to the more precise analytical type. It should be inclosed in a glass case. Such balances, known as "sugar balances," are made by all the leading

¹ Used by the writer in Porto Rico.

manufacturers. They are also best adapted for calibrating most volumetric apparatus. A "trip scale" with a capacity of 2 kilos and sensitive to .1 gram is indispensable for many of the laboratory operations incident to preparation of solutions and calibrating the larger volumetric apparatus; while, of course, many of the more delicate weighings of exact density determinations and other gravimetric measurements require a delicate analytical balance.

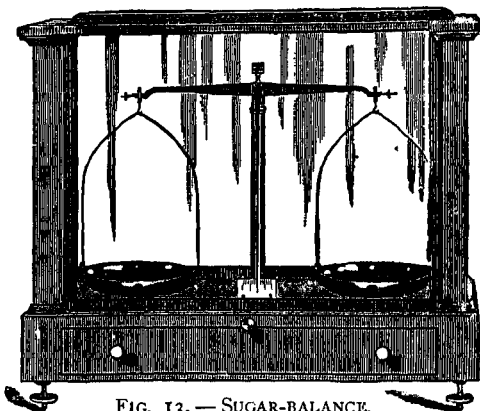

FIG. 13.—SUGAR-BALANCE.

Sugars and other non-corrosive substances are usually weighed out in nickel or German silver dishes provided with a lip for pouring.

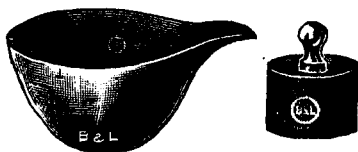

FIG. 14.—WEIGHING-DISH AND TARE WEIGHT.

These dishes are numbered and provided with a correspondingly numbered tare weight. The substance is either dissolved directly in the dish by rub-

bing the crystals under water, using a metallic pestle, or washed into the measuring flask, the former being the usual method.

In saccharimetric work, either the normal or half-normal

weight is taken, brass weights of this value being furnished with the saccharimeter. The half-normal weight is only used when the sample makes a dark solution not readily clarified, and consequently difficult to read in the polariscope, such as a low-grade molasses, for instance. [For Manipulation of Polariscope Tubes, see p. 91.]

Flasks. — The 100-cubic-centimeter flask is the one most conveniently used. Practically all commercial saccharimeters are graduated for solutions made up to 100 *Molir* cubic centimeters, the unit of which has already been defined as the volume occupied by 1 gram of water at a temperature of 17.5°, weighed in air with brass weights. Recently there has been a strong movement on foot among the chemists of all nations to use the true centimeter as the basis of measurement. [See p. 46.]

Special Laboratory Apparatus. — Short-stemmed funnels of a capacity of 75 to 100 cubic centimeters have been found most convenient for filtering solutions for polarizing. These funnels are placed directly on heavy glass cylinders for receiving the filtrate, thus obviating a separate filter stand. The cylinders have a lip for pouring, and, most conveniently, a capacity of 100 cubic centimeters. Watch glasses are used to cover the funnels to prevent evaporation during filtering.

Besides the ordinary 100-cubic-centimeter flasks, those with a double mark on the neck, one at 100, the other at 10 cubic centimeters, as well as similar ones marked at 50 and 55 cubic centimeters, are used in special operations, to be described later.

Clarifying reagents, such as basic lead acetate, are preferably stored in large bottles arranged with delivery tubes

for convenience in using. The delivery tube should be connected with a coarse burette, or, what is more clearly, a graduate used so that the volume of the reagent added is known with fair accuracy. This is important in some cases where corrections are to be made for errors caused by clarifying.

A similar tubulated bottle of large capacity should be provided for the water used in making up solutions which thus can be maintained at laboratory temperature. A convenient arrangement is to equip the bottle with two delivery tubes, one for quick delivery, the other a fine jet for filling flasks to mark.

Other apparatus, such as a muffle for ash determinations, drying ovens, etc., need not be considered here, as it differs in no wise from that used in general food chemistry.

Immediately after use, all glass apparatus, as well as polariscope tubes, should be washed in running water and placed on racks to dry. This insures a sufficient supply of clean and dry apparatus at all times.

Brix Spindles.—Brix spindles¹ are most conveniently made in the following sizes: 0-5, 5-10, 10-20, 20-30, or with a range of not over 10° for the higher concentrations. They should be equipped with thermometers, and not be too large for convenient use, not over 12 or 14 inches long. The graduations should be of sufficient size to permit of easily reading to .1°. If the expansion corrections for 17.5° are marked on the thermometer scales, they should be figured for the *middle* Brix reading; for instance, for a 10-20 hydrometer the expansion corrections should be for 15°.

¹ Described on p. 117.

A draining rack with holes for holding the spindles should be provided, or pockets made of copper gauze, which are very convenient.

Calibration of Flasks. — Weigh the thoroughly cleansed and dried flask to .005 gram. Weigh again when filled to the mark with freshly distilled water of known temperature. The volume of the flask, in Mohr cubic centimeters, can be computed from the following formula :

$$v = P \frac{d'}{d} [1 - .000025(t - 17.5)];$$

where v expresses the desired volume at 17.5°; P , the weight of water in grams which fills the flask to the graduation mark at the temperature t ; d' , the density of water at 17.5° C.; and d the density of the water at temperature of weighing. These density values are obtained from tables. That part of the equation which is inclosed in brackets expresses the correction on the volume caused by the expansion of the glass of the flask, and is small enough to be omitted for ordinary calibrations made at room temperatures.

Flasks for commercial saccharimetry are usually graduated by reading the lower edge of the meniscus of the water surface tangent to the upper edge of the graduation mark on the neck of the flask, when the whole of the meniscus is shaded. This is done by holding the flask up to the light with the mark on a level with the eye, or looking at the mark against a background, made by a piece of white paper, held in strong light a few inches back of the flask. Care must be taken to have the flask neck perpendicular if the flask is held in the hand while reading the

mark, as well, of course, to be sure that the neck above the water surface is perfectly dry. If there are adhering drops, they should be removed completely with a wisp of filter paper.

True cubic centimeter flasks, as has been stated already, are graduated on a unit which is the volume occupied by 1 gram of water weighed in vacuo at its maximum density (4°). The weight of the air displaced in the space taken by the water is only partially balanced by the air displacement of the weights in the other pan of the balance, as the volume of the latter is less than one eighth as large, owing to their greater density. In consequence the actual *mass* of the water weighed is expressed by a value somewhat more than .1 per cent greater than its *apparent weight in air*. It can be shown that the true mass of any given volume of water can be found from its weight in air with ordinary weights by the formula,

$$W = P + P\sigma\left(\frac{1}{\delta} - \frac{1}{\Delta}\right);$$

where W is the weight expressing the true mass; P , the weight actually found by weighing in air by the ordinary method; σ , the density of air, taken as .0012; δ , the density of water, taken as 1.00; and Δ , the density of the balance weights, taken as 8.4. With these values, which are approximate enough for flask calibration, the value of $\sigma\left(\frac{1}{\delta} - \frac{1}{\Delta}\right)$ is .00106.

Moreover, as the water weighed at any temperature other than 4° is less dense, its volume is greater than at the standard temperature.

Hence, the complete formula expressing the *volume* of a flask in true cubic centimeters at 20° when the water it contains is weighed in the ordinary manner at the temperature t , is

$$v = \frac{d_4}{d^t} (P + .00106 P') [1 - .000025(t - 20)];$$

where d_4 is the density of water at 4°, and d^t the density at the temperature it had when weighed.

The 100 *Mohr* cubic centimeter flask used in saccharimetry has a volume of 100.234 *true* cubic centimeters. The 100 *true* cubic centimeter flask contains 100.766 *Mohr* cubic centimeters.

Flasks should be numbered (conveniently, by marking on the neck with a diamond) and their calibrations recorded.

Observations. — Before taking readings see that the field and the scale are properly illuminated. The field should be as evenly and brightly lighted as possible at the end point, and its image *sharply* focused. The image is focused by moving the eyepiece in or out in its telescoping sleeve.

A perfectly defined field is vital for precise reading. Before adjusting focus and illumination in shadow instruments, first turn the analyzer (or in quartz-wedge compensation instruments, the wedge pinion) so that the scale reads some divisions *from zero* to get the full volume of light. After placing the tube of solution in the instrument, the focus must be readjusted.

Every effort should be made to have solutions for polarization absolutely clear. It is advisable to filter solutions, even if made from pure substances, as even a slight opal-

escence due to minute traces of foreign matter affects the definition of the image and consequently seriously affects the precision of the readings.

Practice rapid readings, averaging the results of several rather than fatigue the eye by long observations. Rapidly taken readings, if taken with *care*, are more accurate.

The room temperature, which should be the temperature of the apparatus and solutions, should be recorded at the time of observation.

End Point.—(*Shadow instruments.*) After setting at zero (by the scale), manipulate the instrument so as to move the shadow slightly from one side of the field to the other several times, confining the attention to the central vertical line. Take the point of transition of the shadow across this line as the end point is approached from opposite sides of the field in different observations. This is theoretically the same point as that found by setting the instrument for equal illumination of both halves of the field, but is easier for most observers. This method also enables accurate readings to be taken in certain cases where dust, faulty illumination, imperfect adjustment of prisms, or dispersion variations (in wedge saccharimeters) make it impossible to get both halves of the field to look exactly alike. Of course the field will be equally illumined, in the case of a shadow instrument, when there is a rotatory effect approaching 90° from the true end point, but no shadow effect will appear, as already noted. The general approach toward the true end point will be shown by the rapid darkening of the field as a whole.

If separate scale lights are used, they should be kept turned off except when reading the scale, to prevent heat-

ing the instrument. Any outside glare also quickly impairs the sensitiveness of vision in precise work.

In beginning work with an unfamiliar instrument, set the scale at *zero*, and study the changes of field about this point. This is better than hunting blindly for what you may not recognize, with possible injury to your eyesight if not to the instrument. It is especially important to make this zero setting when some unusual end point is observed, as in the Wild polariscope.¹

Scale Readings. — Always correct for "zero error" (the difference between the end point observed as read on the scale and the zero of the scale), noting whether this is plus or minus. In case zero error is not large, it is better to allow for it in calculations than to attempt to bring the scale into perfect adjustment with the end point. Frequent determinations of zero error should be made, especially if the temperature is changing.

Take the average of at least six readings for all exact work, rejecting the first reading if it shows much discrepancy from the others, or any other of the series which is clearly wrong, owing to some circumstance peculiar to that individual observation, and not affecting the others of the series, as, for instance, eye fatigue, which passes away after a moment's rest.

All saccharimeter scales are expressed in percentages and tenths. Polariscopes measuring rotations directly, except a few of most recent type, give readings in degrees and minutes. Saccharimeter scales are *graduated* into divisions expressing per cents, rotatory scales into halves

¹ Special notes on the use of instruments of different types are given in next chapter.

or thirds of a degree. In both cases, values smaller than these graduations, expressed as fractions of the smallest scale division into which the scale is actually graduated, are determined by "verniers." A vernier, so-called from its inventor, a French mathematician, is a device for reading fractions of the smallest division of a scale. In the form used in polariscopes, it is a sliding scale parallel to and extending along the main scale, graduated in both directions from the zero line which is the index mark whose position the main scale measures.

Each half of the vernier scale extending from the zero mark has a *length* which is, measured in smallest divisions of the main scale, *one less* than the denominator of the fraction which the vernier is designed to determine, while this length of the vernier scale is itself divided into just the number of parts which express this denominator.

For instance, a vernier designed to divide a scale division into *ten* equal parts is itself *nine* scale divisions long, but is divided into *ten* equal parts. Hence in this example each vernier division is $\frac{9}{10}$ of the main scale division. If the zero line of the vernier (which, it must be remembered, is always the index or point of reference of the main scale) does not coincide with a main scale division, but is distant $\frac{1}{10}$, evidently the *first* line of the vernier scale will coincide with the next main scale division line. If the zero mark is distant *two* tenths of the main scale division interval from a line, the *second* line of the vernier scale will coincide with a main scale line, and so on.

The following rules can be given for vernier readings:

(1) First determine the fraction of the scale divisions which the vernier expresses, by actually counting the

number of divisions of the vernier scale, in either direction from zero.

(2) Starting from the zero of the vernier and reading in the direction of the main scale readings, the number of the line of the vernier scale (counting from zero) which coincides with a line of the main scale gives the number of parts of the scale division which the index (zero line of vernier) marks.

Hence, in the case of a vernier reading tenths, if the zero line of the vernier lies beyond the *twenty-sixth* main scale division, and the *seventh* line of the vernier coincides with a line of the main scale, the reading will be 26.7.

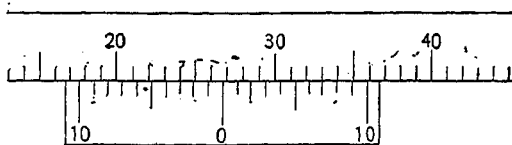

FIG. 15. — VERNIER READING 26.7.

When the zero line of the vernier lies on the *minus* side of the scale, the lines of the corresponding side of the vernier are read. On rotatory scales of polariscopes in chemical laboratories verniers usually read to even minutes only, half degree divisions being divided into fifteen parts, thirds of a degree divisions into ten parts. In reading rotatory scales the number of divisions marked by the zero of the vernier is first read and then expressed in degrees and *minutes*. Not until this is done should the vernier be read and its reading added. Study system of division till you thoroughly understand it before taking readings.

In *rotatory* instruments, the direction of rotation is abso-

lutely determined for rotations less than 180° , but in the case of a quartz-wedge saccharimeter, where the actual direction of the scale readings has no direct reference to that of the rotation of the plane of polarization, the plus direction of the scale is sometimes to the right and sometimes to the left. In most commercial saccharimeters, the plus direction is to the right; in some of the old instruments and in double-wedge compensation saccharimeters, it is to the left. An inspection of the scale will always make clear which is the plus direction of the readings, for, as the scale is designed for measuring sugar, a right (plus) rotating substance, the long end of the scale will be the plus.

Form the habit of checking all observation by taking a final reading of the *large* divisions, independent of the vernier reading. This practice will often detect errors, as an observer naturally tends to concentrate his attention on the more difficult vernier reading, and, becoming careless of the reading of the main scale, often repeats an error once made throughout the whole series of readings.

Calculated results and averages should be carried to one decimal beyond that expressing the limit of scale reading, following the usual practice of physical measurements.

Calculation of Errors of Analysis. — It would seem superfluous to call attention to the importance of calculating the influence of the errors of measurements on the accuracy of polarimetric determinations, were it not that there is abundant evidence that a "profound ignorance" of the elementary principles of the precision of measurements is prevalent among chemists. Much valuable time can be saved and procedure simplified in many cases, if preliminary

calculations of precision are made. Further, with positive knowledge of the limit of precision of all measurements, any uncertainty is reduced to a chance accident or some error inherent in the method.

It is obviously bad practice, for instance, to calibrate a 100 cubic centimeter flask on an analytical balance when it is practically impossible to read the meniscus to a difference corresponding to less than a centigram (and this difference, moreover, representing an error of .01 per cent), leaving out of consideration the fact that with the case filled with moisture, the balance is for some time quite unfit for its necessary uses, as for weighing freshly ignited substances, like ash. It is also easily demonstrated that it is absurd to weigh the normal weight of sugar to milligrams, as recommended by eminent authority.

The discussion of errors of saccharimetric measurements given in the previous chapter will illustrate the investigation of errors of measurement of a polarimetric method.

Notes. — Another vital point in chemical practice which is much neglected, and one not so easy to acquire proficiency in as it would seem, is that of making complete and accurate record of all the experimental data of an analysis. Much valuable work is lost yearly through neglect of proper recording, necessitating a large expenditure of time and labor in repetition. On the other hand, the accurately detailed results of the chemists of fifty years ago are often as valuable as the work of to-day, owing to the complete notes of data which make it possible to recalculate the results by the constants which accord with modern theory and practice.

In polarimetry, owing to much use of constant values of measurement and the mechanical nature of many of the methods, there is more temptation to take data for granted than in procedure where measurements peculiar to each determination make record absolutely necessary. The laboratory records of polarizations should, nevertheless, show exactly the value of each datum. The temperature at which the solutions are made and polarized, as well as the amount and nature of the clarifying agents used, should be recorded also, as these items may well be of consequence, especially in sugar analysis, in the future. The test of the value of a set of notes might be put as follows, — that at any time in the future they prove complete enough to enable an independent worker with a knowledge of the literature of the subject to duplicate the original determination exactly.

Where large numbers of determinations are made by a uniform method, much time can be saved by the use of printed blanks in which appropriate spaces are allotted for data. Any important omission in the record is evident by a glance. Illustration is given of such a blank used by students for records of data of a series of twelve practice determinations in polarimetry. In complicated calculations, such as in the complete determination of hydrolyzed starch products, such blanks, printed or made by hektograph or similar process, are particularly valuable. The computations are greatly simplified by printing the logarithmic constants of calculations in appropriate tabular form, while in addition there is the important advantage already mentioned, that data, always recorded in definite places, can be read at a glance.

MASSACHUSETTS INSTITUTE OF TECHNOLOGY

OPTICAL ANALYSIS OF SUGAR

No.
Date..... Determination.....
..... Instrument..... Light.....
Test..... t
Brix..... t Brix (corrected)..... Sp. Gr.....
 w' N v l
Test : Zero Error :
Flask No.....
Calibration.....
.....
Av..... Av..... Correct reading.....

.....
Instrument..... Light.....
Test..... t
Brix..... t Brix (corrected)..... Sp. Gr.....
 w' N v l
Test : Zero Error :
Flask No.....
Calibration.....
.....
Av..... Av..... Correct reading.....

Result of Tests :

(Signed)

This blank is introduced here merely as an illustration of one applied to a special series of determinations many of which require two separate polarizations and some of which, as glucose and quotient of purity determinations, require Brix or density measurements. As suggested, it is advisable to have data of clarification also. A better title would be "Polarimetric Analysis," as investigation of tartaric acid is also included.

NOTES APPLYING TO SPECIAL INSTRUMENTS

(To be read in conjunction with the General Notes)

A. ROTATORY POLARISCOPES

The Laurent Polariscopes. — See that the lamp is properly adjusted to give an intense flame. The air valve (*V*) should be regulated to give a strong blast, making the blue cones of the inner flame as low as possible. The gauze basket (*A*) holding the salt mixture should be parallel to the flame cones, and be just outside of them, in the hottest part of the flame. If care is taken in this adjustment, the upper part of the flame will be a very brilliant yellow from the incandescent sodium vapor. The salt must be applied every few minutes. The flame should be about 2 decimeters from the end of the polariscopes, the length of an ordinary polariscopes tube, as the condensing lens (*B*) is properly focused on the flame at that distance. (See description of improved lamp in previous chapter.)

Turn the analyzer by pinion *G* till the scale (observed at *N*) reads some degrees from zero, so as to get a bright illumination, and focus sharply with the eyepiece (*O*) on the luminous disk made by the image of the diaphragm opening (*D*) bisected by the quartz plate.

Turn the analyzer to zero, and raise the lever (*U*) on the left, behind the scale disk¹ (*C*), till just enough light passes

¹ In some polariscopes of the Laurent type, especially the German instruments, the adjustment lever of the polarizer is directly *over* the prism, its movement being measured on a graduated scale.

to make a well-defined image in which the shadow changes are easily discernible. This gives maximum sensitiveness.

Determine zero error at 0 and 180°, if the graduation of the instrument admits of readings in opposite quadrants. If the "eccentricity" of the scale is shown to be less than 1' in readings taken at different rotations, observations in the opposite quadrant can be dispensed with henceforth. In

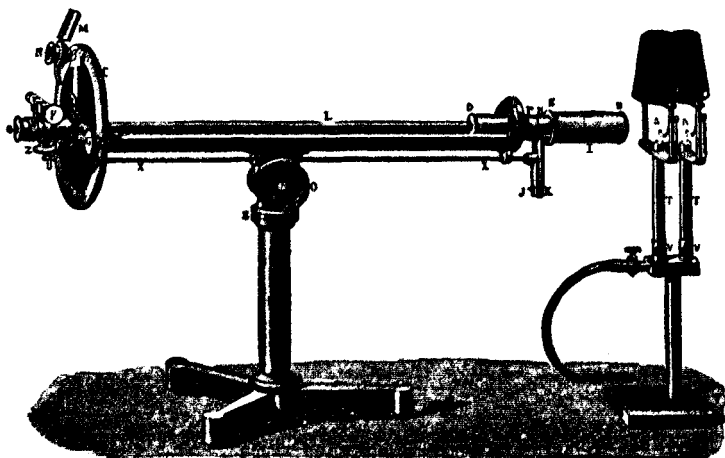

FIG. 16. — LAURENT POLARISCOPE AND SODIUM LAMP.

the larger instruments, the angular-degree scale extends entirely around the circle, the saccharimetric scale being in the upper half of the circle, concentric to it. In the smaller instruments, the degree scale is in one half of the circle, the saccharimetric scale in the other. Study the scales carefully till the graduation is thoroughly understood.

Avoid turning the *adjustment pinion* (*P*) on the eyepiece tube, as this is intended for adjustment of the analyzer

with the scale, and moves the prism independently of the scale.

The angle which the plane of polarization of the polarizer makes with that of the Laurent plate should not be too small, for not only the dimness of the light at the end point prevents distinguishing with precision slight differences of shade, but, inasmuch as the small amount of stray blue rays which pass the bichromate plate are not so completely extinguished, if at all, at the end point, owing to their unequal refrangibility, these may predominate to such an extent when the sodium light is too far reduced by defective working of the lamp or by an excessively small angle between the planes of polarization in the two halves of the field, as to change the "optical centre" of the light and make an error of some minutes in the reading. An angle of 2-4° to the quartz axis (which is one half of the angle of tilting of the planes of polarization) is small enough for most accurate measurements in the work of the chemical laboratory. This angle can be measured roughly, but with sufficient exactness for the purpose, by noting the reading of the scale at which one half of the field is *blackest* when the analyzer is turned a few degrees from zero.

If the lamp and instrument are properly adjusted in the manner described, bright extraneous light excluded, and the direct rays of the blue light of the flame cones of the lamp cut out of the field by a diaphragm, as they are in every properly designed lamp, no error will be introduced in readings certainly as great as 35° within the limit of precision (I') of the ordinary laboratory instrument.

These notes on the Laurent polariscope apply also to the shadow instruments using the Jellet-Cornu prism and

the Lippich polarizer, except what bears obviously on the manipulation of the Laurent shadow device for changing the light intensity. The Duboscq rotatometers usually have an angle of 5° between the planes of polarization of the two halves of the prism, corresponding to 2.5° for the *half* angle measured as described above.

The Landolt-Lippich Polariscopes.—This instrument is made in a variety of forms, and is especially designed for exact physical measurements. The elaborate measuring devices used on the larger instruments for determining optical rotation to $.001^\circ$ need not be considered here, as they are in principle identical with those used in precise physical and astronomical measurements by graduated circles. Some of these instruments have the circle divided into 400 divisions, instead of 360° .¹

¹ The large Landolt-Lippich polariscopes have the scale which moves with the analyzer usually graduated directly to tenths of a degree. "The intervals less than tenths are determined in thousandths by a "silar micrometer." This is a device for measuring the distance that the reference mark (shown in the field of the micrometer eyepiece as a notch at the side of the graduations) lies from the scale line. This is done by moving two parallel cross hairs along the scale by means of a finely threaded screw, the distance traversed being shown on a drum graduated into 100 parts, which revolves with the screw. A complete revolution of the drum (screw) moves the cross hairs exactly one tenth of a degree on the scale, or the distance between two scale lines. Hence, the reading of the micrometer drum when it is set so that a scale line is midway between the cross hairs when taking the zero error must be subtracted from the reading of the drum when it is similarly set for determining the desired rotation value. The reading of the drum obviously gives the hundredths and thousandths of a degree. The readings are more conveniently made if the micrometer is set so that the drum reading is zero when the two cross hairs are symmetrically placed relative to the notch (most accurately determined by first moving the main scale till a long graduation line lies exactly in the notch). Then the readings of the drum directly express the interval in thousandths for each reading after the manner of a vernier. This adjustment can be made by gently moving the drum on the axis of the screw

The illumination of the field of the Lippich polariscope must be adjusted with great care, to prevent surface reflection from the small "half prism" of the shadow device. If the angle of the polarizer is changed during a series of observations, it will be necessary to take new zero readings or bring the analyzer again into zero adjustment by means of the device provided for this purpose.

The Landolt-Lippich polariscope, when used to measure specific rotations for yellow light ("D ray"), has the rays of a sodium chloride lamp passed through a "Lippich sodium-light filter" consisting of two absorption cells, the first, 1 decimeter long, containing a 6 per cent solution of potassium bichromate, the second, .15 decimeter long, containing a solution of uranous sulphate, $U(SO_4)_2$. This, according to Landolt, is prepared by dissolving 5 grams of uranyl sulphate in 100 cubic centimeters of water; 2 grams of zinc powder are added, and then 3 cubic centimeters of sulphuric acid, gradually, in three successive portions. Air is excluded from the flask, which is allowed to stand six hours till the solution has settled. The solution is then filtered into the cell with as little exposure to the air as practicable. The cell must contain as little air as possible and be tightly closed. It is said that this solution will keep a month or more. The bichromate solution takes out most of the blue and green rays, the dark green uranium while the latter is held stationary by the milled heel, as the drum is movable on a friction bearing.

The micrometers on opposite sides of the scale disk can be brought into adjustment to directly indicate the readings α and $\alpha + 180^\circ$ respectively, by setting the notches by a screw on the end of the micrometer box opposite to the drum. When thus adjusted the large Schmidt and Hänsch instruments rarely show differences of $.002^\circ$ in opposite quadrant readings at any part of the scale.

solution taking out the rest, as well as practically all of the red end of the spectrum. The resulting filtered light has, according to Landolt, a wave length of .00058932 millimeter, which represents the wave-length mean of the two *D* lines. In consequence, the rotation values are not strictly comparable with those of the Laurent and other polariscopes using sodium light filtered through a bichromate section, — being about .2 per cent greater.¹

The Wild Polaristrobometer. — This instrument is little used in this country, owing to its unusual end point, not readily distinguishable by an inexperienced observer, and the clumsier arrangement of the apparatus necessitated by the rotation of the polarizer instead of the analyzer. The polariscope is capable of precise measurements, however, when skillfully manipulated. As already stated, the rotation of the polarizer (*D*) is in the *reverse* direction to the rotatory effect of the optically active substance, but in the *same* direction as the *pinion* (*C*) moves by which the observer rotates the prism. The field, except very near the end point, appears as a yellow disk covered with sharply defined, black, horizontal lines like a grating. As the polarizer is turned slowly, and the end point is reached, these lines disappear, as if rubbed out by an eraser, in a broad band which moves across the field. The end

¹ In the writer's experience, the Landolt-Lippich polariscope gives much more unreliable results than the Laurent, if a bichromate solution alone is used as a ray filter. The Lippich polarizer seems much more sensitive to the extraneous rays present in the sodium flame than the Laurent, and in consequence varies its end point by several hundredths of a degree with slight changes of intensity of the flame, — under identical conditions, in fact, where the Laurent gives constant readings. With the Lippich ray filter, the Landolt-Lippich readings are constant at constant temperature. Hence, for general laboratory purposes, the Laurent polariscope is more suitable.

point is taken as the position of the band in the middle of the field when the unextinguished lines of the grating are symmetrically distributed on each side of two cross hairs. The blank appearance at the end point occurs within a very small angle of rotation, and consequently

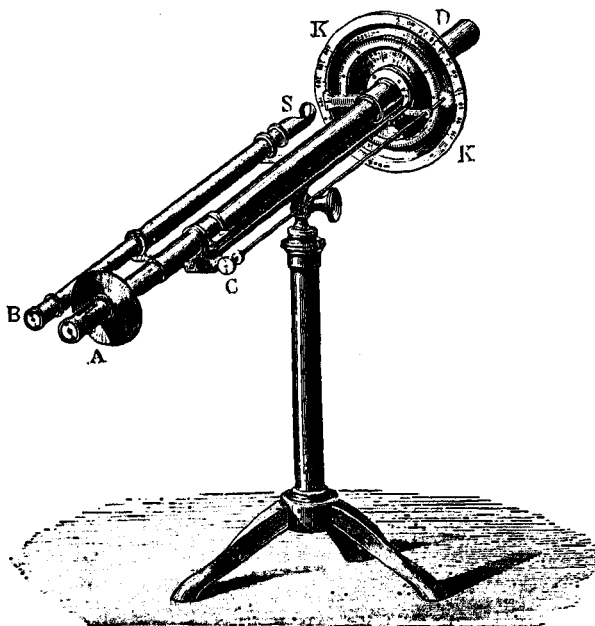

FIG. 17.—WILD POLARISTROBOMETER.

A. Eyepiece. *B.* Telescope for reading scale (*K*). *S.* Mirror for illuminating scale.

is so rapid, as the polarizer is turned, that the inexperienced observer might overlook it altogether. The end point repeats itself every 90° , but the appearance of the field at each end point is not exactly the same, the blank band crossing the field at a different angle in each case.

The Wild polaristrobometer uses a salt flame without any ray filter.

B. QUARTZ-WEDGE SACCHARIMETERS

The Half-shade Saccharimeter. — This is the standard instrument in use to-day. The general method of focusing has already been discussed under General Notes. The mean error of this instrument when the illumination is properly adjusted and the observer expert, is about .02 of a scale division, but under the usual conditions of using

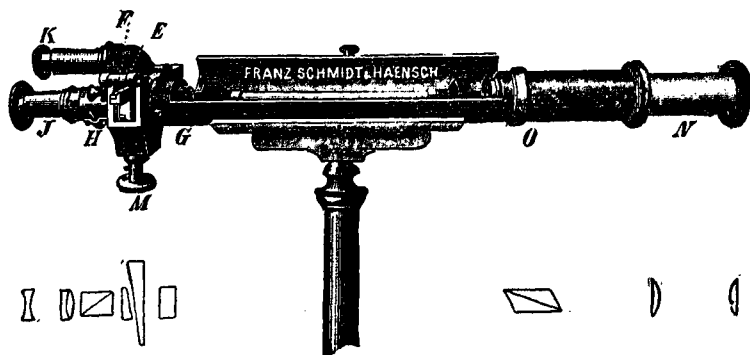

FIG. 18. — HALF-SHADE SACCHARIMETER, WITH DIAGRAM OF OPTICAL PARTS.

F, E, G. Quartz compensator.

H. Adjustment device for rotating analyzer.

J. Eyepiece.

K. Reading glass of scale.

M. Pinion for moving compensator.

O. Position of Jellet-Cornu prism.

N. Condenser.

the saccharimeter it is somewhat greater. The light should fill the field uniformly, and not pass too obliquely through the Jellet-Cornu prism (whose position in the instrument is indicated at *O*), or the surface of the prism with its bisecting joint is too sharply defined (as well as any dust that may be on its surface). The lamp and condensing lens of the saccharimeter, the latter adjustable in a sliding sleeve (*N*), should be arranged to pass the rays practically parallel,

or slightly convergent. Landolt recommends that the condensing lens be so placed relative to the lamp that it focuses on the analyzer diaphragm.¹ The field will then be always uniformly illuminated, with the surface of the prism practically invisible, the bisecting line showing very faintly at the end point.

Not infrequently, at the zero end point, the field will not appear quite uniform, one half having a faint bluish tint, while the other appears faintly brown. This is caused by a slight displacement of one of the prisms, and can be corrected by slightly rotating the *analyzer* by means of the adjustment provided for the purpose. In the older instruments this is done by a key, which will be found in the instrument box, and which fits a pinion (*H*) on the under side of the eyepiece tube. This pinion turns a gearing that revolves the analyzer. The newer instruments have a somewhat different device. On each side of the eyepiece tube (*J*) there are two steel screws with projecting heads. These screws have conical points which bear eccentrically on the edges of two holes bored in a rotating sleeve which carries the analyzer. By loosening both screws, and then turning one or the other down slightly, the effect is to turn the sleeve in a direction depending of course on which screw is turned, the rotation resulting from the pressure of the coned point against the side of the hole in the sleeve. After the analyzer is turned to correct adjustment, the screw which was *not* used to turn the sleeve is very carefully tightened till it just bears, in order to fix the analyzer in position. Extreme care should

¹ This applies only to the latest type of half-shade saccharimeters fitted with the Lippich polarizer and a specially constructed condenser.

be exercised in making this adjustment, as it is one of delicacy. The method of adjusting is as follows: The prism is turned, *very slightly*, and the wedge moved by the pinion (M) till the field is as evenly tinted as possible. If the disparity of tint at the end point is diminished, turn the analyzer farther in the same direction till no difference in tint appears when the wedges are adjusted to even shade. If the disparity of tint increases on turning the prism, turn in the opposite direction, each time always adjusting the wedge for a field of uniform shade (being also as even a *tint* as possible), independently of the scale reading. After the field is both evenly tinted and shaded at the end point, the scale may be brought into adjustment by setting the vernier zero to the scale zero by means of the key found in the box. This key fits on an adjustment pinion at the left end of the vernier scale (not shown in cut).

Many observers prefer to correct for any disparity of tint at the end point by using an absorption cell of potassium bichromate solution. Many of the modern instruments are provided with such an absorption cell, which fits into the polarizer end of the saccharimeter. This cell absorbs the blue rays, which make the most disturbance, and gives an agreeably tinted field of uniform shade and tint at the end point even if the prisms are slightly out of adjustment. This cell is necessary when solutions of a slightly different dispersive power from quartz are polarized, commercial "glucose," for instance. In fact, if white light is used, there will be a slight disparity of tint at high rotations, even with cane-sugar solutions, as the dispersive powers of cane sugar and quartz differ some-

what at the blue end of the spectrum. A piece of brown (carbon) tinted glass is a very good substitute for the bichromate cell, although it does not cut off the blue rays quite as effectively. It may be well to note again the considerable error caused by varying temperature. For accurate work it is necessary that the saccharimeter be exposed for at least an hour to a temperature practically uniform with that at which the readings are made. The exact graduation should be established by means of standard quartz plates of known values, since instruments are graduated by at least two systems, as has already been noted, one based on the Mohr cubic centimeter of 17.5° , — the original Ventzke and established commercial standard; the other, the official standard of the United States Custom House, based on true-cubic-centimeter volumes.¹

The Triple-shade Saccharimeter.—This instrument differs from the standard commercial saccharimeter only in the end-point device, which is the Lippich triple-prism polarizer, the essentials of which are a large Nicol prism, and two smaller Nicols placed close to the large Nicol, between it and the analyzer. These two smaller “half prisms,” as they are called, have their vibration planes parallel to each other, but at a slight angle to that of the larger Nicol. The light from this polarizer passes through the circular opening of a diaphragm in such a way, and

¹ Apparently some saccharimeters, especially the later ones, are graduated to give exact percentages of cane sugar at all concentrations. Such scales are not strictly proportional to the quartz rotation values, as the specific rotation of sugar increases slightly with diminishing concentration. Hence the surface of the “wedges” must be curved or the divisions vary in size. Many of the newer instruments, graduated for true cubic centimeter flasks, when compared with the Ventzke graduation, show at the 100 point the ratio, 1.00000 : 1.00234, but in the middle of the scale, 1.00000 : 1.0033.

the half prisms are so arranged, that the field is trisected vertically by the edges of the two half prisms. The diagram shows the position of the prisms relative to the field of the instrument. The circle represents the field defined by the diaphragm opening; *A* and *B* show the positions of the half prisms and *C* that of the large Nicol. Then, if the vibration planes of the two half prisms are taken parallel to aa' and bb' , and cc' , inclined at a small angle to aa' or bb' ,

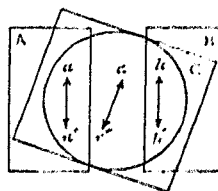
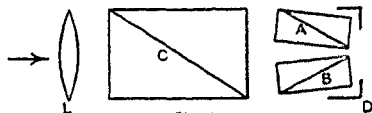

FIG. 19.

cc', represents the vibration plane of the large Nicol *C*; the field will be equally illuminated when the vibration plane of the analyzer is at right angles to a line bisecting the angle made by the vibration plane of the Nicol *C* and that of either half prism *A* or *B*. The diagram in plan shows the position of the prisms relative to the light



PLAN
FIG. 20.

passing through the instrument along its axis in the direction shown by the arrow through the lens *L*, the diaphragm being at *D*.

It will be noticed that the

half prisms are slightly canted longitudinally. This is to insure a sharp focus on the edge of the prism, so that its image at the end point will be a faint hair line.

Obviously, the light effect in the two side sections of the field is the same when the plane of the light is rotated, the contrast being between these and the central section, instead of in the halves of the field as in the half shade saccharimeter. Owing to the agreeable effect of the

triple-shade field, this instrument has become very popular. However, on account of the complication and delicacy of the prism combination, it is much more liable to get out of adjustment, the exact parallelism of the two half prisms being difficult to maintain. It is therefore doubtful whether, under the ordinary conditions of its use in the sugar laboratory, it really gives readings of greater precision than those of the half-shade saccharimeter, especially when the latter has its illuminating apparatus adjusted to give the best field for accurate reading.

Variations in temperature will apparently affect the half-prism adjustment, as well as any shock or jar to the instrument. The result is that the field at the end point will not be perfectly evenly illuminated, but one or the other of the side sections will show a faint shading. There will be, in consequence, two end points, depending on which side of the field is evenly illuminated with the central section. Usually this disparity is less than .1 of a scale division, but the precision of the instrument is lowered by that amount, unless the observer goes through the tedious process of taking the average of the readings by *each* end point, and thereby halves his error. This defect, however, is an annoying one and of course does away with any superiority of precision over the simpler half-shade type.

If the theory of the Lippich polarizer is thoroughly understood, any one experienced in working with delicate instruments can adjust the half prisms to parallelism in the following manner: Remove the screws in the metal sheath of the enlarged part of the tube containing the polarizer. Take the sheath off, which will expose the half prisms in

their brass mountings. Both of these mountings can be rotated through a small angle, and one is provided with coned-screw adjustments for making a very small rotation, exactly as described in the Notes on the Half-shade Saccharimeter. If the screws of the slotted guides holding

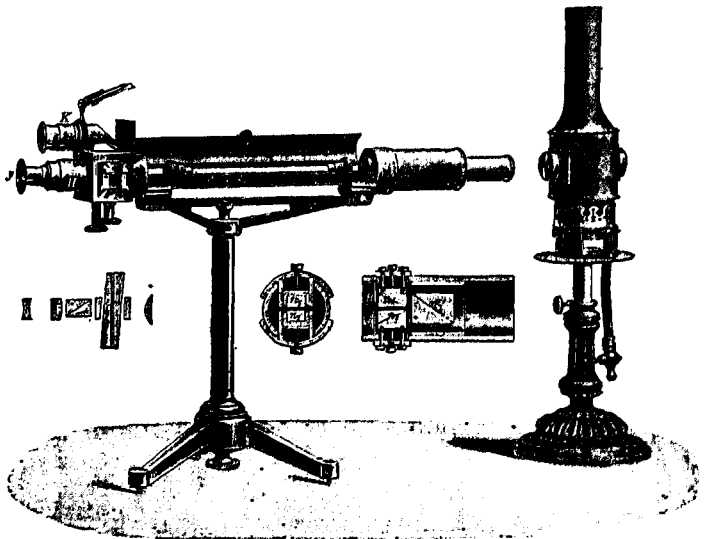

FIG. 21. — DUBILLE-WRIGHT, TRIPLE-SHADE SACHARIMETER WITH DIAGRAM OF OPTICAL PARTS.

N_1, N_2 . Half prisms. N_3 . Polarizer.

the mounting of the prism to be rotated are loosened, then the delicate adjustment to parallelism can be made with the coned screws, in a similar way to that already described. When the field shows perfectly uniform illumination at the end point, the screws in the guide slots are gently tightened to hold the mounting in position. Considerable skill and patience are required to make this adjustment. Great

care should be taken to move *only* those screws which have to do with this adjustment, as there are other screws which rotate the prism longitudinally.

The newer triple-shade as well as half-shade saccharimeters have the scale illuminated by means of a small mirror over the scale, which throws the light of the main lamp of the saccharimeter down through a ground glass upon the scale. This obviates the necessity of a separate scale light. If the saccharimeter is screened from the light by a partition, or placed in a hood, care should be taken to have the hole through which the light passes large enough to allow a diagonal ray to the mirror. A mirror of any kind fastened to the top of the hood by means of a stiff bent wire, when properly placed, works well with the older form of scale apparatus. A cheap, silvered-glass concave reflector, such as used with an ordinary kerosene lamp, works excellently.

The Soleil-Ventzke-Scheibler Transition-tint Saccharimeter.— This instrument, which was the standard commercial saccharimeter less than fifteen years ago, is now almost completely replaced by the half-shade type. It takes considerable practice to get high precision in observations with a transition-tint saccharimeter, but an expert with a good eye for color can read the tint transition as accurately as the half-shade end point, unless possibly in the case of very highly colored solutions, such as low-grade molasses. The errors of reading such solutions are, however, much less than others peculiar to polarizing such products, to be discussed later. The normal weight used with this instrument (26.048 grams) and in fact all the working parts, except those which have to do with the

special end-point device, are identical with those of the half-shade saccharimeter.

The method of using this instrument is as follows: Focus the eyepiece (*J*) on the transition-tint plate, which will appear as a party-colored disk of two contrasting colors, each occupying one half of the field on each side of a central vertical line. Turn the scale to zero, or till both halves of the field are of the same tint; then turn the button

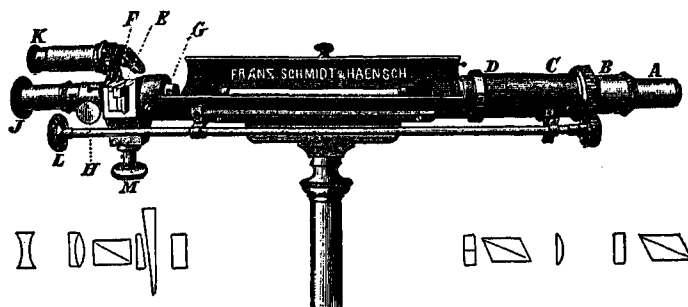

FIG. 22.—SHELL-VRENTZKE-SCHEIBLER TRANSITION-TINT SACCHARIMETER.

- | | |
|--|---|
| <i>A.</i> Shows position of Nicol of tint producer. | <i>F, E, G.</i> Quartz-wedge compensator. |
| <i>B.</i> Position of quartz plate of tint producer. | <i>H.</i> Adjustment device of analyzer. |
| <i>C.</i> Position of polarizer. | <i>J.</i> Eyepiece. |
| <i>D.</i> Position of transition-tint plate. | <i>K.</i> Reading-glass of scale. |
| | <i>L.</i> Pinion for setting sensitive-tint producer. |
| | <i>M.</i> Pinion for moving wedge. |

on the end of the long rod (*L*) at the right of the eyepiece, which turns the Nicol of the "sensitive-tint producer," till a suitable tint is produced in the field for a background against which the eye can most readily distinguish the delicate rose tint which appears in one or the other half of the field when the wedge is almost at the end-point position. The tint chosen varies with different observers. It is always a very pale one, flesh or pearl, practically white. The end point shows both halves of the field evenly tinted

with this sensitive color, but at the slightest turn of the wedge pinion a pale rose flush will appear in one half of field or the other. The light from the lamp should be soft and diffused, not too bright. In taking zero observations, many place a tube full of water in the instrument to soften the light. As the eye becomes fatigued quickly, and loses its maximum sensitiveness for distinguishing slight changes in tint in a few moments, rapid readings should be made. All glaring outside light, especially if colored, should be excluded, the observer being in comparative darkness. When a *colored* solution is placed in the instrument, the sensitive tint must be again adjusted till the color is obtained which proves most sensitive for observing the end-point transition. With *lightly colored* solutions of molasses or molasses sugars, the transition change appears as a *shadow*, owing to the practically complete absorption of the tint by the deep brown-red of the caramel substance of the molasses.

Occasionally, especially in an old instrument, the prisms become displaced sufficiently to affect the sensitiveness of the readings, the field not appearing perfectly uniform at the end point. The quickest and surest way to bring the instrument in adjustment is to remove the quartz-wedge compensation entirely, and then adjust the analyzer till the field is evenly tinted. As in the adjustment of the analyzer in the half-shade saccharimeter, this is done by means of a key which turns a pinion (*H*) on the under side of the eyepiece tube. To remove the compensator, slip out the movable wedge (*E*), unscrew the brass plate carrying the fixed wedge (*F*) and the vernier scale, and finally, remove the left-rotating quartz section which is the last optical

part on this end of the instrument going toward the polarizer. This is done by unscrewing the brass ring of the mounting, (*G*) from the trough side.

The Soleil Duboscq Transition-tint Saccharimeter. — This instrument has been entirely superseded in commercial work by the improved modern types of quartz-wedge saccharimeters. The wedges of the Duboscq instruments are well made, however, and in the hands of a skillful worker it is a precise instrument to at least .2 of a division, an accuracy sufficient for many laboratory measurements. A conscientious and painstaking observer with a good eye for color can make efficient use of such a saccharimeter, since its deficiencies are largely those of inconvenience and difficulty of manipulation, and these can be supplemented by exercising a correspondingly greater skill in working with the instrument. The young chemist is apt to condemn too hastily any laboratory instrument which is not of modern type, when a little practice and a study of the nature and magnitude of the errors of analysis would show that such apparatus fulfills all the requirements of the work at hand. Of course, in the case of large commercial laboratories, where accuracy with speed and uniform trade methods are the leading considerations, the standard modern saccharimeter is indispensable.

The fundamental principles of the working of the Duboscq-Soleil saccharimeter are identical with those of the Soleil-Ventzke, but the details of the apparatus are considerably different. Both wedges of the compensator are moved by the pinion past each other, instead of one being fixed as in the modern instrument. The scale, which is graduated for a normal weight of 16.35 grams, or what

was taken as the equivalent of the rotation of a millimeter section of quartz, has no vernier, and reads from right to left, the fractions being estimated by aid of a hand magnifier. The sensitive-tint producer is in the eyepiece,¹ which latter in consequence moves in a slotted guide to avoid any disturbance of the tint in focussing. The Nicol for producing the sensitive tint can be rotated through a half circle by means of a milled ring on the eyepiece tube.

A trough can be made very cheaply which will fit into the instrument and so allow the use of the more convenient modern tubes, which are of smaller diameter.

Double-wedge Saccharimeters.—In these instruments, the scales read to the left, the figures of the “working wedge” scale being in black and those of the “control wedge” in red. The pinion head of the “control wedge” is also of a different color from that of the “working wedge,” and placed at a different level to avoid confusion. Double-wedge scales have read from right to left in all saccharimeters of this type which have come under the author’s notice. The scales do not have minus graduations, as left-rotating solutions can be read by using the control wedge as the working wedge. When a double-wedge saccharimeter is in adjustment, and no optically active substance is in the instrument, the end point is always given when the wedges are so adjusted that both scales read alike, independently of the numerical value of the reading. (See Figures 10 and 21.)

¹ It is interesting that the illustration of a saccharimeter in Clerget’s original article on sugar-testing, written in 1849 (*Ann. Chim. Phys.* 26 (3), 175), shows an arrangement of tint producer identical with the modern instrument of Scheibler.

POLARIZATION OF CANE SUGAR.—GENERAL COMMERCIAL METHODS

Sampling.— In most commercial analyses the sugar is determined as a per cent by weight of the original product as it is bought and sold in the market. The sample which the chemist polarizes must be strictly representative of the total lot of sugar, which may amount to several thousand tons. The sampling of such large lots of sugar entails much labor, and in the case of raw sugars is usually done by men specially trained for this work. Great care has to be exercised, as it is by no means easy to get a representative sample. Not only is sugar bought and sold on its percentage value, but the government assesses import duties based on the polarization, which may amount to from 30 to 50 per cent of the total value of the cargo. Raw sugar reaches the market in diverse forms of package. The old-fashioned "open kettle" or muscovado sugar, some of which is still shipped, comes in hogsheads of from 1500 to 1650 pounds. The modern West Indian sugar houses usually ship in burlap bags of 300 pounds. The Hawaiian sugar comes in 125-pound bags. The Javan sugar is packed in cylindrical bamboo crates, holding about 700 pounds. Some sugar is packed in wooden boxes, and the primitive palm sugars of the East come in bamboo "mats."

The sampling of raw sugars is especially difficult because the product contains considerable moisture from the

molasses, which is retained by the spongy mass of crystals, the amount varying greatly with the quality of the sugar. This molasses tends to drain from the upper layers of the package and collect at the bottom. Most sugars exposed to the air rapidly lose their moisture. In consequence, sugar samples taken from different parts of a package may differ appreciably in polarization. The method of sampling found most satisfactory in practice is to thrust a long metal tube, known as a "trier," through the whole bulk of the package, in a line extending diagonally from the top of one side to the bottom of the other.¹ By rotating the trier, it is filled with sugar its entire length.

In this way each package, or a certain percentage of the packages, of the cargo is sampled, and the sugar from the sampling transferred as quickly as possible to a covered can or metallic box to prevent drying. After a thorough mixture of this large sample, small samples are taken from it which are put into tin boxes holding half a pound or so. These are tightly covered and often sealed by dipping the box in paraffin. It is in this form that the samples go to the laboratory. Molasses or sirups are sampled by running a stick into the bung-hole of the barrel or hogshead and draining off the adhering liquid into a bottle.

Method of Polarizing. — The commercial method of polarizing is as follows: Mix the sample thoroughly, breaking up all lumps. This is best done by pouring out the contents of the box upon a sheet of ordinary brown calendered wrapping paper, or, better, a sheet of plate glass. Weigh out the normal weight of sample in the tared German-

¹ Bags and baskets of "centrifugal" sugars are sampled by driving the trier in at the side so as to sample the central contents.

silver dish provided for the purpose, weighing to .005 gram. The preparation of the sample and the weighing should be done as quickly as possible and the remainder of the sample returned to the covered box at once to avoid change from evaporation. Pour about 50 cubic centimeters of water, at room temperature, into the dish, and stir up the crystals from the bottom with the little metallic pestle provided for the purpose. It is usually not necessary to grind the sample with the pestle in dissolving, as this does not materially assist solution,¹ and wears the dish. Pour off the solution into a 100-cubic-centimeter graduated flask, taking especial care not to pour out any undissolved sugar. Very fine crystals are often carried into the flask if care is not taken to prevent it, and, settling to the bottom, remain undissolved. Add a little water to dissolve the rest of the sugar in the dish. There is usually left a slight residue of insoluble matter, sand or dirt.

As aqueous solutions of raw sugars are practically opaque from the presence of albuminoid and other vegetable extractive matter in a colloidal state, it is necessary to use some precipitant to clarify the solution in order to get it into a suitable condition to polarize. A solution of basic lead acetate of a density of 1.25 is the clarifier almost universally used.

After the solution has been entirely washed into the

¹ Another method of solution is to wash the sugar through a wide-mouthed funnel directly from the dish into the flask by means of a wash bottle or other convenient jet apparatus. The flask is filled about three quarters full, and is shaken till the sugar is dissolved. This is the official German method. With a large number of samples it is quicker, as the flasks can be placed in a shaking machine and all shaken at once. With a few it is slower, but it has the advantage that the weighing dishes are not worn by any grinding.

flask, allow it to stand a few minutes so that any solution in the neck may drain off, add 2 cubic centimeters of basic lead acetate solution, and make up to the graduation mark with water. If foam prevents the reading of the meniscus, add a drop of ether, or better, spray a little ether into the flask with an atomizer. This will immediately dissipate the foam. Shake the solution and filter through a dry filter into a (dry) cylinder, rejecting the first few drops. Cover the funnel with a watch-glass to avoid evaporation.

The amount of lead acetate solution necessary for clarification varies with the nature of the sugar polarized.¹ No exact rule can be given. Use as little as possible. If too little lead solution is used, the clarification is incomplete; if too much, the solution soon clouds after filtering from the formation of basic salts or carbonate. If the right amount of lead has been added, and thoroughly mixed through the solution, after a few minutes a distinct coagulation will be noticed, the particles gradually settling out and leaving at the surface a comparatively clear solution. The addition of about 2 cubic centimeters of "alumina mixture" — a solution of alum almost completely precipitated by ammonia so as to be practically a creamy mixture of aluminum hydrate in ammonium sulphate solution — assists clarification and removes any excess of soluble lead.² A 5 per

¹ Another method of clarification has been proposed very recently by Home (*J. Am. Chem. Soc.*, XXVI, 186), which is designed to obviate the effect of the volume of the precipitate on the concentration. In this method the solution is made up to 100 cubic centimeters *previously* to clarifying. A sufficient quantity of basic lead acetate in *powdered* form is added and the solution filtered.

² This is important if the solution is to be inverted by the Clerget method (described in the next chapter), to prevent removal of hydrochloric acid by the lead in the filtrate.

cent solution of common salt is also excellent for the latter purpose.

Dark solutions, as from molasses, sometimes require either diluting or the use of the 1-decimeter tube.¹ Occasionally the solution is decolorized by placing a gram or so of prepared bone black in the dry filter. Owing to the initial absorption of sugar by the black, the first 30 cubic centimeters of the filtrate should be rejected. Decolorization by bone black should only be used as a last resort. Highly refined sugars, such as granulated, usually need no clarification other than simple filtration. Often, when a precipitant is necessary, the alumina mixture alone suffices.

Polariscope Tubes.— In filling tubes avoid air bubbles. These obviously cut off the field and impair the definition unless very small, when they need not be considered. Rinse the tube twice with the solution before filling.

Before placing a tube in the instrument wipe carefully, and see that the outside of the cover glasses is clean and free from moisture. If objects cannot be seen clearly and without distortion when looking through the tube, it is useless to try to make a polariscope reading, and it should be refilled. If the tube is handled much, the heat of the hand will temporarily disturb the solution, causing a turbidity which will soon clear.

In placing caps on polariscope tubes, note that the number

¹ Sawyer (*J. Am. Chem. Soc.*, 27 (July)) shows by many experimental data that it is better to polarize low grade molasses in fifth normal solution (26.048 grams in 500 cubic centimeters). Aside from the greater convenience in making up the solution and the saving of eyesight in reading the lighter colored filtrate, less than one half as much basic lead acetate is necessary; hence, the errors due to clarification are correspondingly decreased, as is the effect of the bulk of the precipitate in the larger volume of solution. These advantages more than compensate for the increased errors of reading.

or symbol on the cap corresponds with that on the tube. This will prevent jamming or sticking of the caps. The friction caps of the Landolt tubes should be firmly seated by pressing them on with a rotary motion. Screw caps should be screwed on firmly and then very slightly slackened, so that the pressure on the cover glass is from the expansion of the soft rubber washer which is a necessary fitting in the cap of both types of tube. See that this washer is always in the cap.

After using, all apparatus that has been in contact with solutions should be thoroughly washed with running water and placed in a rack to dry (not wiped). This will insure a constant supply of clean *dry* apparatus. Take care to wash the brasswork at the ends of the tubes, especially the Landolt, or the caps will stick. After washing, leave cover glasses out, but place *caps* on the ends of the tubes so as to protect the ground surfaces from being chipped by any chance knock. The lead used for clarifying in sugar solutions gradually clouds glassware. Remove by occasional washing in hydrochloric acid. If cover glasses stick in the caps, force them out with a clean stick of *wood*; do *not* use metal or glass. Care should be exercised to avoid scratching the cover glasses in any way. Scratched cover glasses should not be used. Glass polariscope tubes are preferable to metal ones from their greater cleanliness and because they are less affected by temperature changes.

The brass mountings at the ends of glass tubes should always be examined before using the tubes, as they occasionally work loose and become pushed out so that the cover glasses bear on the brass and not on the ground-glass ends of the tube as they should. By gently heating the end

of the tube till the resinous cement which holds the mounting melts, the brass collar can be pushed back till the ground end of the tube is just exposed, and allowed to cool in this position till the cement hardens. A good quality of sealing wax makes a good cement, or better, especially in warm climates, a mixture of litharge and glycerine, which rapidly hardens when gently heated.

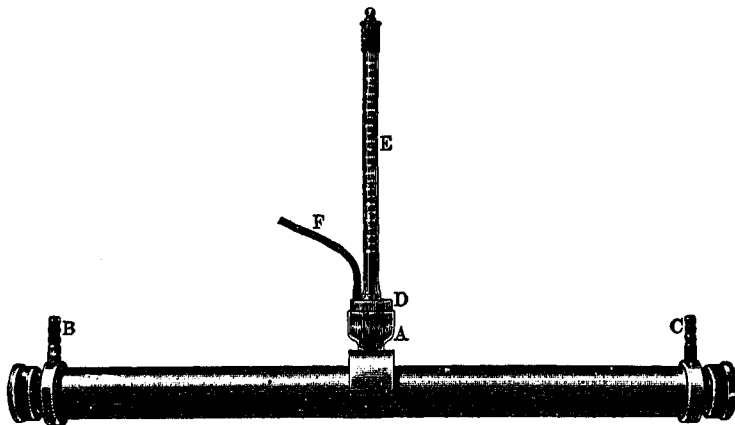

FIG. 23.— WATER-JACKETED TUBE FOR POLARIZING AT CONSTANT TEMPERATURE.

- | | |
|---|---------------------------|
| <i>A.</i> Tubulus for thermometer. | <i>D.</i> Rubber stopper. |
| <i>B, C.</i> Water jacket connections. | <i>E.</i> Thermometer. |
| <i>F.</i> Air vent for equalizing pressure on liquid in tube. | |

Tubes for ordinary laboratory instruments are usually made of three lengths, 1, 2, and 4 decimeters. The standard tube for commercial work is 2 decimeters in length. Tubes used for inversion readings, to be mentioned later, are 2.2 decimeters long and provided with a tubulus for holding sufficient solution in which to immerse a thermometer bulb for taking the temperature of the solution in the tube during readings. Preferably such tubes are sur-

rounded by a circulating-water jacket for maintaining constant temperature.

Certain forms of tubes have been designed with an enlarged chamber to trap any air bubbles which might accidentally be introduced into the tube, and keep them out of the optical field of the saccharimeter. With ordinary care in manipulation no such devices are necessary.

Pellet has devised a "continuous diffusion" tube which by means of tubulature connections can be filled without removing from the saccharimeter. This apparatus is very useful where a large number of polarizations are to be made quickly, as in valuing beets.

Of course if l is not 2, v not 100, or the weight of sample taken (w') not the normal weight (N), the reading of the saccharimeter will not express directly the per cent of sugar. If, for instance, the weight of sample is other than the normal weight, the percentage will be given by the following equation, $P = R \frac{N}{w'}$, where R is the reading, and P is the per cent required.

Manipulation of the Schmidt and Hänsch Control Tube.—The principles on which the use of this* instrument depends in its application to the calibration of saccharimeters have already been explained. The method of manipulation is as follows: Extend the tube to practically its full length, insert funnel plug (not shown in cut), and fill with the sugar solution through one end in the same way as a tube of the ordinary type.¹ Remove plug, and shorten the tube a little by moving the pinion (N) slightly.

¹ The tube at the funnel end requires a cover glass larger than the ordinary size.

This will make the solution fill up the plug hole. Put the funnel (*T*) in place and fill about a quarter full with the solution, taking care not to let air into the main tube when inserting the funnel. It is advisable to pour a few drops of the solution through the funnel before placing the latter in the tube, as this insures displacement of the air in the neck, which might otherwise be forced into the tube. The pinion should work stiffly enough to avoid changing the length of the control tube in handling. Owing to the absorption of the packing of the telescoping joint at *C*, the

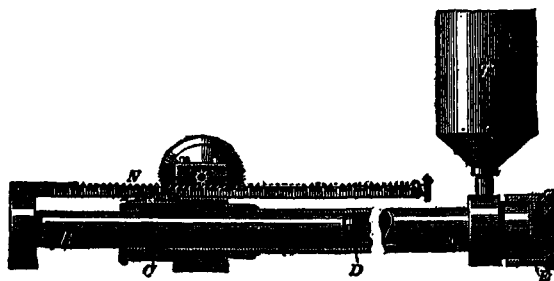

FIG. 24.—CONTROL TUBE.

control tube must be much more thoroughly rinsed with the solution than an ordinary tube, especially if solutions are changed in calibrating. Obviously, too, the tube must be particularly carefully washed and dried after using. A vented cap should be used on the funnel to avoid evaporation.

It is vital for accurate work that the temperature be constant during the readings.

Chemically Pure Sucrose for Standardizing Saccharimeters.—The purest commercial sugar (white granulated or “rock candy”) is made up to a hot saturated solution. The sugar is precipitated by pouring the solution into absolute alcohol, and the crystals separated by a small

centrifugal and washed with the same alcohol. The sugar is then redissolved and the same procedure repeated. The crystals are then dried in a vacuum desiccator and kept in a tightly closed glass vessel.

Errors of Commercial Polarizations. — Besides the errors of polariscope and saccharimetric measurements already discussed, there are others peculiar to the standard commercial method, and dependent on the nature of the impurities present in the sugars themselves. Although an immense amount of work has been done in the investigation of these errors, yet they are little understood, and practically are ignored in commercial analysis for the chief reason, perhaps, that experience has shown, in the case of the ordinary class of commercial sugars, that the total errors apparently balance each other very closely, with the result that polarizations made at average room temperature by the standard commercial methods give with requisite accuracy the per cent of sucrose in the sample. The effect of temperature variation has already been noted.

The bulk of the precipitate from the lead clarification has always been neglected in commercial polarizations, being reckoned as part of the solution in making up to volume, partially on the ground that its volume largely results from water of hydration abstracted from the solution. Many investigations have been made to determine the volume of this dried precipitate, as well as in study of the effects of adding to sugar solutions known volumes of material of a nature supposed to be similar to the impurities present in the natural products. None of this work has thrown much light on the question, partially from the difficulty in getting at the exact conditions of the forma-

tion of the precipitate, and also because, in the case of low-grade sugars, where this effect of the precipitate volume is greatest, the lead solution exerts other little-understood influences on the rotation of other impurities present. Therefore, the disturbing effect is the resultant of several influences, varying with the nature of the impurities and the conditions of clarifying. These errors in general seem to increase the polarization, while temperature errors as a rule decrease the readings. Consequently, it is questionable, in the interests of scientific accuracy, whether *any* correction should be made, in raw sugar polarizations at least, till *all* the disturbing influences can be accurately controlled. Otherwise nothing is gained in the approach to the true saccharimetric value. As already stated, there has been a general agreement among sugar chemists to make polarizations at 20°. Scheibler first devised a method of "double dilution" to eliminate the effect of the bulk of the precipitate. His method, as modified by Wiley, requires two polarizations to be made, one of a solution made up at the normal concentration, the other at a concentration of twice the dilution, that is, the normal weight of sample dissolved in 200 cubic centimeters of solution, the amount of lead acetate solution added before making up to volume being exactly the same in both cases. It can be shown mathematically,¹ that if *a* represents the reading of the normal solution, and *b* that of the diluted solution, then the true reading of the solution at an actual concentration of the normal weight in 100 cubic centimeters will be given by

the formula, $R = \frac{ab}{a-b}$.

¹ Wiley, *J. Am. Chem. Soc.* 18, 430.

The lower grade raw cane sugars, as also cane juices and sirups, always contain an appreciable amount of the glucose type of sugars. These are to some extent present in the original cane juice, and in part are formed from the decomposition of the cane sugar in manufacture. Whether the glucose sugars from these different origins are identical or not has not been settled by sugar chemists. It is known that the mixture of glucoses from the decomposition of cane sugar have a left-rotatory effect, while there is much evidence that the glucose sugars in commercial cane products are optically inactive. Moreover, it is known that basic lead acetate changes the rotations of these glucoses, certainly in the case of those which are derived from the decomposition of the cane sugar during manufacture. Although these facts are most suggestive, they have not yet led to any accurate methods of estimation of the errors of polarizations introduced by the action of lead acetate, or their prevention. The addition of acetic acid to break up these levulose compounds is a questionable expedient.

Beet sugar products, even of low grade, are practically free from reducing sugars, but contain small quantities of a polysaccharide substance known as raffinose. This has a strong specific rotatory power (about 105°) and in some cases makes an appreciable error in polarization.

Errors due to Change in Specific Rotation of Sucrose at Low Concentrations. — The specific rotation of cane sugar is not exactly a constant at all concentrations of its aqueous solution, as has already been stated. Hence, the readings of sugar solutions of different concentrations on the saccharimeter are not strictly proportional to the thickness of the compensating quartz section, if the saccharimeter

is graduated so that any reading n represents a position of the wedge corresponding to a section of compensating quartz $\frac{n}{100}$ of the thickness of quartz compensating at the 100 point. In other words, a quartz-wedge saccharimeter whose wedge surfaces are perfect planes and whose scale divisions are equal does not give a perfectly exact reading of the sugar per cent at all parts of the scale.

Schmitz has calculated the following table giving the exact saccharimetric value for each division of the saccharimeter :

READING.	PER CENT OF SUGAR	READING.	PER CENT OF SUGAR	READING.	PER CENT OF SUGAR	READING.	PER CENT OF SUGAR
1	1.00	26	25.94	51	50.92	76	75.94
2	1.99	27	26.94	52	51.92	77	76.94
3	2.99	28	27.93	53	52.92	78	77.94
4	3.99	29	28.93	54	53.92	79	78.94
5	4.98	30	29.93	55	54.92	80	79.95
6	5.98	31	30.93	56	55.92	81	80.95
7	6.98	32	31.93	57	56.92	82	81.95
8	7.98	33	32.93	58	57.92	83	82.95
9	8.97	34	33.93	59	58.92	84	83.95
10	9.97	35	34.92	60	59.92	85	84.96
11	10.97	36	35.92	61	60.92	86	85.96
12	11.97	37	36.92	62	61.92	87	86.96
13	12.96	38	37.92	63	62.92	88	87.96
14	13.96	39	38.92	64	63.92	89	88.97
15	14.96	40	39.92	65	64.92	90	89.97
16	15.96	41	40.92	66	65.93	91	90.97
17	16.95	42	41.92	67	66.93	92	91.98
18	17.95	43	42.92	68	67.93	93	92.98
19	18.95	44	43.92	69	68.93	94	93.98
20	19.95	45	44.92	70	69.93	95	94.98
21	20.95	46	45.92	71	70.93	96	95.98
22	21.94	47	46.92	72	71.93	97	96.99
23	22.94	48	47.92	73	72.93	98	97.99
24	23.94	49	48.92	74	73.94	99	98.99
25	24.94	50	49.92	75	74.94	100	100.00

Some of the modern saccharimeters are graduated to give strictly correct readings of sugar per cents at all parts of the scale. Apparently this is done by giving a slightly curved surface to the wedge.¹

SOME IMPORTANT PAPERS ON ERRORS IN SUGAR POLARIZATIONS

- Welz—1867. *Zeit. Ver. deut. rüb. zuck. Ind.*, 17, 489.
 Maumené—1870. *Comptes rendus*, 69, 1306.
 Scheibler—1870. *Zeit. Ver. rüb. zuck. Ind.*, 20, 218.
 Gill, C. H.—1871. *J. Am. Chem. Soc.*
 Scheibler—1875. *Zeit. Ver. deut. rüb. zuck. Ind.*, 25, 1054.
 Scheibler—1876. *Ibid.*, 26, 724.
 Schmitz—1878. *Ibid.*, 28, 65.
 Meissl—1879. *Ibid.*, 29, 1034.
 Raffy—1880. *Neue Zeit. Ver. rüb. zuck. Ind.*, 4, 241.
 Reichardt and Bittman—1882. *Zeit. Ver. deut. rüb. zuck. Ind.*, 32, 764.
 Saclis—1884. *Neue Zeit.*, 13, 136.
 Andrews—1889. *Tech. Quart.*, 4, 367.
 Andrews—1889. *Ibid.*, 4, 371.
 Weisberg—1891. *Bull. Assoc. Chim. Suc. et Dist.*, 9, 497.
 Moor—1894. *La Planter*, 20, 409.
 Svoboda—1896. *Zeit. Ver. deut. rüb. zuck. Ind.*, 46, 107.
 Wiley—1896. *J. Am. Chem. Soc.*, 18, 430.
 Pellet—1896. *Bull. Assoc. Chim. Suc. et Dist.*, 14, 131.
 L. de Bruyu and van Ekenstein—1896. *Zeit. rüb. zuck.*, 46, 672.
 Wiley—1899. *J. Am. Chem. Soc.*, 21, 568.
 Wiechmann—1903. *Columbia Sch. of Mines Quart.*, 25.
 Horn—1904. *J. Am. Chem. Soc.*, 26, 186.
 Sawyer—1905. *J. Am. Chem. Soc.*, 26, 1631.

¹ The readings of a quartz plate on an instrument graduated in the standard Ventzke scale averaged 96.02. The same plate read 95.77 on a saccharimeter graduated for true cubic-centimeter flasks. This gives the ratio, 1.0026 : 1, which approximates to the theoretical 1.00234 : 1.

A plate reading, 62.66 on the Ventzke-scale saccharimeter, read 62.45 on the new scale instrument, making the ratio 1.0033 : 1. This is practically the reading corrected for its true sugar value by Schmitz's table, which is 62.43.

The readings of the Ventzke scale instrument were proportional to the quartz rotation.

DETERMINATION OF SUCROSE IN PRESENCE OF OTHER OPTICALLY ACTIVE SUB- STANCES (DOUBLE POLARIZATION)

Fundamental Principles.—In the methods of saccharimetry, previously described, it has been assumed that sucrose is the only optically active substance in the solutions polarized. This is practically true in most commercial polarizations, the error rarely exceeding .2 per cent except in low grade products, where great accuracy in the determination is not so essential. In molasses and sirups, however, the presence of optically active substances other than sucrose may make errors of several per cent in the polarization.

In most molasses and natural cane sirups the principal disturbing optically active substance present is known as "invert sugar." A brief review of the simpler principles of sugar chemistry may be of aid in understanding the nature of invert sugar and the methods of polarization necessary when it is present.

Cane sugar, or sucrose, is one of a class of isomeric sugars known as "saccharoses" or "hexose bioses," from the fact that in chemical classification saccharoses may be considered as anhydride combinations of two molecules of glucose sugar. There are but two other biose sugars of present commercial consequence, *lactose*, or *milk sugar*,

and *maltose*, or *malt sugar*, the latter being only known in commerce as a constituent of many food products. The formula expressing the percentage composition of these saccharoses is $C_{12}H_{22}O_{11}$, or, better expressed from its relation to the glucoses, $(C_6H_{11}O_5)_2O$. Aqueous solutions of bioses in the presence of acids or unorganized ferments, which latter are products of animal and vegetable life and known as "enzymis," absorb an equivalent of water, and are converted into two glucose sugars, *cane sugar* into *dextrose* and *levulose*, *lactose* into *galactose* and *dextrose*, *maltose* into two molecules of *dextrose*. All of these glucoses are isomeric, having the common proportional formula, $C_6H_{12}O_6$, although differing in molecular structure and in many chemical characteristics. This hydration of a saccharose to a glucose sugar, which is known as "hydrolysis," can, therefore, be expressed by the following simple equation:

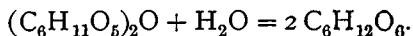

The rapidity of hydrolytic action depends on the chemical energy of the acid or enzym, known as the "hydrolyte," and in the case of acids is greatly augmented by increase of temperature. Many salts and metals also have pronounced hydrolytic action. This action is always "catalytic," as the hydrolyte does not enter into chemical combination with the products formed, as far as is known, but remains unchanged.

Concentrated aqueous sugar solutions, even when shown to be free from acid by ordinary chemical tests, are inverted appreciably at boiling temperature. On this account, in modern sugar manufacture, all concentration is

done in *vacuum* apparatus, so that boiling takes place at a comparatively low temperature (about 50° C.).

In the case of cane sugar hydrolysis, the following structural formulae express the reaction:

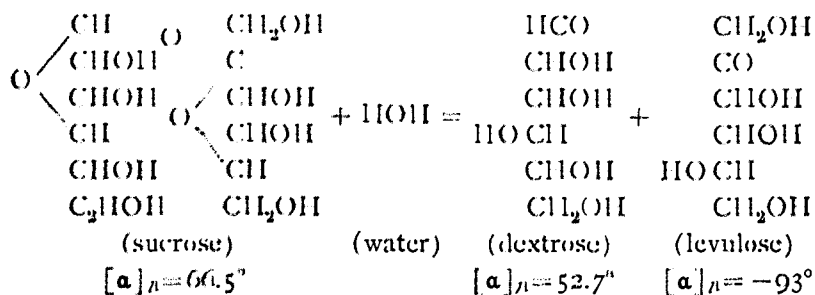

The resulting mixture of the two sugars, dextrose and levulose, is known as "invert sugar," and the hydrolysis is called "inversion," because of the change in specific rotatory power of the mixture from a dextrorotatory value (+) to a levorotatory (-). The specific rotatory power of sucrose is 66.5° at 20° C., that of dextrose 52.7°, and of levulose -93°. The specific rotatory power of the resultant mixture of equal equivalents of these two sugars has become, therefore, about -20°. It will also be evident why these glucose sugars have received the names they bear.

All cane molasses and sirups contain invert sugar, varying from a fraction of a per cent up to 25 per cent or more. This fact may be due in part to the presence of the glucoses in the natural juice,¹ or to inversion of some

¹ Many authorities hold that the glucoses of the cane plant are not present as constituents of invert sugar, as apparently they are optically inactive. This point has been touched upon in the previous chapter, as well as the possible bearing of the action of basic lead acetate on the rotation of invert sugar.

sucrose during the handling of the cane or the manufacturing of the sugar.

Evidently, every equivalent of invert sugar by its left-rotatory effect neutralizes the right-rotatory effect of about one third of the same equivalent of sucrose, and the saccharimeter underreads the true sugar per cent by that amount.

Often in commercial table sirups *right*-rotating substances are present, as in mixtures of "commercial glucose," which has a specific rotation of 130° or more.

Clerget Method of Double Polarization. — Clerget, in 1849, first devised a practical working method¹ for the estimation of cane sugar in the presence of other optically active substances. The method depends on the following principles: (1) Cane sugar, alone of the optically active substances with which it is ordinarily associated in commercial products, undergoes a change affecting its rotatory power when hydrolized with hydrochloric acid, provided that this treatment is carried out under the strictly limiting conditions defined by the process. This change is due to a complete inversion of the cane sugar. (2) A definite weight of cane sugar has its rotation changed by inversion by a constant number of divisions of the saccharimeter at any definite temperature. (3) Hence the amount of *change* in rotation by inversion of a definite weight of any sample is proportional to the cane sugar it contains, and bears a constant ratio to the amount of change in rotation occurring under similar conditions in the same weight of pure sugar. This ratio, therefore, expresses the percentage of sugar in the sample. (4) As the specific rotation of the

¹ *Ann. Chim. Phys.* 26 (3), 185.

levulose formed by the inversion decreases by increase of temperature, the temperature influence must be considered in the calculation. (5) As the amount of change in rotation (the algebraic difference between the polariscope readings before and after inversion) alone is the measure of the cane sugar present, and since cane sugar alone is changed by the process, the rotatory effects of the other optically active substances have no influence on the results. The difference between the two readings and not their magnitudes is the measure.

The normal weight of pure cane sugar reading 100 on the saccharimeter, when inverted by hydrochloric acid under the conditions defined by Clerget, reads -34 at 20° . The total change in the reading is, therefore, 134 divisions. At 0° the difference is 144, and at any temperature t can be expressed as $144 - \frac{t}{2}$. If then the normal weight of sample, polarized under standard commercial conditions, gives a reading of a on the saccharimeter, and a reading b , when inverted and polarized by Clerget's method, the per cent of sugar in the sample will be

$$P = \frac{a - b}{144 - \frac{t}{2}}$$

(If any weight of sample other than the normal is used, multiply by $\frac{N}{w'}$.)

What is practically the original method is as follows: Prepare and polarize the sample by the standard commercial method, but using the half-normal weight if the sample is highly colored. Save the filtrate, prepared for

the direct polarization, for inversion. Take 50 cubic centimeters of this filtrate in a 50-55-cubic-centimeter double marked flask, and add hydrochloric acid of a density of 1.20 to the 55 mark. Mix, and heat gradually to 68°, taking fifteen minutes to reach this temperature. Then cool at once under running water to room temperature. Allow any precipitate of lead chloride to settle out, and polarize in a 2.2-decimeter tube provided with a thermometer,¹ which is read to 0.1° when the solution is polarized. If the ordinary 2-decimeter tube is used, the saccharimeter reading must be increased by 10 per cent, since it has been necessary to increase the volume by that amount, in order to add the necessary amount of acid. A water bath is the usual method of heating the flask, but a double-walled oven heated by boiling xylol, which gives an interior temperature of about 120°, will heat the solution to 68° in, very closely, the right time interval. A water-jacketed oven is too slow, requiring a preliminary heating of the flask to about 45° in a flame.

If the time interval is too short, inversion is not complete, and if the heating is prolonged, or the temperature of 68° exceeded, some levulose is decomposed. The conditions of the inversion must be strictly adhered to. (Note that zero errors of minus readings have corrections in the *opposite sign* to those of plus readings.)

The Clerget method is valuable in many investigations, but, obviously, judgment must be used in its application, for it is clear that such a strong hydrolytic agent as hydrochloric acid will in many cases act upon the rotatory substances present. When "commercial glucose" is

¹ See Fig. 23, p. 93; also footnote, p. 90.

present in large amount, an error amounting to some tenths of a per cent is introduced, owing to the slight hydrolysis of this substance during inversion of the cane sugar.¹ Many prefer the modified German method of Herzfeld,² which is somewhat more complicated, but uses a more dilute acid solution, and is more accurate in samples of low sugar content, as it takes into consideration the change in factor caused by the change in the specific rotation of levulose due to dilution. The German method takes the half-normal weight of sample, which is dissolved in 75 cubic centimeters of water in a 100-cubic-centimeter flask, 5 cubic centimeters of hydrochloric acid of a density of 1.19 added, and the volume made up to the mark, and heated on a water bath to 67-70°, and then kept at that temperature for 5 minutes, the whole heating taking from 7½ to 10 minutes. The factor of change in rotation varies with the concentration, being given in the following table:

GRAMS SUGAR IN 100 CUBIC CENTIMETERS	FACTOR	GRAMS SUGAR IN 100 CUBIC CENTIMETERS	FACTOR	GRAMS SUGAR IN 100 CUBIC CENTIMETERS	FACTOR	GRAMS SUGAR IN 100 CUBIC CENTIMETERS	FACTOR
1	141.85	6	142.18	11	142.52	16	142.86
2	141.91	7	142.25	12	142.59	17	142.93
3	141.98	8	142.32	13	142.66	18	143.00
4	142.05	9	142.39	14	142.73	19	143.07
5	142.12	10	142.46	15	142.79	20	143.13

As the half-normal weight is used, the results are multiplied by 2.

¹ Welser and McPherson, *J. Am. Chem. Soc.*, 17, 319.

² *Zell. Ver. deut. rüb. zuck. Ind.*, 38, 699.

Many modifications of the Clerget method have been suggested with the object of diminishing the possible destructive influence of the acid on the carbohydrates other than sugar. Citric acid has been used as a hydrolyte, and seems especially fitted for investigations of honeys. The destructive action of the acid can be greatly mitigated by carrying out the inversion at ordinary room temperature. The inversion is said to be complete if the Clerget solution is allowed to stand for about eighteen hours at a temperature of about 20°. These modifications, however, have not yet been developed into standard methods.¹

Determination of Sucrose and Raffinose. — In beet molasses and low-grade beet sugars, invert sugar is practically absent, but an optically active substance known as *raffinose*, of marked melassagenic action, is often present to the extent of several per cent. This is a *triose* sugar, being an anhydride combination of three glucose sugars, *dextrose*, *galactose*, and *levulose*. Its specific rotation is 104.5°. By hydrolysis with acid, when the hydrolytic action is mild, raffinose changes so that its rotation becomes about half

¹ Tolman (*J. Am. Chem. Soc.*, 24, 515) states that hydrochloric acid used in inverting solutions already containing invert sugar, as honeys and jams, increases the levorotation. Tolman gives a graphical correction method for eliminating this error, and also states that the variation in the Clerget factor found by Herzfeld is due to this effect of the acid on the rotation and not to differences in sugar concentration. It follows from this that, if this influence is done away with, the Clerget equation becomes, for all conditions of sugar concentration at any given temperature,

$$S = \frac{a - b}{141.85 - 0.5t},$$

and that the invert sugar per cent of solutions containing only sucrose and invert sugar is given by the equation:

$$I = \frac{(a - S) 105.3}{-41.85 + .5t}$$

as great. By more energetic hydrolysis, the rotation changes to one fifth the value. The first stage of the inversion is the formation of levulose and a biose sugar known as *melibiose*. By further hydrolysis, the latter is broken up into *galactose* and *dextrose*. Creydt has calculated formulæ for adapting the Clerget method to the estimation of sucrose and raffinose in beet-sugar products. The readings are taken at 20°, the inversion being carried out according to the German modification of Clerget's process. The formulæ are based on the fact that the change in rotation of a sucrose solution of normal concentration, by inversion, is from 100 to -32.66 at 20° C., while the normal solution of raffinose changes from 185.2 to 94.9 saccharimetric divisions under the same conditions.

The equations are as follows :

$$\text{for sucrose,} \quad S = \frac{.5124 a - b}{.8390};$$

$$\text{for raffinose,} \quad R = \frac{a - S}{1.852};$$

a being the direct reading; b being the reading after inversion, of the normal weight of sample. S and R are the per cents of sucrose and raffinose respectively.

The equations are derived as follows :

$$a = S + 1.852 R; \quad (1)$$

$$b = -.3266 S + .949 R. \quad (2)$$

Multiplying (1) by $\frac{.949}{1.852}$ ($= .5124$), and subtracting (2) from it gives $.5124 a - b = .8390 S$.

The method of Creydt has been modified in a number of ways, more particularly with the object of obtaining better

clarification, as the principal difficulty is with the darkening of the inverted solutions. The use of zinc dust in the inverted solution as a bleaching agent has proved advantageous, and is the feature of several of these modified processes.¹

Speaking in general of double polarization methods, none of them are of universal application; but, if the principles involved are thoroughly understood, they can be applied to great advantage when modified by the intelligent chemist to suit the requirements of the analysis.

¹ See: Lindet, *Sug. Cane*, 1889, 542; Courtonne, *J. des fab. de Suc.*, 1890; Herzfeld, *Zeit. d. V. f. Rübenzucker-Ind.*, 1890, 165; Davoll, *J. Am. Chem. Soc.*, 1903, 1019; Frühling, *Ableit. z. Untersuchung der Rohmaterialien* (etc.) für die Zuckerindustrie, 6th ed., p. 92.

SUGARHOUSE AND REFINERY METHODS

It is not intended to discuss in detail either laboratory methods or processes of sugar manufacture, as there are many excellent treatises exclusively devoted to these matters. The subject will be dealt with very generally, to illustrate the nature of the work required of the sugar chemist, who often is made responsible for the management of the factory work itself. He should seek to master thoroughly the chemical and engineering principles on which the work is based, rather than simply learn details of special methods and processes. Local conditions of one sugarhouse often require radical changes, and the development of a scheme of work differing materially from that in practice elsewhere. In this chapter, certain basic methods only will be enlarged upon, and a scheme of chemical control of a cane-sugar house given as merely suggestive of how such work is done.

In the manufacture of sugar from the *cane*, as a finished product for the consumer, the work is divided between the factories at the plantation, which make a crude product, and the refineries, that purify, decolorize, and recrystallize this "raw sugar." In the United States, practically all the sugar from the cane reaches the consumer through the refinery. *Beet* sugar, to a large extent, is made and refined in the same factory, although large quantities of raw beet sugars are made in Europe specially for export.

Considering first the manufacture of sugar from cane, this can be divided as follows: (1) cultivating and harvesting of the plant, and the transportation of the canes to the factory; (2) extraction of the juice in which the sugar is dissolved from the plant tissues; (3) clarification of the juice from colloidal impurities, especially those which interfere with the evaporation of the juice and consequent crystallization of the sugar; (4) evaporation of the clarified juice to an appropriate density favorable for most effective crystallizing out of the sugar; (5) crystallization processes; (6) separation of the sugar crystals from the mother liquor, known as "molasses"; (7) treatment of the molasses by more or less modified but similar process for the extraction of more sugar, but of lower purity, known as "molasses sugar."

(1) Chemistry has only been applied to a limited extent in cane culture. Although there are the beginnings of much excellent work on fertilizing and soil analysis, especially in Hawaii and Louisiana (one very successful house in Hawaii spending more than \$100,000 in scientifically prepared fertilizers), work on this line is not usually undertaken by the factory chemist, and need not be considered in a treatise on sugar methods. Agricultural chemistry promises to play an important part in the cane-sugar industry of the future.¹

¹ For many centuries sugar cane has been cultivated by propagation from cuttings, and in consequence the plants are sterile as a rule. It is only in recent years, in Java, that seedlings have been successfully cultivated. These have been obtained from plants which have been induced to bear seed by transplanting to the higher mountain levels, where conditions for growth were unfavorable. Seedling farms have now been established in Louisiana, Barbadoes, Cuba, and other cane countries, and are showing much promise for the economic improvement of the cane on the lines so successful in beet culture.

Valuation of the Cane.—Unlike the beet, sugar cane cannot properly be valued by analyses made on laboratory samples, owing to the practically insuperable difficulty of obtaining any small lot of cane which is representative. Different individual canes vary so much that analyses of one or two are of little value. The only satisfactory valuation of the cane is determined by the quality of the juice sampled from the mills themselves during the grinding of a lot of several tons. If, however, a sample of at least a dozen canes is carefully selected so as to represent the actual lot as fairly as can be observed, and the juice from these canes is extracted by a laboratory three-roller mill, such as are now specially made for the purpose, the mill being adjusted and the crushing made so as to give an extraction approximating that in actual practice in the factory, the analyses will agree very well with those of the mill juice from the sugarhouse. This will require running the sample canes three or more times through the experimental mill. Such preliminary laboratory tests are important in many cases, as where it is necessary to examine the standing cane from the fields to ascertain its fitness for grinding, for instance; but in factory control the test of the juice actually obtained in the sugarhouse is a better valuation, and the one usually relied on.

The cane coming to the mill is weighed in the carts or cars in which it is brought. To this weight all yields and losses are usually referred as percentages, although a better basis of reference is the *weight of sugar in the juice actually extracted* or the calculated *weight of sugar in the cane*. This latter weight, however, is somewhat approximate, as it is practically impossible to obtain directly an accurate

determination of the fibre in the cane, which is a necessary datum for this calculation, owing to the difficulty already alluded to of obtaining a representative laboratory sample. It should be explained here that, for convenience in calculation, the cane is arbitrarily divided into two parts, *juice* and *fibre*: the juice being that part which can be extracted by exhaustive treatment with water; the fibre, the residue after drying, — in ripe tropical canes about 11 per cent. It consists of pentosan bodies and other insoluble matter besides the cellulose, which is its chief constituent.

(2) **The Juice Extraction.** — In the best modern houses, the cane passes through three mills¹ of three rollers each, so that it actually undergoes six crushings. Sometimes the

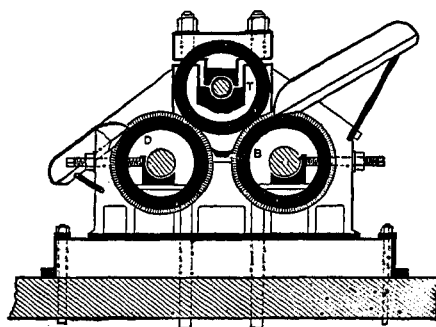

FIG. 25.—SECTION OF CANE MILL.
(From Thorp's "Outlines of Industrial Chemistry.")

three mills are combined in one machine. The crushed mass coming from the mill is called "bagasse," and should be a friable mass of fibre barely moist to the touch, although actually containing about 50 per cent of moisture. The bagasse

goes to the boiler furnaces as fuel, and with it, of course, a certain amount of sugar in the juice not completely extracted. This is the first inevitable loss in manufacture.

¹ Extraction by diffusion is not discussed here, as in most cane-growing countries this method of juice extraction is impracticable, owing to local conditions. Sometimes the cane is passed through a "crusher" or "shredder," to more thoroughly disintegrate it before milling.

The juice from the mills is either weighed directly by automatic weighing machines, or its weight determined, as is usual, by calculation from its *density*, obtained by the "Brix spindle" (shortly to be described), and its *volume*, measured in calibrated tanks, usually the clarifiers. The *weight of juice as a percentage of the weight of cane ground* is known as the "extraction" of the mills.

Ripe cane is treated with hot water, which is commonly applied to the bagasse sheet passing between the second and third mills. This is known as "maceration," and considerably increases the extraction. The amount of water added varies, according to circumstances, from 5 to 20 per cent, or more, of the weight of the juice, and necessarily complicates the extraction calculation, as will be explained later.

The extraction of a modern sugarhouse varies from 72 to 80 per cent, or more, according to quality of the cane and manner of milling. Often the third mill juice, which only amounts to a few per cent of the total, is treated separately, owing to its greater impurity; and in some factories lime is added to the bagasse in maceration. These and other modifications of process require corresponding modifications in the chemical control, which must be made by the chemist to suit the peculiar conditions.

The juice coming from the mills is a thin, opaque sirup, usually of a dark olive color, the tint varying considerably according to the condition of the cane and the soil on which it is grown. Beside 15 to 20 per cent of sucrose, it contains about .4 per cent of albuminoids, waxy matter, and other plant extractives. Small quantities of glucose sugars are also present, in ripe cane less than .3 per cent, and an insignificant amount of mineral matter.

The determinations on the juice important for factory control are the sugar per cent and the "quotient of purity."

Quotient of Purity. — As, in the different steps of sugar manufacture, the *water content* of the product in process is constantly changing, a simple polarization giving the per cent of sugar on the weight of sample is of little value as a measure of the purity of the product, unless made on the *water-free* (anhydrous) substance. In the necessarily rapid determinations of factory control it is impracticable to dry each sample before polarizing. If, however, the *per cent of total solids* in the sample can be conveniently obtained, *the percentage ratio of the sugar per cent of the sample to this value will be the per cent of sugar in the anhydrous substance.* As this ratio is independent of the water content, the determinations of total solids and sugar percentages can be made on solutions of the sample at any convenient concentration, the only condition being that both tests are referred to the same concentration.

This ratio, giving the per cent of sugar in the anhydrous substance of the sample, is known as its "quotient of purity" ("purity"), and can be expressed in the equation :

$$Q = \frac{100P}{S},$$

where P is the polarization of the solution of

the product at any convenient concentration, and S is the per cent of total solids at the same concentration.

Determination of Total Solids. — The *density* of the solution gives a rapid means of determining the per cent of total solids with an approximation sufficiently close for the purpose, the assumption being made that the impurities ("non-sugars") in the juice affect the density in the same

proportion as would an equivalent weight of dissolved sugar.

Hydrometers of great precision are specially made for sugar testing, which are graduated to give at a standard temperature (17.5° C.) a direct reading of the per cent of sugar in a pure solution. In solutions of the impure products of cane-sugar manufacture, such a hydrometer gives readings expressing the per cent of total solids very closely.

These hydrometers are known as "Brix spindles" or, sometimes, "Balling spindles." Balling was the first to calculate the tables on which their graduation depends. Brix revised them later, his values being practically identical with those of Balling, except at the higher concentrations. The better class of Brix spindles have a thermometer attached, and often this thermometer is graduated to give by direct reading the correction for the Brix reading at any temperature other than at 17.5°. These thermometer graduations for the Brix temperature corrections are usually inexact, because the makers commonly make the assumption that the coefficient of expansion of the solution is the same as that of pure water, whereas it is perceptibly greater, even at moderate concentrations. If such graduations are placed on the thermometer, it should only be done on spindles having a range of scale of 10° or less, and the corrections should be calculated for a concentration corresponding to the *middle* reading of the scale of the spindle.

Table No. 2 (see Appendix) should be used for making these corrections in accurate work.

Reading of Brix Spindles.— Brix spindles, like all correctly made hydrometers, should be read along a line lying

in the plane of the surface of the liquid (shown by line *a*, Figure 26), and not at the line of contact of the liquid with the stem (*b*), this line being raised above the surface by the capillary attraction of the liquid, to a varying extent depending on the viscosity of the liquid.

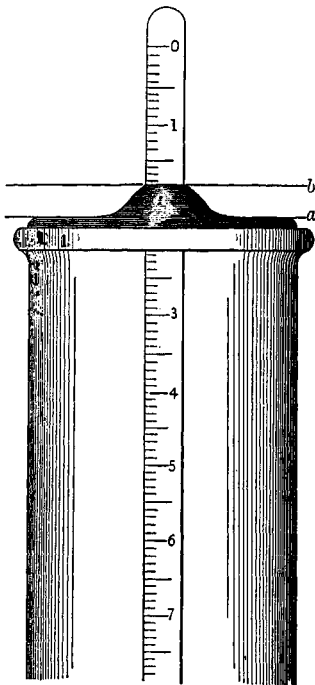

FIG. 26. — ILLUSTRATING METHOD OF READING A HYDROMETER.

Some of the Brix spindles made for commercial work are graduated for 15° C. or 60° F. Some sugar refiners use the Fahrenheit scale on their Brix spindles, the standard being practically the same as 17.5° C. (63.5°).

Determination of Sugar in Solutions. — Owing to the inconvenience and inaccuracy of determining weights of liquids by a balance, methods have been devised for polarizing sugar solutions without the necessity of weighing. One way is by use of the "sucrose pipette," which is a pipette of the ordinary shape but graduated on the upper

stem with a series of marks corresponding to degrees Brix. If the pipette is filled to the mark corresponding to the reading of the solution given by a Brix spindle at the temperature of observation, it will deliver the normal weight of 26.048 grams of the solution. These pipettes, being used for juice testing, are usually made to deliver

double the normal weight, and so reduce the error of the small saccharimetric readings correspondingly.

The method of determining the per cent of sugar in a solution, generally used in refinery practice, depends on the following principles :

As the normal weight of pure sugar, dissolved in 100 cubic centimeters of solution, when polarized in a 2-decimeter tube, gives a saccharimetric reading of 100, then : any saccharimetric reading (R) of any solution containing sugar (sucrose) as the only optically active substance, and polarized in a 2-decimeter tube, shows that $\frac{R}{100}$ of the normal weight of sugar must be dissolved in 100 cubic centimeters of the solution. If this value is divided by the density of the solution,¹ the quotient will give the per cent of sugar in the solution.

Hence, expressing the normal weight by N , and the density by d , the sugar per cent of any solution (S), when its saccharimeter reading given by a tube of standard length (2-decimeter) is known, can be found by the following equation : $S = \frac{RN}{100d}$.

In practical work, as most solutions to which this method is applied, such as cane juices and molasses, have to be clarified before they can be polarized, it is necessary in such cases to allow for the change in concentration of the solution resulting from the addition of the clarifying agent. This is most conveniently done by the double-marked flask, such as has been described under the Clerget method of double polarization. The flasks customarily used are graduated at 100 and 110 cubic centimeters, although as

¹ See the equations expressing concentration of solutions on pp. 12 and 13.

the function of the flask is to determine the ratio of dilution, it is immaterial whether this size or the 50-55 flask is used, the errors of observation of the reading of the smaller volume, being well within the other errors of analysis. In such cases, obviously, the equation given must be multiplied by $\frac{11}{10}$. Tables allowing for the increase of $\frac{1}{10}$ in the original concentration, and based on the equation given above, have been designed by Schmitz for the use of sugar chemists.¹ These tables give the per cent of sugar directly when the saccharimetric and Brix readings are known, the Brix reading in this case being used as an expression of the density in the calculations. The calculations of the table are corrected for slight changes in the specific rotation of sucrose at low concentrations in very dilute solutions. This affects the third significant figure, hence the table differs from the results obtained by the equation only by that amount.

Method of Determination of Quotient of Purity.—The ordinary method of quotient of purity determination is as follows: If the sample is a cane juice, strain out any particles of bagasse by passing the juice through fine copper gauze, and allow it to stand till all the air bubbles have escaped. The Brix reading is then taken. If the sample is a molasses or similar product, it is diluted to about 15° Brix before taking the exact Brix reading.² All Brix readings must be corrected, of course, to standard temperature.

The Brix reading expresses the per cent of total solids in the solution, and from the same reading the density can be determined by a comparison table (see Table No. 1 in

¹ See Table No. 3 in Appendix.

² See Hartmann, *Hawaiian Planter's Monthly*, 22 (1903), 383.

Appendix). A double-marked flask is now filled to the *lower* mark with the solution, the requisite amount of basic lead acetate added to clarify, and the solution made up to the upper mark and thoroughly shaken. The solution is then filtered and polarized in the ordinary manner.

The refiners use their own "exponent" books, which are arranged in tables to give the quotient ("exponent") without calculation for known Brix and saccharimeter readings, the sugar per cents of the liquors in process being usually unnecessary for their records.

Weisberg's Method of determining Total Solids.¹—Another ingenious method of determining the total solids without the use of the Brix spindle, only applicable to molasses and other concentrated products denser than 78° Brix, has been devised by Weisberg, and is in practical use in some European houses. It is based on the fact that, according to the original Ventzke standard, by which the saccharimeter is graduated, a solution of the normal weight (26.048 grams) of pure sugar dissolved in 100 Mohr cubic centimeters has a density of 1.1000 at 17.5° C. referred to water at 17.5° as unity. As in the Brix method, it also makes the assumption that the non-sugars have the same density factors as the dissolved sugar.

If 26.048 grams of the sample are dissolved in 100 cubic centimeters of solution, the significant figures of the density value, less 1.0000, will express the per cent of total solids in the sample. For instance, if the density is 1.0846, the *original sample* contains 84.6 per cent solids. The saccharimeter reading, of course, gives the per cent of sugar

¹ For other methods of determining quotient of purity, see Wiechmann, "Sugar Analysis."

in the sample, as the solution is a normal one for the saccharimeter.

Quotient of purity determinations are of great value to the manufacturer as giving rapid comparative figures for determining the efficiency of the different processes. To the refiner, particularly, they are indispensable as a basis for planning the most economical working of raw material, often of the most variable quality, into a uniform refined product. Too much importance, however, should not be attached to exact numerical value expressed by the purity figures, as, owing to the diverse nature of the "non-sugars" under different circumstances, products of the same "purity" may work up quite differently.

Other tests made on cane juice, of more or less value for chemical control of the factory, are for acidity and glucose sugars. Acidity tests are usually expressed in terms of decinormal sodium hydrate or lime to neutralize, using phenolphthalein as an indicator. The glucose test is not considered so important as formerly, when these sugars were supposed to have a much greater effect than they do have upon the crystallization of the sucrose. As a matter of fact, the glucose sugars in themselves have little harmful effect, but their amount in juice from fresh cane is to a large extent indicative of its condition. Unripe cane always contains a larger proportion of glucose, which is associated with albuminoid (pectenoid?) substances, usually termed "gum." These greatly increase the viscosity of the liquors in process, retarding evaporation and interfering with crystallization. They are only partially removed by the ordinary processes of clarification. The glucoses are the indicator rather than the dis-

turbing cause, and as one test for unripe cane this determination has some value.¹ As any destruction of sucrose by inversion due to ferments or other cause produces glucose sugars, any marked increase in the "glucose ratio" (the ratio of glucose to sucrose) in the products in process is evidence of inversion; but as, in the majority of cases, these glucose sugars are destroyed to considerable extent during the processes of clarification and in the "meladuras" (evaporated sirups), the values of the glucose ratio must be interpreted with considerable caution. The methods of determining glucose sugars will be discussed later.

Determination of Extraction when the Juice is diluted by Maceration.—When the juice is diluted by maceration water, the determination of the amount extracted at its original concentration is somewhat complicated. In this case it is necessary to determine the Brix of the juice from the mill before it is macerated, and also the Brix of a sample of the total amount of completely mixed and diluted juice. The per cent of maceration water will be given by the following equation: $P = \frac{B_1 - B_2}{B_1}$, where P is the per cent of maceration water in the juice, B_1 is the Brix of the normal juice, B_2 the Brix of the diluted juice. From these data the weight of the normal juice can be readily obtained.²

¹ Ripe cane, if old and soured, of course, contains glucoses from the inversion. Such cane, if not absolutely rotten, "works" easily, as the "gum" is absent, although it gives a poor yield and much molasses.

² The quality of the juice from the different mills varies somewhat, that from the later crushings having more impurities. Maceration also lowers the purity of the juice. This small change in quality of the juice does not appreciably affect the calculation given here.

Determinations on the Bagasse. — The per cent of sugar in the bagasse is sometimes determined as a check on the extraction figures, but the most useful datum is the *fibre content*, as this can be utilized to estimate the fibre in the cane by calculation from the extraction. The extraction being known, the per cent of fibre in the bagasse can be referred to the cane itself. The great difficulty in this determination is in the sampling, as not only does the bagasse vary in its nature, but it dries very rapidly in a small sample. The only proper sample is one of at least 200 grams. The bagasse should be collected in a covered box, in which it should be weighed without removal to avoid error from evaporation. The weighed sample, if not well shredded, should be picked to pieces and then placed in a gauze basket and thoroughly washed, preferably in warm soft water, till the washings no longer react for sugar. The residue, dried at 105° C., is taken as the "fibre."

Juice. — The *juice* should be sampled at least once an hour, the samples either being tested at once or measured portions put in a graduated bottle in which has been placed a few drops of mercuric chloride solution to avoid fermentation. This general sample is tested at regular intervals, three or four times in twenty-four hours. As lots of cane from different plantations are often bought at a price based upon the quality of the juice extracted by the mill, individual samples of juice are also taken from the mills during the grinding of such lots and tested separately.

Conditions, of course, will considerably modify the chemical control methods, and many other interesting and valuable tests can be made on the juice, such as those which throw light on the nature of the colloidal non-sugars and

their removal, the viscosity of the juices, etc. Such work will depend on the facilities at the disposal of the chemist.

(3) The juice from the mills next goes to the clarifiers, either directly or after a previous mixture with the precipitant, and in many cases a preliminary heating by the waste heat from other factory processes, which is thus economized. Clarification in raw cane-sugar manufacture is a crude process at best,¹ and is only designed to remove those impurities which have influence in preventing crystallization and evaporation. These impurities are in the main of an albuminoid nature, the composition of which is little understood. They seem to be of an amino or amido constitution, related to glycocoll or asparagine, and xanthin bases. They exist in the juice in a "colloidal" or gelatinous condition, and consequently have to be precipitated before they can be removed by settling or filtration. There is also a waxy substance from the rind of the cane. By bringing the juice to practically the neutral point with fresh *quicklime* and heating to about 185° F. (85° C.), about 50 per cent of the total albuminoids are precipitated, which is sufficient for raw-sugar manufacture. The special clarification or "defecation process," as usually carried out, consists in heating the limed juice in shallow tanks ("defecators") provided with a relatively large heating surface so as to produce rapid enough convection to throw the precipitated albuminoids and wax to the surface, where they remain as a thick scum or

¹ A certain amount of white sugar is made in all sugar countries for local consumption. This sugar, as a rule, is made from liquors which have undergone a second filtration and bleaching with sulphur dioxide, and is carefully washed in the centrifugal machines, steam being used to make dry crystals.

“blanket.” After the clarified juice is allowed to stand till the small amount of settlings deposit, the clarified juice, which in an ordinary test tube looked at transversely usually appears as a clear yellowish green sirup, is decanted into tanks for further settling before going to the evaporators. The amount of lime required for defecation varies considerably with its quality and the condition of the juice, for fresh ripe cane juice, averaging about 6 pounds per 1000 gallons. It may vary greatly from this figure. The point of proper defecation is practically the neutral point. Usually, but *not* necessarily, the decanted juice shows a faint alkalinity (.002 to .005 with phenolphthalein). The exact point is much better shown by the appearance of the precipitated albuminoids and the clarified liquor than by any of the usual indicators. Proper defecation is shown by the appearance of a well-defined coagulation, the coagulated matter being flocculent and settling slowly, leaving a practically clear sirup. Overlimed juice is dark colored, and the precipitate settles rapidly. In underlimed juice the liquor is milky from incomplete coagulation. The odors also are characteristic to an expert. Overlimed juices make deposits on the coils of evaporating apparatus, and also produce slimy humus products from the decomposition of the glucose sugars, which interfere in the purging in the centrifugals, especially in second sugars. Overliming is a common error, but the consequences of underliming are more obvious. Often loam or clay from canes which have been beaten down by winds or rains give a turbidity which remains in the decanted juice and is apt to deceive the inexperienced. This does little harm if not excessive, and can in the main

be removed at the mills by suitable settling devices in the juice canals.

In the *Deming process* the continually passing juice is heated in a sort of digester under low steam pressure, the heat of the clarified juice being economized by being transferred back to the entering cold juice, on the principle of the surface condenser. The coagulated albuminoids, which are said to be more perfectly separated, have a tendency to settle, and are, when the process works properly, removed from the bottoms of settling tanks.

In the older methods of defecation, the scums on the surface of the defecators were swept off into draining boxes. In modern houses, they are passed through filter presses. The proportion of juice which passes through the filter presses varies in different sugarhouses, but when the defecation and decantation are properly carried out, does not exceed 15 per cent, even with poor juices. The scums before passing through the presses are cooked with more lime, as this gives a harder press cake, and the slightly alkaline juices neutralize the acidity which would otherwise result from the enormous cooling and aërating surfaces of the presses with their complicated spaces in which fermentation takes place at times in spite of care. The filter-press liquors are slightly darker in color, more alkaline, and of lower purity than the decanted juice.

Obviously, the second necessary loss in the house comes from the sugar of the juice left in the press cake, and is determined by polarizing a representative sample of the fresh cake, allowance being made in the weight of sample taken, for the volume occupied in the flask by the insoluble matter in the cake. A few drops of acetic acid are added

by some to break up any possible calcium succrate which might be formed if the liming is excessive. The normal weight for filter cake, as usually taken, is 25.00 grams, which is most conveniently made up to a volume of 200 cubic centimeters, the saccharimeter reading, of course, being multiplied by 2.

The total weight of cake is taken as it is removed from the presses, or can be approximated with sufficient accuracy, by calculation from the number of presses in use, by multiplying by the average weight of cake per press determined occasionally.

Other clarification and filtration processes are in use. Often a secondary filtration is given the juice after clarification, by "mechanical," or "sand filters." If the juice is properly defecated, this secondary filtration is quite unnecessary in raw sugar manufacture.

The loss of sugar in the filter cake, unwashed, usually lies between .10 per cent and .15 per cent of the weight of cane.

(4) The clarified juice from the settlers goes to the multiple-effect evaporators, where it is concentrated to about 35 per cent of its volume, making a sirup known as "meladura," which is ready for crystallizing in the vacuum pans.

The density at which this sirup is concentrated depends on its purity, it being difficult to crystallize in the vacuum pan from impure meladuras when very concentrated. Very pure meladuras can be worked up from a density of 30° "Beaumé"¹ (54.3° Brix), but meladuras from unripe juices

¹ There are twenty or more different Beaumé scales in existence. The original was made by Beaumé by taking water at 12.5° C. as zero, and a 10

work much better at considerably lower density. At the same time, it must be understood that evaporation is done far more economically in the multiple-effect apparatus than in the vacuum pan.

Meladura is usually stored in a series of settling tanks of small capacity, so that they can be frequently emptied and cleaned without interfering with the work of the house. At least once a week every tank should be thoroughly cleaned and whitewashed, the settlings being run off into the first molasses (*not* into the juice scums).

In the more primitive processes of sugar manufacture, which are still extant in some places, making what are known as "muscovado" or "open kettle" sugars, the clarification and evaporation to the crystallizing point are carried on in a series of hemispherical kettles built into a brick furnace. The lime is added in the first kettle, where the main defecation occurs, and the juice as it evaporates is ladled from one kettle to the next till the more concentrated sirup is collected in the last. The scums from the defecation are swept in the opposite direction, and finally from the surface of the liquor in the first kettle into a draining box.

The tests of the meladura useful for chemical control are, its density, its purity, and its alkalinity. The meladura should always react *faintly* alkaline. If it reacts acid from any cause, milk of lime should be stirred in.

(5) The crystallization of the sugar from the meladura

per cent solution of common salt as 10. The scale which is in universal use in the sugar industry is that of Gerlach, and is somewhat modified from the original Beaumé. This Beaumé spindle is exclusively used by workmen in the sugarhouse.

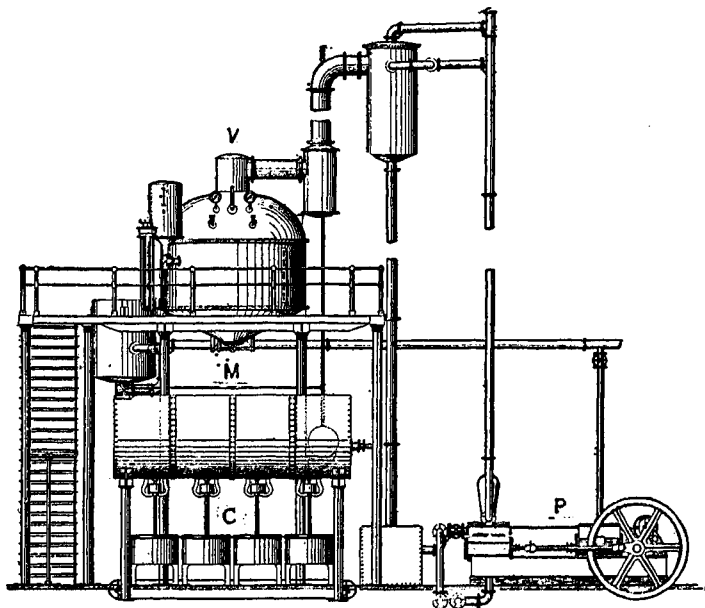

FIG. 27.—INSTALLATION OF VACUUM PAN AND CENTRIFUGALS IN A SUGARHOUSE.

V. Vacuum pan.
C. Centrifugals.

M. Mixer.
P. Vacuum and condenser pumps.

(From an old drawing.)

by the vacuum pan can be divided into three stages: (*A*) the evaporation of the meladura to the point of sugar saturation; (*B*) the formation of the crystals, or "graining"; (*C*) the building up of the crystals to the required size.

In the first stage, the pan is simply working as an ordinary evaporator, the special skill of the pan man being required in one particular, the amount of "charge." This must be so regulated that the meladura, concentrated to the saturation point, will have the requisite volume to allow for the growth of sufficient crystals to just fill the pan full when the sugar is finished. This, obviously, is a matter requiring considerable experience, and is conditioned on the quality of the juice, as well as the size of the crystals required, and the polarization.

The starting of the crystallization is also a matter requiring much skill and experience. As soon as the first "sparks" are visible in the "proof," taken out of the pan at frequent intervals, the temperatures must be carefully regulated, usually by manipulating the condensing apparatus. The "drinks" of meladura taken into the pan must be as carefully graduated so as to regulate the amount of the crystals which form, for on this will depend to a large extent the quantity of finished sugar of the required polarization, as well as the size of the crystals themselves. If the juice be of poor quality, the meladura used to control the crystallization at this point must be less dense, and the temperature raised, to prevent the "grain" forming too rapidly. After the requisite crystal foundation is established in the "charge," subsequent additions of meladura must be skillfully made during the rest of the process, so that the crystal growth will proceed regularly and con-

tinuously, with the minimum production of "false" or "second grain." This latter is caused by the separation of sugar in fine floury crystals, independently of the original foundation grain, and cannot be avoided absolutely, although practically evaded by skillful pan men. The second grain, if the crystals are too large to pass the screens of the centrifugal machines, makes "purging" harder, and reduces the polarization of the sugar, owing to the greater absorption (capillarity) due to the unequally sized grains packing more closely. If the second grain is fine enough to pass the screens, it goes into the molasses, and so reduces the yield of the first sugar.

Skill engendered of long experience and familiarity with the working of his pan are essential qualifications of a first-class sugar boiler. Such men, in raw-sugar work, command high pay and have much responsibility. An unskillful man may cause a loss of hundreds of dollars a week.

When the sugar is finished, the pan is filled with a stiff pasty mass of crystals and molasses in about the proportion of 65 per cent of sugar to 35 per cent of molasses. This is known as "massecuite."

(6) The steam being turned off and the vacuum broken, the massecuite is discharged into the "mixer," where it is kept slowly stirred till it has all been passed through the "centrifugal" machines, — sieves which revolve at a speed of a thousand revolutions or more per minute, by which the molasses is removed, leaving a moist mass of brown sugar crystals. The sugar after being cooled by fans is put into bags usually holding about 300 pounds.¹

In the chemical control, purity and density tests of the

¹ Hawaiian practice: 125 pounds.

first massecuite are useful, but are not often made part of the daily routine.

The polarization of each "strike" of first sugar, as well as the weight obtained, is important. Often it is necessary to follow the working of the centrifugal machines during the running, to regulate the time necessary for purging, and the amount of "charge" to turn out the requisite quality of sugar. This is done by making polarizations of samples at once as soon as the purging begins.

The usual conditions require the sugar to be turned out as near 96 per cent as possible. Sometimes the sugar is allowed to stand for some hours in "coolers," or wagons, before purging. This is not commonly done.

One possible source of loss in vacuum apparatus is from what is known as "entrainment," which is the carrying off of sirup mechanically in the current of vapors passing away from the apparatus. The sirup, owing to its viscosity,

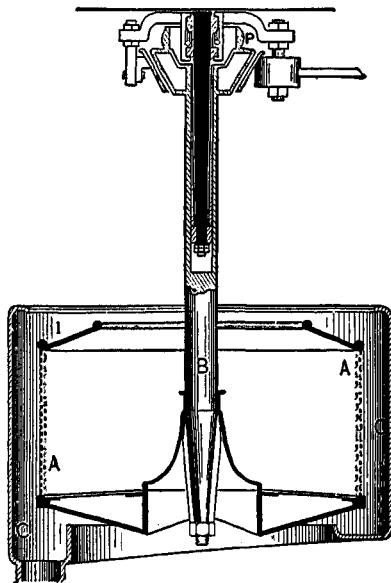

FIG. 28.—SECTION OF WESTON CENTRIFUGAL MACHINE.

- A. Sieve in side of revolving "basket" which retains the sugar.
- B. Shaft of basket on which slides bell which closes opening for discharging sugar.
- C. Casing in which collects the molasses discharged through the sieves.

(From Thorp's "Outlines of Industrial Chemistry.")

escapes, it is said, in vesicles analogous to minute soap bubbles.

Modern apparatus is so well designed that entrainment is reduced to a minimum which is practically negligible in good work. Occasionally, steam coils in the pan may spring a leak. If the leak is a small one, it may not affect the working of the pan, but when such coils are shut off, the vacuum formed in the coils causes sirup to enter them. As the condensation water from the coils is used for boiler feed, the sugar may do much damage by collecting in the boilers and causing them to foam. The "tailpipes" of all vacuum-pan coils should be provided with test cocks so that the "returns" can be frequently examined for sugar. The polariscope is hardly sensitive enough to show the small quantity of sugar which it is necessary to detect in some cases, chemical methods being more applicable. Indeed, the color and odor of the returns is sufficiently conclusive of a leak. The returns from the steam chambers of the multiple-effect evaporators are also used for boiler feed, so that any entrainment other than from the last effect will also affect the "sweet waters" (as they are erroneously called), and do mischief to the boilers.

The Brix, polarization, and quotient of purity are taken of a representative sample of first molasses from every "strike" of sugar.¹

(7) The methods for further extraction of the 50 per cent or more of sugar contained in the molasses vary much in

¹ The most accurate way of determining the total solids ("Brix") of a molasses is to dilute by *weight*. For instance, add to 100 grams of the sample sufficient water to make the solution weigh 500 grams. Five times the Brix reading of the solution will give the total solids in the molasses in this case.

different places. Usually, the molasses is diluted somewhat, heated to dissolve any "grain" that may be present, and is concentrated in the pan to the graining point, but not far enough to have crystallization actually take place.

It is then run into tank wagons, or into crystallizers, where it is allowed to remain till crystallization is complete, the time being generally from five days to a week. This is known as "boiling blank." The massecuite is then purged with centrifugals, giving "second sugar." Usually the heat is regulated by steam pipes in the "hot room" where the wagons are stored, so as to retard the cooling and allow gradual growth of the crystals.

The "crystallizer" is a modern apparatus for controlling the conditions of crystallization more effectively, requiring less skill in handling to obtain a uniform product than the wagon methods. In its ordinary form, the crystallizer is a large horizontal cylinder, holding twenty-five tons or more, provided with a slowly moving stirring apparatus, and arrangements for heating or cooling the contents. The massecuite is run into the crystallizer, where it is allowed to stand for a number of hours, till the crystals have begun to appear, and then the mass is occasionally (very slowly) stirred to bring fresh molasses in contact with the crystals. The temperature is regulated accordingly as the crystallization progresses, being also conditioned on local circumstances. Sometimes, with rich molasses, the graining is made in the pan as in the case of first sugar, or the grain is started with meladura, or sugar is actually put in the pan for a grain foundation.

Other methods are designed to utilize the first molasses directly in the formation of first sugar. In one, the water

of the molasses of the first massecuite is practically all boiled away, and the hot molasses of the previous "strike" is injected at the right moment, thinning the whole mass sufficiently to allow it to run out of the pan. Sugar is crystallized out in this way, and the molasses is lowered in purity. In another method the molasses is thinned to the consistency of meladura, and an amount, dependent on its purity, is used to build up the grain during the latter stages of the boiling of the first sugar. Only a part of the total first molasses can be utilized in this way, the rest being made into "second sugar."

The second sugars are polarized, and the tests for Brix and purity, as well as the polarization, made on the second molasses. This latter is often worked up for a third sugar, but if the processes of extraction of the two sugars are skillfully carried out, most raw juices will not pay for a third working. A good yield of "thirds" does not by any means always indicate good work. The second sugars are often remelted to a sirup, and worked up with meladura into first sugars. In some cases the sugar itself is put into the first massecuite in the mixer.

The chemical control of a raw-sugar house carrying on the process in the general manner outlined is for two objects: (1) the guidance of the daily routine of the house; (2) an accurate estimation of the total yields and losses during a definite period of running.

As the sugarhouse is running continuously, night and day, most of the material in process is distributed through the house, and constantly undergoing such change that any daily estimate of the yields and losses during the actual running is only an approximation too rough to be of value

in calculating the efficiency of the work. The weight of the cane and that of the juice, giving the extraction, can be estimated with reasonable accuracy, but, as most houses are arranged, this is the only daily calculation which is of value as showing the total actual work accomplished. Usually it is necessary to shut down the house at least once a week for half a day or more for overhauling the machinery, and particularly for cleaning the copper heating surfaces of the evaporating and clarifying apparatus. The copper becomes badly fouled by the end of a week from the deposits from the juice, necessitating a thorough cleaning, usually given by boiling out with very dilute hydrochloric acid.

At the time of shutting down, all cane and thin juices are worked up, and usually all, or most, of the meladura. The first sugars are worked up, except what may be represented in any meladura (and in some cases in the first molasses, when this is worked into the first boilings directly). Hence, pans and all evaporating and clarifying apparatus are empty. There are usually many tons of second sugars in process which must be estimated before the work of the house can be ascertained. All the sugar represented in this "stock in process" is carefully calculated, first, by determining the weight of the different products from their densities and the volume of the containers, these latter being among the constants calculated once for all, and tabulated in the laboratory records. From the purity figures of the first molasses and meladura, similar calculation constants can be established, by which the yield of sugars from the stock in process can be rapidly estimated.

From the amount of first and second sugars shown to be in process by the figures of the "stock in process" book, must be deducted, obviously, the corresponding sugars held in process at the end of the previous working period.

In the estimation of the work of a sugarhouse during the running period, from one clean-up to the next, the scheme of calculation would be somewhat as follows:

STOCK WORKED UP

A. Weight of cane ground. From the weighers' books.

B. Weight of juice extracted.

Weighed directly by automatic scales, or determined from number of defecators of known volume, in gallons, which can be expressed in pounds by equivalents calculated on the Brix, at the temperature at time of gauging. (Maceration water deducted by calculation, based on Brix determinations of the normal and diluted juice.)

C. Fibre in the bagasse.

D. Weight of sugar in the press cake.

Obtained by polarization and weight of total cake; the latter by actual weighing, or estimated from number of presses filled and calculated weight of cake per press.

E. Weight of first sugar manufactured.¹ From the weighers' books.

F. Weight of second sugar manufactured. From the weighers' books.

¹If the second sugars are remelted and worked up into first sugars, allowance must be made accordingly.

STOCK IN PROCESS

G. Weight of first and second sugar represented in the meladura in process.

Calculated from the number of gallons in tanks, by equivalents per gallon, based on the purity and Brix.

H. Weight of second sugar represented in first molasses.

Calculated from gallons in tanks, by equivalents, based on the Brix and purity of the molasses.

I. Weight of second sugar represented in the second massecuites, in cars and crystallizers.

Calculated from weight in pounds of massecuites, estimated from volumes of containers and Brix, using purity equivalents.

J. Weight of sugar in second molasses.

Calculated from polarizations and first molasses and second massecuites in process.

From the above data are obtained the following, which are expressed either as percentages of sugar on *the weight of cane*, or on the *weight of sugar in the cane*:

- (1) The extraction of the juice.
- (2) The sugar in the cane.
- (3) The sugar received into the boiling house.
- (4) The loss of sugar in the bagasse.
- (5) The loss of sugar in the filter-press cake.
- (6) The yield of first sugar.
- (7) The yield of second sugar.
- (8) The loss of sugar in the second molasses.

The sum of the percentages of yields and losses will not balance the per cent of sugar in the cane by .2-.4 per cent of the weight of the cane. This difference is known

as "undetermined loss," and may be possibly due to "chemical losses," in which sugar is destroyed by inversion or other chemical change in

- (a) Clarifying.
- (b) Evaporating.
- (c) Crystallizing.
- (d) From fermentation in tanks and other apparatus.
- (e) Chemical changes in second massecuites from ferments, molds, or obscure chemical changes.

Or "mechanical losses" from

- (f) Entrainment.
- (g) Leaks and spills from accidents.
- (h) Losses in cleaning out apparatus.

The destruction of sugar in process is by no means well understood. Refinery experiments in Europe have shown that in every pan boiling ("strike") about .4 per cent of the sugar is destroyed. Undoubtedly some chemical loss occurs in the evaporating and clarifying processes. To this may be added "apparent" loss due to errors inherent in polariscope measurement, which, according to some authorities, amount to some tenths of a per cent.

Fermentation losses in any part of the house under ordinary conditions of work are inexcusable. Absolute cleanliness and a free use of lime and steam in spots liable to infection should eliminate this trouble in a properly designed sugarhouse.¹

¹In Louisiana sugarhouses certain bacterial organisms, notably *leuconostoc mesenteroides*, have destroyed much wagon sugar, transforming the sucrose into *dextran*, a pentose gum which is a close analogue of dextrin.

In Porto Rico, the writer has observed *leuconostoc* in one or two instances in the raw juice tanks, where, in a few hours, it has grown enough to completely clog the juice pumps. The growth was easily removed and did not return. *Leuconostoc* seems to be a characteristic of unripe canes.

Some mechanical losses will occur, necessarily in cleaning, but they can be largely controlled by good management, provided the house is working uniformly. Frequent stoppages necessarily increase these losses.

All tanks and other containers should be *numbered*, and an accurate record of their volumes be kept. Tank volumes are most easily figured by measuring in gallons per inch of depth of liquor. The total amount of liquor in a tank can then be quickly calculated by gauging with a measuring rod and multiplying by the factor giving gallons per inch for that tank. Defecators and other apparatus with irregular bottoms or containing coils can be conveniently calibrated by filling the irregular section with water, and dropping the contents into a tank of known capacity.

The above rough outline of a scheme of control for the yields and losses of a West Indian sugarhouse is only suggestive of the way such work is done. The details may vary much with the working of the house and the facilities given the chemist, and, as already said in the opening of the chapter, fundamental principles should be mastered rather than that details of methods in any particular sugarhouse should be copied, as the chemist must design his own scheme of control to fit the peculiar requirements of his house and the time and facilities at his disposal.

It hardly need be said that the whole scheme of chemical control is absolutely dependent on the accuracy of the *sampling*. Too little attention is paid to this in many houses. Obviously, the chemist cannot personally take every sample himself where the house is running continually night and day. Men in charge of sampling

should be trustworthy and intelligent, for negligence and incompetence here cannot be made good by the most careful laboratory work. In Europe, in the beet-sugar houses, there is a much better realization of the importance of the sampling, and elaborate registering and sampling apparatus is in use much more generally. That such apparatus is profitable seems unquestionable.

Beside the measurements and determinations which have reference to the accurate estimation of the work of the house, there are others which are valuable for the control of the daily factory operations. Some of the laboratory determinations for this purpose have already been discussed, such as acidity tests, density determinations of the meladura, etc.; but aside from these there are daily records kept for a definite twenty-four-hour period, starting at some fixed hour, say from six o'clock in the evening of one day to the same hour of the next. These figures are mainly of value in determining the efficiency of the various apparatus, as well as the sugarhouse as a whole, by giving the rate at which the product is worked up. Such figures are, for instance, bulletins of the starting and stopping of the mills, and of the number of defecators,¹ filter presses, crystallizers, etc., filled and emptied. These records, kept conspicuously placed for quick inspection, show at once the work of the house from hour to hour as well as for the complete day's run. At the end of the twenty-four-hour period these should be recorded in the laboratory books.

¹ One large Cuban sugarhouse has recently installed a watchman's clock system for electrically recording the defecator tallies. Numbered magneto call-boxes are placed at each defecator, from which workmen send signals which are recorded on the dial of a watchman's clock as each defecator is filled.

The best records of the work of the vacuum pans are made by *recording vacuum-gauges*. These give a continuous plot of the gauge readings during the whole twenty-four-hour period, so that the work of the pan is known at any hour of the day or night, within errors of a few minutes.

These curves have been found to be of great value, as they give permanent records of (1) the exact time the boiling is started; (2) the length and efficiency of the evaporation previous to graining; (3) the time the graining begins; (4) the length of the finishing period; (5) the exact time the strike is "dropped"; (6) the length of time that the pan is idle, which, in molasses-sugar strikes, is a measure of the time taken in filling wagons or crystallizers. Much other instructive information is often obtained from the gauge charts, such as the time and extent of irregularities in working of the condensing apparatus, etc. In connection with these records, those taken by recording gauges of the "live" and "exhaust" steam pressure are important, as they give data which are legitimately in the province of chemical control, and explain many irregularities in the work of the house which otherwise are interpreted by mere guess.

Such gauges should be placed in the laboratory or other office where they can be cared for. The greatest care should also be exercised in the installation of the connecting piping to avoid leaks and to insure the proper trapping of condensed vapor. If these precautions are not carried out, and such apparatus treated with the same care as any other instruments of high precision, it is worse than useless to install it.

In most first-class cane sugarhouses the chemist is the superintendent of sugar manufacturing, as he should be.

Beet-sugar Manufacture.— The conditions governing beet-sugar manufacture, as well as the chemical differences between beet and cane juices, have resulted in making it radically different from cane-sugar manufacture in many details of process. In this country at least,¹ refined sugar is made directly from the beet, and the extraction is universally by "diffusion," the extracted pulp being useless for fuel, but a valuable food for cattle. As beet sugar is manufactured in regions where fuel is comparatively cheap and water is abundant, the diffusion process can be used to great advantage.

As beets are not only bought by the sugarhouse, but also selected with great care for seed on tests mainly based on their polarization, beet testing is one of the most important and extensive operations of the factory laboratory. By this method of careful seed selection, the sugar content of the beet crop as a whole has been more than doubled in the past century.

In a large establishment, in seed testing particularly, often several thousand polarizations have to be made in a day. Much ingenious and labor-saving apparatus has been especially designed to meet the requirements of this great volume of work. Probably no industry has had its technology and special analytical methods more thoroughly exploited by eminent authorities than beet-sugar manufacture. The reader is, therefore, referred to the works

¹ In many countries, raw cane sugars are directly consumed as food. In fact, such sugars were common in our own groceries a generation ago. Raw beet sugars, on the contrary, are quite unfit for food, owing to their vile taste.

of Stohmann, Frühling, Claassen, Sidersky, Spencer, and others for details of these processes and methods.

Diffusion. — In this process the beets, in a finely chipped or sliced state, are subjected to the action of hot water. It can be considered as a kind of lixiviation process, but is to a considerable degree a clarification process as well, as the hot water tends to coagulate the albuminoids in the plant tissues. These matters are retained, together with other colloidal substances, by the cell membranes, which allow the sugar and salts to diffuse freely through. The beets, usually brought to the factory by small flumes of swiftly running water, are passed into a washer and then to the "cutters," where they are reduced by notched knives on a rapidly revolving wheel to a form resembling French fried potatoes. These "chips" ("cosettes") are fed into the "diffusion battery," consisting of ten or fifteen tall cylindrical (closed) iron tanks ("cells"), holding ten tons or more. These tanks are constructed to carry a moderate pressure and arranged so that the liquors can be passed from one to the other. The hot water, about equal in weight to the chips, is allowed to stand on the chips in a "cell" for twenty minutes or so, and then is passed to the next cell. When the battery is in operation, it is usually run so that all the cells are full except two, one which is filling, the other dumping. The diffusate, before leaving the battery, finally passes over at least one cell of *fresh* chips, and the work is commonly so arranged that it is the second diffusate of the three previous ones. Diffusion gives more extraction and a purer juice than any milling process, but dilutes the juice 15 or 20 per cent. The exhausted chips, after the excess of water is removed

by a specially designed press, are fed to live stock, the surplus being stored in covered trenches by a process of ensilage.

Clarification.— This differs radically from cane-sugar clarification, being much more elaborate than the former. This fact is chiefly due to the larger amount of albuminoids in beet juices and the greater difficulty of removing them, and also is a result of the conditions of manufacture already alluded to which favor the manufacture of refined sugar. The process is known as the “carbonatation” method, and in its essentials consists in treating the juice with a large excess of lime (about 2 per cent, although 3 per cent or more is often used) heating to 80°, and then precipitating the lime and coagulated albuminoids with *carbon dioxide*, which also decomposes the calcium succrate formed.¹ The juice is then passed through “bag filters” or filter presses. In this first carbonatation, the process is not complete, the juice being still somewhat alkaline. It is now treated with *sulphur dioxide*, and again with carbon dioxide till practically neutral, and the slight precipitate formed removed by “mechanical” filters, which are small closed tanks holding thirty or more flat bags stretched on wire frames. The juice filters from outside *into* the bags, and passes out by pipe connections in the frames.

A further treatment of the concentrated sirups with sulphur dioxide is usually given. The lime necessary for clarification is made at the factory by burning limestone in immense iron kilns similar in shape to blast furnaces,

¹ Carbonatation in modified form has been introduced in Java cane-sugar houses, but its advantages are questionable in raw cane-sugar manufacture.

so arranged that the carbon dioxide can be collected and pumped into the carbonation tanks.

The carbonation process is possible in beet clarification, owing to the absence of glucose sugars, for, as already stated, these are decomposed by excess of lime into slimy humus products which are hard to remove, and also give a brown (caramel) color to the sugar, very difficult to bleach. Normal beets are practically free from glucose sugars, but, in American practice, beets often have to be worked up which from various causes (unripeness, freezing, etc.) do contain considerable quantities of glucose.

Such beets require modification of the carbonation process to be worked successfully, the heating of the alkaline solutions being reduced as far as practicable, as well as the amount and duration of the alkaline state, while sulphur dioxide is used more freely to keep the clarified liquors neutral or even faintly acid.

The evaporation and crystallizing processes are identical with those of cane-sugar manufacture; so too, in its essentials, the centrifugal purging, the washing process during the purging being an important feature, as the sugar is turned out white. Subsequently, the sugar is passed through a "granulator," a long, slowly revolving, nearly horizontal drum, heated by a second internal steam drum. The sugar, which comes from the centrifugals with about 2.5 per cent of moisture, is thoroughly tossed about in the granulator, and perfectly dried, emerging as the "granulated sugar" of the grocer, and practically indistinguishable from the refinery product.¹

¹ Beet sugars refined in this manner do not hold their color quite as well as the bone-black refined product. On long standing, they gradually assume a slight yellow tint.

Second sugars, and occasionally thirds, are made from the purer sirups from the washing of the first sugars, being usually grained in crystallizers. The beet molasses (from normal beets) differs radically in many important characteristics from cane molasses. It has about 80 per cent of solids and averages about 50 per cent of sucrose, 10 per cent of ash, and 20 per cent of organic "non-sugar," largely nitrogenous, consisting of albuminoids and decomposition products of albuminoids. More than half of the mineral matter is potassium in combination with organic acids which are strongly melassagenic. This means that these bodies by their presence prevent the sugar from crystallizing, so that it is practically impossible to extract it by further boiling or ordinary methods of clarifying.

Many ingenious processes have been devised for extracting this sugar from the beet molasses. One which is quite often used is *osmosis*, in which the hot diluted molasses is made to flow through an "osmogene," very similar in appearance to a filter press, but composed of pairs of cells separated from each other by partitions made of parchment paper. Hot water flows on one side of the partition, the dilute molasses on the other. Many of the more soluble potash and other salts diffuse more rapidly than the sugar. By regulating the flow and temperature, sufficient melassagenic material of this nature can be removed, so that the molasses, on boiling in the vacuum pan and treatment with crystallizers, is said to yield some 12 per cent of its sugar. By further treatment of the molasses from the osmose sugar by a second osmosis and boiling, it is stated by Stohmann that 12 per cent of its sugar can again be obtained.

Another method of extracting sugar from beet molasses, which is used considerably, is known as *Steffen's process*. In this the diluted molasses is treated with lime till the sugar is converted into monocalcium sucrate, and into this solution is put fresh-burnt lime in very small portions at a time, while the temperature is kept at 15° C. by a cooling apparatus. In this way, finally, all the sugar is precipitated as a tricalcic sucrate, which can be filtered in filter presses, washed, and worked back into the juice, being substituted for lime in the carbonatation process. Strontium and barium hydrates have been substituted for lime in similar processes. The only impurity which is carried along with the sugar in this process is *raffinose*.

It will be seen from the above outline of beet-sugar factory methods that the scheme of chemical control will differ considerably from that of the cane-sugar house. Reference has already been made to the analysis of beets for seed and for establishing the purchase price, there being no difficulty in obtaining a representative sample, as in the case of cane. The usual method of obtaining the sample is by making a boring with a cylindrical rasp through the beet diagonally in a direction which experiment has shown to give a section representative of the average beet contents. The rasp is made to revolve very rapidly, and is so constructed that the raspings are retained in the hollow cylinder of the tool. In other rasps a wedge-shaped section is cut out of the beet, and drops into a metallic box.

Determination of Sugar in Beets.—The usual way is by the "hot digestion" method. The normal weight of pulp is washed into a funnel-mouthed flask, graduated to hold 201.35 cubic centimeters, the 1.35 cubic centimeters

being the allowance for the "marc" or pulp and the volume of the precipitate, 5 to 7 cubic centimeters of a basic lead acetate solution of a density of 1.25 having been previously run into the flask. The contents of the flask are nearly made up to the mark with water, and heated on a water bath for 30 minutes at 80° C. after thorough shaking and the addition of a drop or two of ether to dispel the foam. It is then acidulated with acetic acid and made up to the mark after cooling. The polarization is made in a 4-decimeter tube when practicable, to avoid doubling the reading. If a 200-cubic-centimeter flask is used, the weight of the pulp taken is 25.87 grams, instead of 26.048.

The analysis of the juice is made by the "indirect" method. The beet is cut up into small pieces and put through a screw fruit press, or, much better, rasped, and pressed in a very powerful laboratory press made for the purpose. The polarization and purity tests are made as for cane juices. The per cent of sugar in the *beet* is often calculated from the juice polarization by taking the arbitrary factor .95.

Ash Determination.— The methods of analysis of the diffusion juice are practically the same as for cane juices, but as the mineral matter plays such a large part in causing manufacturing losses, owing to its comparatively large amount and its strongly melassagenic action, its estimation is important. This is done by a determination of the ash of the juice. The ordinary method of making an *ash* determination of a saccharine solution is to dry 10 grams in a platinum dish, on a water bath, and then burn off the organic matter in a "low temperature" muffle, which is

kept at a dull red heat, not over 750° C. The organic matter is rapidly consumed at this temperature, which is not sufficient to volatilize the chlorides. Several methods have been devised for overcoming the difficulty of the excessive swelling of the carbonized mass in the preliminary stages of the burning, which is characteristic of carbohydrate substances. A very small lump of vaseline put in the dish before igniting works very well. In beet products,¹ however, it is customary to use Scheibler's method, and add a few drops of concentrated sulphuric acid, just sufficient to moisten the dried residuc, which will then burn without making a bulky coal in the preliminary stages. The "sulphated ash," as it is called, obviously is heavier than would be an untreated ash, owing to the higher molecular weight of the sulphuric radical. Scheibler found that in beet products a deduction of one tenth from the weight of the sulphated ash gave the equivalent of the normal ash. The *per cent of sugar divided by the per cent of ash* in a beet product is known as the "saline coefficient," and is an instructive figure to the beet-sugar manufacturer. Good beets give a coefficient of 20 or over.

Manufacturing Loss. — The first loss is in the diffusion chips and in the wash water expressed from the chips by the chip press. This approximates about .4 per cent on the weight of the beets.

The next losses occur in the carbonatation scums, which are polarized as described for cane-juice filter cake, except that care must be taken always to acidulate the solution

¹ Ash determinations should be made on the *filtered solutions* in case of raw sugars which contain sand and other foreign matter.

with acetic acid to decompose the lime sucrates present in the beet filter cake. A further loss occurs in the mechanical filtrations of the sirups, averaging .05 per cent. The chemical and other mechanical losses, which are those which have been enumerated under cane-sugar manufacture, bring the actual total losses to an average of about 1 per cent, although they figure .4 per cent or more larger, a result due, according to some authorities, to errors of polarizations, which are usually additive.

Quotient of Purity Tests of Beet Products. — The method of determining quotient of purity described for cane juices, in which the total solids is assumed to be given by the Brix reading, invariably gives too low results, owing to the large amount of mineral matter present, which has an influence on the density over twice as great as that of sugar. A solution of calcium chloride of 1 per cent, for instance, would read nearly 2.5° Brix. Hence, it is necessary for accurate work to obtain the total solids by *drying*.

Drying of Saccharine Products. — It is very difficult to determine moisture accurately in sirups and other solutions of sugar, because as the drying proceeds, an impervious varnish of the saccharine material forms over the surface, which confines the moisture of the lower layers. For satisfactory drying, the solution during drying must be distributed in very thin films over a large surface. This is done most effectively by diluting the substance to a thin sirup and pouring it over clean sand or pumice stone, and then evaporating at a temperature of 105° C. in a hot-air oven, till a practically constant weight is obtained, — *practically* constant, because the drying is

beset with another difficulty, the gradual increase in weight due to the oxidation of the sugar, which takes place rapidly in the dried product at the air-bath temperature. The usual method of determining the point of dryness is when the loss in weight does not exceed .2 per cent per hour.¹

This oxidation error is mitigated by drying in a vacuum at 70° C. Lobry de Bruyn and Van Laent² have used a vacuum apparatus arranged so that in the final stages of drying the vapors are passed over phosphorus pentoxide. Brown, Morris, and Millar have dried most of the common carbohydrates with this apparatus, and determined their density influences per gram in 100 cubic centimeters for all concentrations up to about 25 per cent. This apparatus is somewhat complicated and the process tedious for commercial work. The method almost universally used in refineries and sugarhouses is drying in the hot-air bath at 105°.

Weisberg has worked up a table of coefficients for transforming "apparent quotients" (those obtained by the Brix spindle) into true values. It is said to give correct results when the solution of the beet product is made up to the normal (saccharimeter) concentration of 26.048 grams in 100 Mohr cubic centimeters. Usually two or three times the normal weight is taken in the corresponding volume to allow of sufficient solution for the Brix determination. The following is the table of Weisberg :

¹ The United States Custom House method for determination of moisture in molasses and sirups is to spread 1 to 2 grams over the bottom of a flat dish at least 7 centimeters diameter, and dry for two hours at 100° C.

² Rec. Trav. Chim., 13, 218.

APPARENT QUOTIENT	COEFFICIENT	APPARENT QUOTIENT	COEFFICIENT
57.0	1.054	79.0	1.020
57.5	1.052	80.0	1.019
58.0	1.050	81.0	1.018
59.0	1.046	82.0	1.017
60.0	1.044	83.0	1.016
61.0	1.042	84.0	1.015
62.0	1.040	85.0	1.014
63.0	1.038	86.0	1.013
64.0	1.036	87.0	1.012
65.0	1.034	88.0	1.011
66.0	1.033	89.0	1.010
67.0	1.032	90.0	1.009
68.0	1.031	91.0	1.008
69.0	1.030	92.0	1.007
70.0	1.029	93.0	1.006
71.0	1.028	94.0	1.005
72.0	1.027	95.0	1.004
73.0	1.026	96.0	1.003
74.0	1.025	97.0	1.002
75.0	1.024	98.0	1.002
76.0	1.023	99.0	1.001
77.0	1.022	100.0	1.000
78.0	1.021		

Weisberg's method is particularly adapted for determining the quotient of purity of massecuites.

The chemical determinations necessary for controlling the daily work of the beet-sugar house are evidently much more various than those of cane-sugar manufacture, and comprise analyses of the limestones used in the kilt, as well as the lime itself, the kiln gases used in carbonatation, alkalinity tests of the juices and sirups in process, besides occasional analyses of fuel, boiler deposits, fertilizers, etc.

Moreover, there is much chemical work which could be done to advantage, both in cane and beet sugar laboratories, not only directly bearing on the work of the factory, but in research work on problems constantly arising. However, very few factory laboratories have the facilities for more than the necessary routine control work.

Refinery Methods. — The refinery takes raw sugars of all sorts, the great bulk of which is turned into a product which is practically chemically pure white sugar, mostly in granulated form, although considerable is manufactured into the various forms of “lump” or “loaf” sugar, and moist “yellow” sugars.

As has already been explained, raw sugar reaches the refinery in many forms and qualities. . There are, however, practically four classes of sugars which are recognized: (1) first centrifugal cane sugars, (2) second, or molasses, and muscovado sugars, (3) beet sugars, corresponding to cane first sugars, (4) “jaggerys” and other crude products of primitive manufacture.

With the exception of beet sugar, the price of the sugars in each class is directly fixed by the polarization. In valuing beet sugars, the amount of mineral matter (ash) is also taken into consideration, as this is largely a constituent of melassagenic salts. The custom is to subtract five times the ash per cent from the polarization in valuing the sugar. For instance, a beet sugar polarizing 96 per cent with an ash of 1.25 per cent would be rated as a cane sugar polarizing 89.75 per cent. This is based on actual results obtained in European refinery practice, but is said by some authorities not to apply except to what are known as “export sugars,” the only kind of raw beet sugar which

reaches the United States. The ash of the lower grade cane sugars is also often determined in order to classify them.

The better grade of raw sugars are at once washed in large centrifugal machines, by which 90 per cent or more is separated as crystals of practically white sugar of a purity of about 99.5, for the greater part of the impurities exist as a coating on the crystals, and so can be collected in the wash sirups.

The washed sugar is dissolved in the "melters" to a sirup of about 30° Beaumé, which is defecated in a manner similar to that used in raw-sugar manufacture, although other coagulants are often used with lime, the suspended solid matters customarily being removed by passing through "bag filters." The clear sirups are then decolorized by bone black in the "char filters," and the practically colorless sirups boiled in vacuum pans and the sugar separated and washed white in centrifugal machines by the methods already described. The sugar is dried in granulators, and is ready for market after sifting into different grades of fineness and packing. The sirups from the preliminary washing of the raw sugar are mixed with the "meltings" of the lower grade sugars and subjected to an identical process, in most cases precipitants being used with the lime for more effective clarification. Finally, the washings from the bone-black filters and other apparatus, and from the bag-filter scums, if not utilized in the melting, are concentrated in a multiple-effect evaporator, and worked into the other liquors. The sirups from the refined sugars are reboiled in the vacuum pan for sugar, the less pure ones being used for charging

after the grain is formed. When the purity of the sirups from the reboiling falls below a certain value, say about 84, it is no longer profitable to boil them in the pan without further refining, unless to make soft yellow sugars. These sirups are therefore added to others in process at a stage depending on their purity, or boiled to low-grade sugar, which is remelted. In fact, practically the whole work of the refinery is governed by the *purity tests* of the liquors in process, by which is determined the most effective way to combine the different lots for most economical refining. When it is known that in the larger refineries 1500 tons or more of sugar are refined daily, it will be readily seen that failure to take advantage of the most effective blending or working up of the diverse sirups and liquors in process may mean large money loss. Finally, when the purity of the sirups put constantly back in process in different ways falls below about 45 actual purity, it is no longer profitable to re-work them for sugar, and they are sold as "barrel sirups" (English, "treacle") for use as food sirups or in brewing.

From what has been said in this rough outline of the complicated process of refining, it will be evident that, beside the polarization of the raw sugars and the refined products, the determination of the quotient of purity of the many and various liquors in process will be an indispensable function of the laboratory; in fact, its most important work, as by it is controlled the entire arrangement of the refining of the different stock in process. Perhaps the next most important routine work of the refinery laboratory is the control of the bone-black filtration. Bone black is indispensable as a decolorizer in sugar refining. It is

one of the greatest items of cost, as the material is expensive, requires elaborate machinery for its handling, and undergoes considerable loss by disintegration in treatment. About a pound of bone black is required per pound of sugar decolorized. After bone black has been used a short time, its pores become clogged, and it loses its decolorizing power. It is then washed and partially dried by steam, passed through a dryer, heated to dull redness in tubular retorts¹ to consume the organic material which clogs its pores, and finally passed through revolving screens to remove the finer disintegrated part, which is rejected as "spent black," still valuable for many purposes, from the phosphate it contains. New black often has to undergo a preliminary treatment with dilute acid and a washing known as "tempering" before it can be used. If the various processes of "revivifying" the black are not carried out properly, the pores of the revived black become clogged with carbonaceous and mineral matter, to the great loss of its efficiency. Hence, the daily condition of the black must be closely followed by the chemist by analysis, particularly determinations of the carbon and lime content.² The amount of phosphate is also important as a measure of the durability of the black.

As a rule, the chemist of a refinery has little to do with the active management of the refinery, or in fact with the

¹ Sometimes the bone black is subjected to a roasting process known as "decarbonizing." This volatilizes considerable of the organic matter clogging the pores of the black, which would otherwise be deposited as carbon in its passage through the retorts. Formerly the bone black was allowed to stand in heaps to allow this organic matter to be destroyed by fermentation.

² For methods of bone-black analysis, see Tucker, "Manual of Sugar Analysis."

calculation of yields and losses. These calculations are so extensive and complicated that they are usually made part of the bookkeeping of the office force, under direction of the superintendent and his assistants, the laboratory records being practically confined to the actual analytical work.

The losses in a refinery, according to European practice, are said to be .5 per cent mechanical and .55 per cent chemical, on the weight of the raw sugar actually refined.

CHEMICAL METHODS OF DETERMINING SUGARS

ALL the common glucose and saccharose sugars, with the exception of sucrose, exert a marked reducing action when heated with alkaline solutions of many metallic salts. This behavior is characteristic of organic compounds known as "aldehydes" and "ketones," which can be considered as partially oxidized from hydrates (alcohols) and in a transition state between the latter and the more completely oxidized form of the acid. Consequently, like all readily oxidizable chemical compounds, they are strongly *reducing* in their action. All the sugars are known to have an aldehyde or ketone structure, being sometimes classified as "aldoses" and "ketoses."

The Fehling Volumetric Method.—In 1848 Fehling developed a practical method for utilizing this reducing property of the sugars on copper salts as a means of quantitative determination of the sugars themselves. Fehling used a strongly alkaline solution of copper tartrate for his metallic solution, the concentration of which was so designed that the copper salt in 10 cubic centimeters of this solution would be completely reduced to cuprous oxide, when boiled with .05 gram of dextrose, under the conditions of the process.

Fehling's original solution, according to Wiley, is made as follows: 34.64 grams of pure crystallized copper sul-

phate (free from efflorescence) is dissolved in a small quantity of water (less than 300 cubic centimeters), and 90 grams of sodium hydroxide is also dissolved in about 600 cubic centimeters of water in which is subsequently dissolved 150 grams of potassium tartrate. The solutions are then mixed and made up to 1000 cubic centimeters. Later, 173 grams of the double sodium-potassium tartrate ("Rochelle salt") was substituted for the potassium tartrate.

Nearly thirty modifications of Fehling's original solution have been made, the majority of which vary mainly in the amount of alkali used. Owing to the fact that Fehling solutions decompose spontaneously after a short time and precipitate copper, the modern formulæ are for two solutions, one containing copper sulphate, the other alkaline tartrate. If the copper sulphate solution is made slightly *acid* with a cubic centimeter of sulphuric acid per liter, and both solutions kept in tightly stoppered bottles of good glass, they will keep indefinitely. A mixture of equal volumes of the two solutions gives the Fehling liquor. Soxhlet's formula is as follows :

Solution No. 1. — Copper sulphate in crystals, 69.28 grams in 1000 cubic centimeters of water.

Solution No. 2. — Rochelle salt, 346 grams dissolved in about 600 cubic centimeters of water, to which is *then* added 100 grams of sodium hydroxide in 200 cubic centimeters of water. Solution made up to 1000 cubic centimeters.

The original method of Fehling is a volumetric one, and according to Sutton is as follows: 5 cubic centimeters of

each solution is measured into a small porcelain dish, the resulting 10 cubic centimeters of clear deep blue Fehling liquor diluted with 40 cubic centimeters of water and quickly heated to boiling. The sugar solution which must be at a concentration of about .5 per cent, is then run in from a burette in small quantities till the blue color of the copper just disappears. The volume of sugar solution added to decolorize is assumed to contain .05 gram if dextrose, other sugars giving different reduction weights.

Unfortunately, the reduction value obtained varies considerably with the manipulation, being dependent on the length of boiling, the exposure of the solution to the oxidizing influence of the air, and the amount of sugar present at different steps in the titration. Many attempts have been made to improve the volumetric process so as to reduce the inherent errors.

None of these improved volumetric methods seem to have any advantages over the original one of Fehling, when the following conditions are observed, these being vital for accuracy, whatever the method used :

(1) To arrange for the concentration of the sugar solution, or the dilution of the Fehling liquor, so that in all determinations the volume of the boiling liquid is a fixed one; (2) to add at once practically *all* the sugar solution necessary to decolorize the Fehling liquor; (3) to carry out the test under as uniform an air exposure as possible, *i.e.* in flasks of uniform size and shape; (4) to boil with the Fehling solution uniformly for a fixed period. The disappearance of the copper from the solution by precipitation can be determined conveniently by spotting a drop

on a tile or on the paper prepared for the purpose, and testing the clear portion of the spot with potassium ferrocyanide acidified with acetic acid.

Hence, it cannot be assumed, except in very rough work, that .05 gram of sugar is necessarily the exact amount to discharge the color of 10 cubic centimeters of Fehling liquor under the conditions of analysis. Each operator should determine for himself what the reduction factor is as he personally carries out the test, by standardizing the Fehling liquor with a solution of pure dextrose or invert sugar.

Standard Dextrose Solution.—Chemically pure anhydrous dextrose can be obtained of the dealers in pure chemicals. It is, however, best to recrystallize in pure alcohol before using. The principal impurity in anhydrous dextrose is moisture, and as the sugar is troublesome to dry, the better way is to prepare an approximately 10 per cent solution, and determine the exact amount of dextrose contained by means of the density taken with the pycnometer. The density factors at 15.5° C., referred to water at 15.5° C., have been worked out with great exactness by Brown, Morris, and Millar.¹ For a solution of approximately 10 per cent, the grams of dextrose in 100 cubic centimeters (Mohr, 15.5°) are given by the following equation: $w = \frac{d - 1}{.003835}$, where w is the number of grams in 100 cubic centimeters of solution, and d the density. Knowing the concentration of the dextrose solution, its purity can be established by a determination of its specific rotatory

¹ *J. Chem. Soc. (London)*, 1897, 71, p. 73, also p. 275.

power.¹ $[\alpha]_D$ of an approximately 10 per cent solution of dextrose at 20° C. is 52.74 according to Landolt.

Standard Invert Sugar Solution.—According to Frühling, this is made as follows: 9.50 grams of pure cane sugar are dissolved in 75 cubic centimeters of water in a 100-cubic-centimeter flask, and 5 cubic centimeters of hydrochloric acid of a density of 1.19 added, and the whole thoroughly mixed. The solution is then heated in a water bath kept at a temperature of 70°, the flask being immersed in the water up to its neck. The solution should reach the bath temperature in from 2½ to 5 minutes, and the heating should be continued⁶ for 5 minutes more.

The solution is then cooled to the room temperature and diluted to the 100-cubic-centimeter mark. Fifty cubic centimeters of this solution, corresponding to 5 grams of invert sugar, are put into a liter flask, carefully neutralized with sodium carbonate, and made up to the mark. This solution, every cubic centimeter of which contains .005 gram of invert sugar, is used to standardize the Fehling solution.

Theoretically, in the volumetric Fehling reaction, one equivalent of dextrose, of a molecular weight of 180, reduces ten equivalents of crystallized copper sulphate ($\text{CuSO}_4 \cdot 5 \text{H}_2\text{O}$) of a total molecular weight of 2494, but actually, at the same time as the sugar is being oxidized, the action of the alkali present is to break up the sugar molecule into a complex mass of decomposition products,

¹ Dextrose, like many other sugars in the crystalline state, when freshly dissolved has a temporary specific rotation which gradually changes to the normal value after some hours. If heated to boiling, the solution at once gives the normal specific rotation. Hence, the solution should be brought to a boil and cooled before polarizing. This phenomenon will be discussed later.

salts of numerous organic acids. As already noted, the air also exerts a marked oxidation.

Many attempts have been made to devise solutions doing away with the alkali,¹ but this seems essential. Any decrease in quantity of the alkali, whether potassium or sodium hydrate, decreases the sensitiveness of the Fehling solution to reduction. Ammonia has been substituted for sodium or potassium, in part or whole, by Pavy and others, as the former does not act so energetically on the glucose molecule. These solutions give a very sharp end point, as there is no precipitate of cuprous oxide to obscure the solution, and are valuable in cases where ammonium or its derivatives are already present in the solution, but are inconvenient, owing to the necessity of providing for a uniform ammonia content during the titration and the exclusion of air. The reader is referred to Wiley's "Principles and Practice of Agricultural Analysis," volume III, for a more extended description of Fehling and similar methods.

The Fehling volumetric methods are much used in sugar analysis, owing to their rapidity, and are valuable where small quantities of invert sugar or glucose are to be determined within a few per cent of their value, which is usually all that is required in commercial work, but in general can hardly be depended on for more accurate work. When greater precision is required, the *gravimetric* methods are necessary.

¹ One of the most promising of these is the Soldani method as developed by Ost (*Ber. d. chem. Ges.*, 23, 1035, 3003; 24, 1634; *Zeits. anal. Chem.*, 29, 637). The solution used is one of copper carbonate in potassium carbonates. I have had no experience with this method.

Gravimetric Fehling Methods.—These are numerous, but the same general principles prevail in all of them. The Fehling solution, or its modification, is present in excess. The cuprous oxide precipitated during a given period of heating, and under, as nearly as possible, fixed conditions of relation between the sugar, copper solution, and dilution, is taken as a measure of the amount of sugar present. The reduction is carried on by direct boiling or by more prolonged heating on a water bath. The copper is determined, either as cuprous oxide, cupric oxide, or reduced by hydrogen to the metal, it being a matter of indifference which, provided the proper procedure is followed. In some cases the washed precipitate is dissolved in nitric acid and the copper determined electrolytically or volumetrically by the usual methods. One way is to dissolve the washed cuprous oxide in a standard solution of ferric sulphate, and determine the ferrous salt formed by standard permanganate solution. Many prefer to use copper solutions containing more alkali than the Soxhlet solution contains. Such solutions have greater sensitiveness to reduction, but reduce to a slight extent spontaneously, so that blank corrections must be made.

‘ Whatever the method chosen, the *time and conditions of the heating*, as well as the *concentration of the Fehling liquor* and the *extent of surface of the hot solution exposed to the air*, must be *uniform* in all tests. As in the volumetric processes, these conditions are vital to accuracy.’

Usually the cold sugar solution is added to the Fehling liquor after the latter has been heated to the temperature at which the reduction is carried on. The length of time taken to add the sugar solution and the conditions of

admixture of the two solutions have considerable influence on the reduction, especially where the heating is done on a water bath.

As illustrative of a standard gravimetric method carried out by direct boiling, the following is that of Herzfeld for determining invert sugar:

The solution in which invert sugar is to be determined is made up so that 100 cubic centimeters contain 20 grams of sample, *after* clarification with basic lead acetate and removal of the soluble lead in the filtrate by sodium carbonate.¹ The German way of doing this is to dissolve 27.5 grams of sample in 125 cubic centimeters, the solution being made up with basic lead acetate, as for polarizing, and filtered; 100 cubic centimeters of the filtrate are put into a 100–110-cubic-centimeter double-marked flask, and 10 cubic centimeters of sodium carbonate added, the solution after mixing being again filtered.

1. If the sample has been shown to contain *less than 1 per cent* of invert sugar (by a rough volumetric test, 20 cubic centimeters failing to decolorize 12 cubic centimeters of the Fehling solution by 2 minutes' boiling), 50 cubic centimeters are taken for the exact gravimetric test.

2. If the sample is shown to contain *more than 1 per cent* of invert sugar, the solution containing 20 grams of sample in 100 cubic centimeters must be diluted to correspond to one made from a sample containing 1 per cent of invert sugar. This dilution is determined with sufficient exactness by preparing in large test tubes dilute solutions containing respectively 1, 2, 3, 4, and 5 cubic centimeters

¹ Potassium oxalate is preferred by some (Sawyer, *J. Am. Chem. Soc.*, 26, 1631).

of the 20-gram solution, adding 5 cubic centimeters of Fehling solution, and boiling two minutes. The tube showing a solution which (after the copper precipitate has been removed by subsidence or filtration) is still blue but lightest in tint is noted, and twenty times the number of cubic centimeters of original solution contained in this tube is dissolved in 100 cubic centimeters. Of this final solution, 50 cubic centimeters is used as before, for the exact gravimetric test, which is as follows:

Fifty cubic centimeters of the sugar solution are mixed with 25 cubic centimeters each of the two constituent solutions of the Fehling liquor, in a 250-cubic-centimeter beaker, and the whole heated on a wire netting on which is laid a sheet of asbestos paper having a circular hole cut in it 6.5 centimeters in diameter. The flame of the burner is so regulated that it takes $3\frac{1}{2}$ to 4 minutes to bring the contents of the beaker to a boil. Then the boiling is continued 3 minutes exactly, when the beaker is immediately cooled by the addition of 100 cubic centimeters of cold distilled water. Evidently all the conditions for a constant factor of reduction exist in this method except the inevitably variable proportion of sugar to the copper solution; but, as this variable is measured by the amount of cuprous oxide precipitated, a table has been devised by Herzfeld giving the equivalent of sugar for the weight of copper obtained. Herzfeld has made his tables for invert sugar determination and determined the reduction by the amount of copper actually obtained by reduction from the oxide.¹ The precipitate is collected in a "Soxhlet tube," a long, straight funnel tube packed at the lower end with asbestos

¹ See Appendix, Tables Nos. 7 and 8.

held in place with a platinum sieve. The tube is placed on a suction flask and the Fehling liquor with the precipitated cuprous oxide poured into it through an ordinary funnel attached by means of a stopper. After the precipitate is collected and quickly washed with hot water, it is attached to a hydrogen generator and the oxide heated to glowing while the gas is passing. This quickly reduces the oxide to the metallic state. The tube is then placed in a desiccator and, after cooling and coming into equilibrium with the atmosphere, is weighed. Special platinum dishes equipped with tubulated covers have been devised in which the cuprous oxide, collected on a filter paper in the ordinary way, can be reduced and more conveniently weighed. Sometimes the cuprous oxide is weighed directly by washing in a Gooch crucible, and then adding 10 cubic centimeters of alcohol and afterward 10 cubic centimeters of ether, then drying at 100° C. for half an hour.

Another way is to heat the cuprous oxide, collected in a Gooch crucible, to redness for fifteen or twenty minutes. This converts it into the cupric oxide, which is more stable than the cuprous. Cupric oxide is, however, very hygroscopic, and requires special care in handling, to avoid error from moisture. Obviously it is immaterial whether the reduction tables are figured in weights of copper or copper oxide, as the values are convertible by the appropriate factors.

The method of Defren,¹ adapted from O'Sullivan, can be

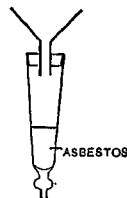

FIG. 29.—SIXHOLE TUBE WITH FUNNEL ATTACHED.

taken as illustrating the conduct of the test by heating on the water bath. In this method 15 cubic centimeters each of the white and blue solutions of the Fehling liquor are taken in a 100-cubic-centimeter Erlenmeyer flask, proportioned so that its base diameter is between one third and one half of its height. The Fehling liquor is diluted with 50 cubic centimeters of water, and heated by immersion in the water for 5 minutes, in order to come to the bath temperature. Then 25 cubic centimeters of the sugar solution are run in and thoroughly mixed, and the solution heated for exactly 12 minutes in the water bath.

The precipitate is then filtered off into a porcelain¹ Gooch crucible, having an asbestos mat about one centimeter thick, ignited, and weighed as the cupric oxide. Great care must be taken in the preparation of the asbestos used in these filters. It must be thoroughly boiled in 1.10 nitric acid, thoroughly washed, and then boiled with a 10 per cent solution of caustic soda and washed. It is sometimes advisable to repeat this treatment with acid and alkali. The crucible, after preparation of the asbestos mat, is ignited to constant weight.

The following procedure is advisable in working with porcelain Gooch crucibles, to prevent their cracking: The crucible, after removing from the filter flask, is placed on a "radiator," a heavy, hollow, cast-iron cone, about 7 centimeters in diameter, in the open base of which is a platinum wire triangle for holding the crucible. When this inverted cone is heated over a burner, it gives out a moderate, even heat, which will not crack the crucible, even if it is immediately removed from the filter flask.

¹ Platinum crucibles can be used to advantage.

After a few minutes, the hot, dry crucible is transferred to a large nickel or platinum crucible, heated to a bright red, where the ignition is completed.

As already stated, the manner of applying the sugar solution has an important influence on the result. Defren's tables were calculated for a reduction taking place when the solution was added from a burette to the flask previously removed from the bath. Slight variations in this part of the procedure, in the time taken to add the solution, the cooling caused by the admixture, and the stirring, are all liable to make variations in the amount of total reduction.

In fact, whatever the Fehling method employed, inasmuch as very slight changes in the manipulation, not covered by the details of the description of the method, often affect the reduction factors materially, in accurate work the analyst should cultivate as uniform a habit of procedure as possible, even in minor details of manipulation, and carefully check his work by standard sugar solutions of known value, until his determinations give results in accord with the tabulated values given by that method, or should determine the values for his own work. This is imperative in cases of investigations of hydrolyzed starch products, for instance, where slight variations in the reducing value are significant; but in the case of the determination of invert sugar in cane or beet sugar liquors, where the invert sugar content is small, an error of a few per cent of the actual value obtained is often insignificant, and consequently does not call for such refinement.

Blank Fehling tests should always be made with new Fehling solution, carrying out every condition of the

regular sugar determination, for although with the Soxhlet solution no reduction should take place, sometimes such fermenting liquors do show "spontaneous reduction," especially if the Rochelle salt is of inferior quality.¹ In the case of the investigation of certain products, where the reduction is small, and the amount of impurity, such as lime or lead, is large, this must be removed before making the test. In some such cases it will be better, obviously, to dissolve the cuprous oxide in nitric acid, and determine it electrolytically. The intelligent worker will modify his method according to circumstances. The dilution of his sugar solution should be taken so as to have at least .1 gram of precipitated oxide.

Cupric Reducing Power. — In the identification of the different sugars and starch products, it is often convenient to calculate the reduction as a value of the pure substance referred to the reduction value of an equivalent weight of *dextrose* taken as 1.00. This is known as the "cupric reducing power" of the substance, and symbolized by the Greek letter κ . For instance, the cupric reducing power of maltose is .62, that of invert sugar .95, etc., which means that maltose reduces .62 as much copper solution as the same weight of *dextrose* under the same conditions of test; invert sugar, .95 as much.

Under different conditions of reduction prevailing in different methods, the cupric reducing powers of different sugars do not give the same constant value.

¹ Blank tests also show whether all soluble matter has been removed from the asbestos by the chemical treatment described. The crucible should show no change in weight.

STARCH AND STARCH PRODUCTS

Chemistry of Starch.—Starch is vital to higher plant life, and while widely distributed in vegetable tissue, especially makes up a large part of the substance of many grains and tubers. As found in nature, it is in the form of minute granules, of a density of 1.6, the shapes of which vary much in starches from different plants, but are so characteristic that investigation with the microscope will, in most cases, easily determine their botanic origin. While authorities differ as to the exact structure of the starch granule, from the standpoint of the chemist it may be considered as composed of a mass of carbohydrate paste, inclosed in denser tissue of apparently the same general chemical composition, known as “starch cellulose.”

The unbroken starch granule is insoluble in cold water, but if a mixture of starch and water is heated to about 70°, the exact point differing with different starches, the starch suddenly swells to a pasty jelly. The microscope shows that this is the result of the expanding of the interior contents by absorption of water till the enveloping tissue of starch cellulose has been ruptured, the greatly swollen jelly contents escaping.

If the cell structure is ruptured mechanically by grinding starch with sharp quartz sand, or the “cellulose” removed chemically by dilute solutions of alkalies, zinc

chloride, or other solvents, the same thing occurs. At the same proportions of starch and water, the *consistency* of pastes made from starches of different origin differs much, and, in consequence, starches have been placed in two classes, — “thick boiling” and “thin boiling.” It is now known that the conditions of the process by which the starch has been extracted from the plant have much to do with this pasting property.

Chemically classified, it has been shown by Brown and Millar that starch paste is a highly condensed hexose carbohydrate of the formula, $100 C_6H_{10}O_5$, which can be considered as an aggregation of 100 anhydride groups derived from dextrose by the removal of as many equivalents of water. As would be expected, such a complicated body is easily resolved by hydrolytic agents into simpler combinations, finally becoming dextrose, a result which can practically be attained by prolonged acid hydrolysis.

If the hydrolysis with acid is followed from the beginning, there is found to occur a gradual disintegration of the starch into products which chemically can be considered as molecular aggregations of three well-defined compounds, — *maltose* ($C_{12}H_{22}O_{11}$), a *dextrin* ($C_6H_{12}O_6(C_6H_{10}O_5)_{39}$), and *dextrose* ($C_6H_{12}O_6$).

If an *enzyme* is used as the hydrolytic agent, such as *diastase*, which is the active principle of malt, the hydrolysis under ordinary conditions does not go on till dextrose is the final product, but the compounds formed are aggregates of maltose and dextrin only. The hydrolysis under different temperature conditions of the diastase action has been found to follow well-defined reactions. The one occurring at $45^\circ C.$, and most favorable for the production

of the greatest amount of maltose, can be expressed by the following reaction :

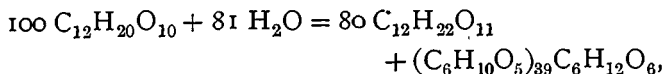

action ceasing when these compounds have been formed in the proportions given by the equation, and the solution coming into chemical equilibrium.

In *acid* hydrolysis there is a progressive decrease in the dextrin constituent as the action continues, and a similar increase in the amount of the dextrose which is formed in this hydrolysis. The maltose at first increases rapidly, but, after reaching a maximum of about 45 per cent of the total carbohydrate, diminishes as rapidly, till, at the completion of hydrolysis, it is entirely converted into dextrose. At no point in the hydrolysis, except at the very beginning and end, are any of these constituent carbohydrates entirely absent. The gradual disintegration of the starch molecule and the different stages of the hydrolysis of the products of this disintegration all go on at the same time, so that the final products of hydrolysis are always present in very small quantity even at the initial stages of the hydrolysis.

The progression of the hydrolysis manifests itself in the following characteristics: The starch paste gradually loses its colloidal nature and passes over to a thin sirup, its viscosity continually decreasing. The dissolved carbohydrate increases in weight, but the *density*, proportionally, continually decreases, that is to say, the density effect of a given weight of carbohydrate in a given volume of solution continually decreases. The specific rotation of the carbohydrate, taken as a whole, likewise decreases,

while its cupric-reducing power increases, these values progressively approaching those for dextrose.

The iodine tests are also characteristic; a few drops of iodine solution giving, with the hydrolyzed solutions, at ordinary temperature, colors which change progressively as the hydrolysis proceeds, from the deep sapphire blue of the unchanged starch, first to violet and reddish purple, then to a rose madder, and then to a reddish brown, growing lighter as the conversion proceeds, till at a later stage, but before hydrolysis is complete, the iodine gives no color reaction.

These colors are so characteristic that an expert can follow the progress of the hydrolysis with considerable precision. In commercial hydrolytic processes, as the manufacture of "commercial glucose," they are depended on to define the requisite point of "conversion."

By precipitation with alcohol, numerous well-defined compounds, known as "dextrins," can be separated from hydrolyzed starch products, which give colorations with iodine corresponding to the degree of hydrolysis of the starch solution from which they were obtained. These products behave, however, chemically and optically, as if they were mixtures of maltose, dextrose, and the primary constituent dextrin already alluded to, so they need not be considered here. Other reactions of starch will be referred to only when necessary for explanation of the subject at hand.

Commercial Starch. — Although starch is so widely distributed in vegetable tissue, constituting a large proportion of our food products, comparatively few plants are utilized in making the commercial product. Among these, by far

the most important in this country is Indian corn (maize). In Europe, starch is made almost exclusively from potatoes; some potato starch is made in this country also. Wheat starch is likewise of commercial importance, the starch being manufactured from flour. Tapioca and rice starches are made in the far East, and brought to this country, the former being a recent product of Florida from the cassava root.

The general methods of starch manufacture naturally fall into two classes: (1) those in which the albuminous by-products (gluten) are saved and utilized; (2) processes where the gluten is decomposed by fermentation or chemical methods.

Originally, the gluten was removed entirely by fermentation and lost, but by modern methods most of this is now saved and utilized in various ways. The ferment acids arising from the destruction of the gluten by the older processes always produced an incipient hydrolysis which made the starch to a greater or less degree "thin boiling."

The general principles of process of making commercial starches are as follows: (1) Breaking down the plant tissue in such a way that the starch grains are set free but not ruptured. (2) Separation from the gluten, usually by diluting the mixture of starch and gluten with a large amount of water, and then settling out the heavy starch by subsidence in tanks or by flowing the diluted mixture down long, very slightly inclined canals ("runs") in which the starch is deposited. (3) Washing the starch by agitating with water in tanks. (4) Draining off the starch from the starch "milk" in cloth-bottomed "draining boxes" or in filter

presses of special design. (5) Drying the starch in hot rooms ("kilns").

Grains have to be steeped in warm water for several days before they can be ground. In the case of wheat starch, the gluten of which is thick and rubbery, balls of dough prepared from flour are worked in a special kneading machine, the starch being washed out during the kneading by jets of water.

As already stated, starches derived from different plants vary considerably in the thickness ("body") of the pastes they make when mixed with hot water, some being quite liquid, others, at the same concentration, being too dense to flow. It has been found that this quality of the starch depends largely on the amount of hydrolytic change to which the starch has been subjected in the necessary detail of process. Consequently, manufacturers have learned to control this pasting property to a considerable extent, so that products can be made to suit the special requirements of the customer.

The manufacture of corn starch is by far the most important branch of the industry, and in no other has the utilization of by-products and the development of manufactures derived from starch been carried so far.

As corn starch is made in conjunction with glucose and grape sugar, special reference will be made to this later.

Methods of determining Starch.— Numerous methods have been proposed for the determination of starch, especially in grains and foods prepared from grains. Most of them depend on the following principles, it being advisable and in some cases necessary to dry the sample and remove

the fats, and of course *essential* in every case that the sample be ground to the *greatest possible fineness*, and that all other carbohydrates which are soluble in water or alcohol, such as sugars, gums, and dextrans, be previously extracted: (1) Dissolving out the starch by hydrolyzing with malt extract, and determining the starch by difference. (2) Completely hydrolyzing the starch with hydrochloric acid, and determining the dextrose formed by the Fehling method. (3) Dissolving and filtering off the starch as in (1), then completing the hydrolysis with acid and determining the dextrose. (4) Same as (3), except that starch is dissolved by heating with water under steam pressure of about three atmospheres, by means of an autoclave. (5) Partially hydrolyzing with salicylic or nitric acid, and polarizing the solution. (6) Determining the amount of standard barium hydrate which will combine with the pasted starch. None of these methods are very satisfactory, although most of them are accurate with *pure* starch.

The solution method, in which the starch is determined by difference, assumes that starch (from which the water-soluble carbohydrates have been removed) alone is dissolved out by malt extract, but it is known that some of the proteid matter is also dissolved.

With the acid-hydrolysis method, in the case of grains particularly, other carbohydrates which are present, especially "pentosans,"—carbohydrates containing five equivalents of carbon, of the general formula $(C_5H_8O_4)_n$, analogues of starch,—are hydrolyzed into *pentose* sugars, which also reduce Fehling solution, and so introduce error.

The polariscope methods are unsatisfactory, owing to the difficulty in getting clear solutions and the large amount

of substance required. The barium method is of doubtful reliability, except with very pure starches. The methods following the principles given in (3), in which the starch is partially converted by malt extract, and separated from the other substance previous to completing the conversion to dextrose, are considered the most reliable, as experimental evidence tends to show that pentosans are unaffected by diastase, which is the active enzyme of malt.

When pentosans are absent, the method of Sachsse by simple acid hydrolysis is the standard, and is as follows: An amount of dry substance containing 2.5-3 grams of starch is heated on a boiling-water bath with 20 cubic centimeters of hydrochloric acid, of a density of 1.125 (the ordinary "dilute" reagent), and 200 cubic centimeters of water, in a flask with an air condenser (a long, straight glass tube passed through the stopper) for three hours; or the flask is fitted with a return Liebig condenser, or one of similar type, and kept boiling by a direct flame for one hour and a half. The contents of the flask, after cooling, are then neutralized with sodium hydrate, care being taken *not to get it alkaline* (very faint acidity does no harm), made up to 500 cubic centimeters, and the dextrose determined by Fehling solution. By the simple formula, $C_{12}H_{20}O_{10} + 2H_2O = 2C_6H_{12}O_6$, the equivalent of starch is .9 the amount of dextrose. Experiment has shown that there is always a certain amount of decomposition in the complete hydrolysis of starch to dextrose, so that the factor .92, according to Wiley and Krug, gives more accurate results.

The diastase method, according to Wiley,¹ being practi-

¹ *Agric. Chem. Anal.*, 3, 198.

cally the Halle (Agricultural Station) method, is as follows: About 3 grams of the finely pulverized material is extracted, first with ether, and then with 10 per cent alcohol, and boiled with 100 cubic centimeters of water for 30 minutes with constant stirring, to set free the starch paste. The water lost by evaporation is replaced, and the mixture placed in a water bath at 55–60° C. When the liquid has cooled to the water-bath temperature, 10 cubic centimeters of fresh malt extract are added, and the whole is digested for an hour with occasional stirring. The mixture is then digested for 15 minutes with another 10 cubic centimeters of malt extract. This treatment is again repeated. The mixture is then filtered, made up to 250 cubic centimeters, and 200 cubic centimeters is hydrolyzed according to the Sachsse method, two hours being sufficient for the acid hydrolysis on the water bath. The malt extract is made by soaking 100 grams of fresh malt in 100 cubic centimeters of cold water for two or three hours, and filtering; or, as recommended by Wiley for a more permanent extract, 1000 grams of finely ground "green" (not kiln-dried) malt is mixed with a liter of glycerine and allowed to stand for eight days with frequent shaking. It is then filtered under pressure, and again by ordinary filtration. This extract is said to keep well.

As malt extracts always contain some reducing sugars, blank Fehling tests must be made to determine the necessary correction to be applied. Hibbard's modification of the diastase method for rapid work is as follows: Previous extraction with ether is omitted. Enough of the mixture to contain at least .5 gram of starch is placed in a flask with 50 cubic centimeters of water and about 2 cubic

centimeters of malt extract, and heated to boiling with frequent shaking to prevent pasting. The mixture is boiled one minute, cooled to 60° C., and 2 or 3 cubic centimeters of malt extract again added. It is then heated gradually to boiling, taking 15 minutes, cooled, and tested with iodine for any unchanged starch. If starch is shown, the operation must be repeated. The rest of the procedure is as in the method previously described.

In any method where diastase is used as a solvent, the residue from the filtrate of the malt-converted liquor should be examined for unconverted starch.

Wiley recommends the use of *pepsin* in conjunction with malt extract as a solvent of the proteid matter which incloses the starch granules and interferes with the solution of the latter.

Optical and Reducing Properties of Hydrolyzed Starch Products.—It is impossible to polarize pure starch, as it forms a colloidal solution which is practically opaque, except in very dilute solutions; the liquid solutions of some starches, so called, being really of starch which has undergone an incipient hydrolysis in the process of extraction from the plant tissues, or in the treatment for polarizing. Pure starch can be shown theoretically to have a specific rotation of about 202°. It gives no reduction with Fehling solution. If starch is hydrolyzed with *acids*, there is a regular decrease in the rotation, and a reducing power is developed which shows a corresponding increase as the rotatory power decreases, till the specific rotation becomes practically constant at 52.7 and the cupric-reducing power becomes 1.00. If the heating is prolonged and the hydrolyz-

ing acid of considerable strength, these exact figures are not obtained, owing to a small amount of decomposition products which is formed.

Investigations made in the laboratory of the Massachusetts Institute of Technology¹ have shown that a definite relation exists between the specific rotation and the cupric-reducing power of acid-hydrolyzed starch products at every stage of conversion; in other words, strong experimental evidence tends to prove that the cupric-reducing power of any normally acid-hydrolyzed starch product can be predicted, if its specific rotation is known. The relation of the cupric-reducing power plotted from actual experimental results shows a curve which cuts the 0 and 1.00 points, expressing the cupric-reducing values, very nearly at rotations of 202° and 52.7° respectively.² This means that all acid-hydrolyzed products of the same specific rotation have the same composition, and consequently, the determination of specific rotation is a rapid means of identifying such (pure) products. A similar law of relation has been proved by Brown and Morris to exist in all diastase-hydrolyzed starch products. In this latter case, the law of relation is represented in plot by a straight line, the cupric-reducing values of 0 and .62 being at points of specific rotation of 203° and 138° respectively; the value .62 is the cupric-reducing power and 138° the specific rotation of pure maltose, which is the final product present in malt (diastase) converted starch.

¹ *J. Am. Chem. Soc.*, 18, 869; *ibid.*, 25, 1003. Wiley pointed out a similar relation in the case of commercial glucose as early as 1882 (*Proc. A. A. S.*, 30, 65).

² See diagram on page 198.

Methods of Analysis of Acid-hydrolyzed Starch Products.
 —As already stated, acid-hydrolyzed starch products can be considered to be composed of three primary constituents, dextrose, maltose, and dextrin. These constituent bodies cannot be isolated from each other except by a tedious and complicated procedure impracticable for most commercial analysis. In consequence, an ingenious indirect method has been worked out by which the proportions of the primary constituents are calculated from the results of three determinations, — the *total solids*, the *specific rotation*, and the *cupric-reducing power*. The acid-hydrolyzed product being pure, evidently, if the per cents of dextrose, dextrin, and maltose are expressed (as decimals) by D , Δ , and m respectively, the *composition of the carbohydrate substance* will be expressed by the following equation :

$$D + m + \Delta = 1. \quad (1)$$

As the specific rotatory power of dextrose is 52.7, that of maltose 138, and dextrin 203, the specific rotatory power of the hydrolyzed product is given by the following :

$$52.7 D + 138 m + 203 \Delta = \alpha_D. \quad (2)$$

Two of the constituents, dextrose and maltose, give reduction by the Fehling method, maltose having .62 the reducing power of dextrose. This stable dextrin is usually considered to be non-reducing (although the researches of Brown and Millar¹ have recently shown that the corresponding and probably identical dextrin of diastase conversion has a cupric-reducing power of about .03).

¹*J. Chem. Soc.*, 75, 322.

The following equation would then express the cupric-reducing power of the acid hydrolyzed product:

$$\kappa = D + .62 m. \quad (3)$$

From the three independent equations, the values of D , m , and Δ can be determined.

Total Solids.—In order to determine the optical and reducing constants, it is necessary to know the exact amount of pure carbohydrate in the solution analyzed. As the amount of organic matter, other than carbohydrate, in starch products is, as a rule, negligible, the total solids, less the mineral matter, which can be determined as ash, represent the total products of hydrolysis.

As already stated, it is practically impossible to determine the total solids of a saccharine solution with any accuracy by the ordinary methods of drying, and in fact no reliable method at all was known till comparatively recently. On this account, it had become customary for glucose and brewery chemists to use the density of the solution as a measure of the amount of dissolved carbohydrate, it being assumed that the density influence of the carbohydrate constituents is identical with that of cane sugar; that is, if the solution has an approximate concentration of 10 per cent, every gram of carbohydrate present in 100 cubic centimeters of solution at 15.5° C. increases the density (referred to water at 15.5° C.) by .00386. The solutions must approximate 10 per cent, as both the density factor and specific rotatory power vary with the concentration.

By this method, first introduced by O'Sullivan in 1876,¹ the amount of total solids of a solution of pure carbo-

¹ O'Sullivan's original factor was .00385, it being subsequently changed by Brown and Heron to .00386.

hydrates resulting from starch hydrolysis was assumed to be given by the formula, $w = \frac{d - 1.000}{.00386}$, this equation being correct for 10 per cent solutions of *cane sugar*, within about .1 per cent. If mineral matter be present, as it usually is in small amount, .008 for every gram of ash obtained from 100 cubic centimeters of the solution must first be deducted from the density actually obtained in order to determine the density due to the carbohydrate alone. The density is determined most accurately by the "pycnometer," although the "Westphal balance" is sufficiently accurate in careful hands for most work. In commercial analyses in general factory control, the Brix spiudle can be used, this giving the per cent of total solids directly without calculation, except for the mineral matter present, which must be corrected for.

Determination of Density.¹ The Westphal Balance. — The essential parts of this apparatus are a glass hydrometer sinker counterpoised on a delicate balance. The weights are in the form of riders, which are designed to be hung on the balance arm which carries the sinker, the other arm serving to carry the fixed counterpoise weight (*K*) which balances the sinker in air. The weighing arm (*II*) is graduated into *tenths* by deep notches cut in the beam, each notch being numbered according to the number of tenths of the distance from the center to the end knife-edge it represents. The largest rider is 10 tenths, the next 9 tenths, and so on.

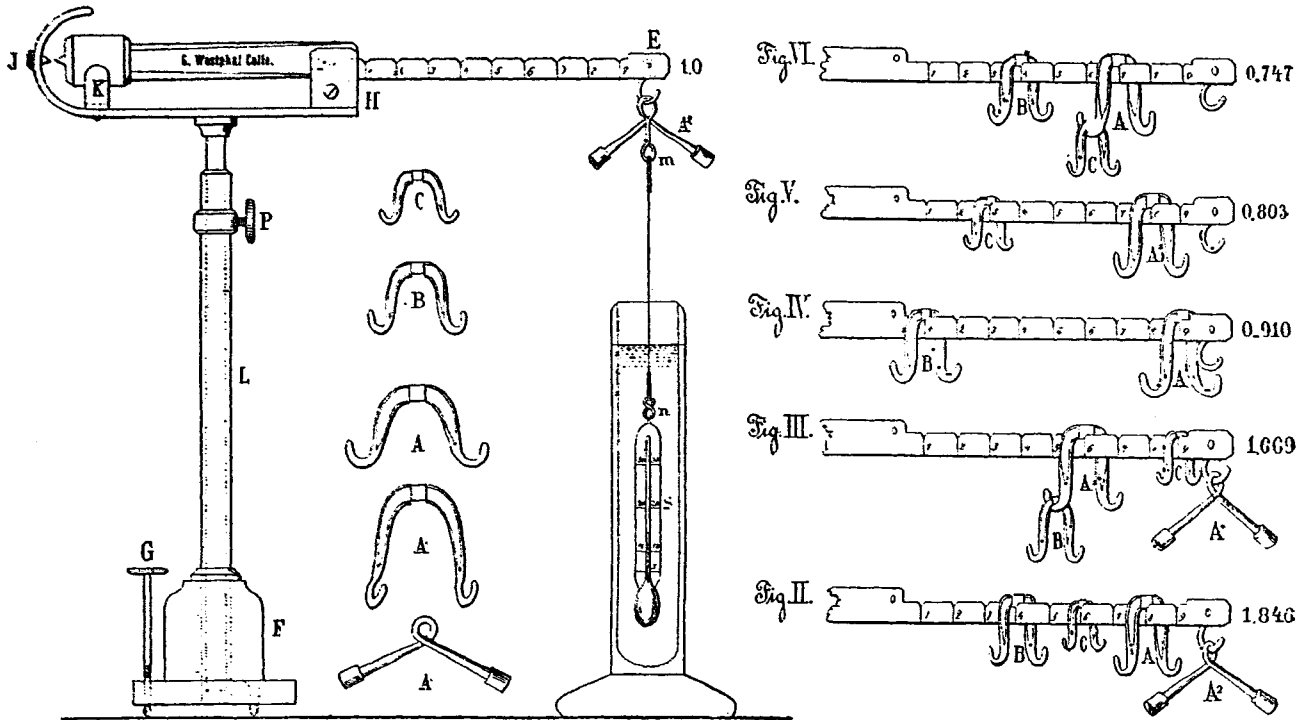

FIG. 30.—DETAIL OF WESTPHAL SPECIFIC GRAVITY BALANCE AND ILLUSTRATION OF MANNER OF READING.

in water at the standard temperature, usually 15.5°C . The glass sinkers are commonly made so that they displace exactly 5 grams of water at the standard temperature, and with the platinum suspending wire and hook weigh exactly 10 grams, so that they are interchangeable. In most types a thermometer is inclosed in the sinker.

The other rider weights are decimals of the largest, weighing respectively .5, .05, .005 grams, each rider being readily distinguished by its size. As a large rider (*A*), placed on the stirrup hook, just balances the buoyancy of the water displaced by the sinker at standard temperature, showing a density of 1.0000, evidently the sinker immersed in a liquid of a density of 1.1000 will be balanced by the addition of the .5-gram rider on the stirrup hook, an increase of .01 in the density requiring the .05-gram rider to be placed on the stirrup hook,—and so on. So, too, it will be clear that the 5-gram rider in any notch on the beam represented by the number of its graduation, *n*, will balance the buoyancy of the liquid caused by any increase in density corresponding to $.1 n$, the .5-gram rider (*R*) any increment in density corresponding to $.01 n$, etc. For instance, if the balance is in equilibrium when the sinker is immersed in a liquid at 15.5° , and one 5-gram rider is on the stirrup hook, another 5-gram rider in the beam notch marked 1, the .5-gram rider in notch marked 4, the .05-gram rider (*C*) in notch marked 6, and the .005-rider (not shown in cut) in notch numbered 8, the density of the solution is 1.1468. Thus, *by noting the numbered position of each rider on the beam, and its size, the density can be read off directly without calculation.* (See other illustrations of readings in Figure 30.)

In using the Westphal balance, the sinker (S) is first carefully balanced in air, by adjusting the leveling screw (G) in the balance foot. The sinker is then immersed in the liquid, care being taken to remove any adhering air bubbles—most conveniently by means of a fine wire. Care should be taken also to have always the same length of supporting wire of the sinker immersed in the liquid; just how much being determined once for all by calibrating the balance with pure water at the standard temperature, and marking a line on the adjustable supporting post (L) of the balance, and another on the glass cylinder used to contain the liquid. This latter mark will show the height that the cylinder must always be filled to give the proper immersion of the wire when the height of the balance is adjusted to the mark on the post by the set screw P . The Sartorius type of Westphal is so marked by the maker.

A well-made Westphal balance should be precise to .0005 gram, and consequently should have the same care as any other analytical balance.

Determination of Density by the Pyknometer.— This is the most precise method. There are many forms of pyknometers, but most of the ordinary types used for determinations of densities by weighing 20 cubic centimeters or more of solution are practically identical in principle,—light flasks which are devised so that they can be accurately filled to a fixed volume within an error represented by the difference in weight of about .001 gram, the point of level of the liquid filling the pyknometer being read off in a capillary tube. Usually there is a thermometer attached, and a tightly fitting cap for the capillary tube, so as to

retain any water expanding out of the flask during weighing.

The method of using the pycnometer is as follows: The weight of the carefully cleaned and dried apparatus is taken, or it is balanced with a tare weight. The pycnometer is then filled with freshly boiled water at a temperature somewhat lower than the standard, and then allowed to warm up till the thermometer shows that the standard temperature is reached, or, for greater accuracy, brought to the standard temperature by immersion in a cold-water bath. The liquid which has oozed from the capillary is then carefully wiped off, and the opening closed with the glass-cap (or in some forms of pycnometer, the level of the liquid in the capillary is merely brought to a mark). The pycnometer is again weighed. In this manner the weight of water the pycnometer contains at standard temperature is obtained once for all, this expressing the *volume in Mohr cubic centimeters*.

The weight of any solution contained by the pycnometer at standard temperature, obtained in the same way, divided by the volume, gives the density relative to its volume in *Mohr cubic centimeters*. *Absolute* densities (referred to volumes in *true* cubic centimeters at 20° C.) can be calculated by the formula, $d_{20}^{20} = \frac{w' D_{20}}{w}$, where w' is the weight of solution and w the weight of water, both taken at 20°, D_{20} being the density of water at 20°.

As the air buoyancy has practically the same influence on both weights, reduction to vacuo is unnecessary for ordinary-sized pycnometers.

A very convenient pycnometer, used by the author in

the laboratory of Professor J. M. Crafts, is shown in the following sketch :

The pyknometer is designed to be used with a constant temperature bath, the reference point by which the volume is measured being marked on the funnel stem. The method of using is by filling the flask through the funnel tube, and after bringing the contents to the standard temperature by means of the water bath, gently inclining the apparatus so that the liquid dropping out of the capillary sinks to the mark *A* on the funnel stem.

The pyknometer can then be placed upright on the balance pan and weighed at convenience, as there is ample room for the liquid to expand from any change in ordinary laboratory temperature, without spilling out of the pyknometer.

As stated, it is customary in commercial work to determine the constituents of both malt and acid converted starch products, such as beer worts, commercial "glucose," and grape sugar, by determining the carbohydrates from the density by means of the factor .00386. Obviously, the true specific rotatory and cupric-reducing constants are in the ratio of $\frac{F}{.00386}$ to the values obtained by this method,

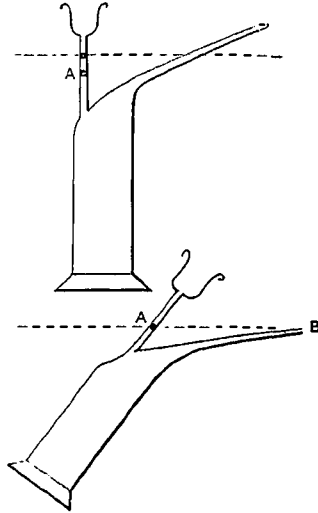

FIG. 31.—DIAGRAM OF CONVENIENT PYKNOMETER.

where F represents the true density factor of the product examined. If the primary constituents are calculated by the equation already given, the percentages will be practically correct, *provided the optical and reducing constants used are based on the factor .00386*. For instance, the specific rotation of maltose is 138° , but as its density factor for a 10 per cent solution is .00393, its specific rotation for the factor .00386 (symbolized, $[\alpha]_{D_{386}}$) is $\frac{386}{393} \times 138$, or 135.5° .

The equations with these constants become :

$$D + m + \Delta = 1. \quad (1)$$

$$53.0 D + 135.5 m + 195 \Delta = \alpha_{D_{386}}. \quad (2)$$

$$D + .61 m = \kappa_{386}. \quad (3)$$

(The per cents are given as decimals by these equations.)

In 1897 Brown, Morris, and Millar published curves giving the density factors of most of the common hexose carbohydrates and starch derivatives of malt conversion, calculated from results obtained by evaporation of solutions in vacuo over phosphorus pentoxide. Similar work was done in 1889 on acid-hydrolyzed starch products at the sugar laboratory of the Massachusetts Institute of Technology, so that the true density factors are now well established for pure products of acid and diastase converted starch.

As, however, the density factors differ with the *degree of conversion*, and as this latter is measured most conveniently and rapidly by the *specific rotatory power*, it is most convenient to obtain first this value as expressed by the factor .00386 in calculating the absolute value.

Determination of Specific Rotatory Power. The density of the filtered solution of the hydrolyzed product (which should approximate to 1.04) is determined as accurately as possible at 15.5°. The solution is then polarized in a 2-decimeter tube, most conveniently in a quartz-wedge saccharimeter provided with a yellow light screen, either of bichromate solution or a piece of brown glass. The saccharimeter reading is multiplied by the "light factor" of the instrument for hydrolyzed starch (discussed in a later chapter) which is .345. The saccharimeter reading multiplied by this coefficient, which is the equivalent of one saccharimetric division in angular degrees of rotation of the plane of polarization of the standard yellow ray, gives α of the equation:

$$\alpha = \frac{a\tau}{l\omega}$$

Since ω in 100 (Mohr) cubic centimeters¹ = $\frac{d-1}{.00386}$, the equation becomes,

$$\alpha_{D_{390}} = \frac{.345 R \cdot 100(.00386)}{2(d-1)}$$

Expressing the constants by a four-place logarithm, the calculation for $\alpha_{D_{390}}$ becomes:

$$\alpha = \log. R + \text{colog. } (d-1) + 8.8234 - 10.$$

The density, especially in acid-hydrolyzed products, must be corrected for the influence of the dissolved mineral matter. This is done by taking 20 cubic centimeters of the solution, evaporating practically to dryness in a tared platinum dish, and then incinerating in a "low temperature" muffle, a little vaseline being added to prevent excessive swelling of the coal. The ash is weighed to .0001 gram,

¹ The density standard is 15.5°C, the polarimeter, 20°C.

and .008 is deducted from the density for every gram present in 100 cubic centimeters of the original solution.

For factory control in the manufacture of glucose, and in commercial work where great accuracy is not needed, the Brix spindle can be used, the reading of which giving *per cent* of solids (grams in 100 *grams*) must be applied in the formula, $\alpha = \frac{100 a}{l p d}$, the Brix reading being taken as p ; d being found from the Brix comparison table. Since the density at which the optical and reducing constants have been calculated is approximately 1.04, it is clear that an error of .1 Brix (about .0004 in density) makes an error of 1 per cent in the result. Hence the ordinary Brix spindle is not sensitive enough for highest accuracy. In commercial glucoses, the influence of the mineral matter also lowers the result from 1 to 2 per cent. The uncorrected values are, however, sufficiently approximate to be valuable for commercial work in determining the composition of the product. The calculation in this case becomes:

$$\log. R + \text{colog. } p + \text{colog. } d + 1.2367.$$

The *true specific rotation*, for the actual weight of 1 gram of carbohydrate in 1 true cubic centimeter, can be calculated from $[\alpha]_{D_{386}}$ by multiplying by $.99802 \frac{F}{.00386}$, the first factor being that for conversion of the values from concentrations representing densities taken at 15.5°, referred to Mohr cubic centimeters at 15.5°, to densities at 15.5° referred to true cubic centimeters. The factors for conversion of $[\alpha]_{D_{386}}$ to true specific rotatory powers of absolute weights of carbohydrates are given in the following table:

DENSITY FACTORS FOR REFERENCE TO ACTUAL WEIGHTS OF
 AMYL-HYDROLYZED STARCH PRODUCTS IN 100 TRUE CUBIC
 CENTIMETERS OF SOLUTION

ρ (g./cc.)	Density (d_{20}^{20}) Lobes (15.5)	Logarithm of conversion factors ¹
55	0.003837	9.9965
60	0.003844	9.9973
65	0.003850	9.9980
70	0.003857	9.9988
75	0.003864	9.9996
80	0.003870	0.0002
85	0.003877	0.0010
90	0.003884	0.0018
95	0.003890	0.0024
100	0.003897	0.0032
105	0.003904	0.0040
110	0.003911	0.0048
115	0.003918	0.0056
120	0.003925	0.0063
125	0.003931	0.0070
130	0.003938	0.0078
135	0.003945	0.0085
140	0.003951	0.0092
145	0.003958	0.0100
150	0.003965	0.0107
155	0.003971	0.0114
160	0.003978	0.0121
165	0.003985	0.0129
170	0.003991	0.0136
175	0.003998	0.0144
180	0.004005	0.0151
185	0.004011	0.0157
190	0.004017	0.0164
195	0.004023	0.0170

In conversion of κ_{386} to κ absolute, since the cupric-reducing power of pure dextrose, taken as 1.00 for the factor .00386, is .9915 in absolute value, it is necessary to add the cologarithm of this number, or .0037, to the logarithm of the conversion factor in calculating the reducing power in terms of that of the equivalent weight of dextrose as unity.

Determination of the Cupric-reducing Power.—In determining the cupric-reducing power of hydrolyzed starch products, the original solution must be diluted sufficiently to give about .2 gram of copper. With the Defren method, this means, in most cases, a dilution of the original solution to $\frac{1}{20}$ of its original concentration; taking, for instance, 25 cubic centimeters of the original solution, and diluting to 500 cubic centimeters. Since the original weight of carbohydrate is determined from the amount in 100 cubic centimeters, and the volume of the solution taken for the Defren-Fehling test is 25 cubic centimeters, the copper reduced by the amount of carbohydrate in the original solution is obtained under these conditions by multiplying the actual weight by 80.

The calculation is expressed by the following equation :

$$\kappa = \frac{C\rho\epsilon}{\frac{d-1}{F}}$$

where ρ is the ratio of the concentration of the original solution to that of the solution diluted for the Fehling test, ϵ is the "dextrose equivalent" of the copper as given by a table calculated for the method used, and C is the weight of copper (or its oxide) actually weighed. The actual weight of carbohydrate in 100 cc. of solution is

obtained from the density factor, either using the value, .00386, as has been customary in commercial work, or the true factor obtained from the determination of specific rotary power as described.

Diastase-converted products, such as beer worts or malt products, are determined in an analogous way, but as *dextrose* is usually absent, the equations expressing the primary constituents are modified accordingly. Moreover, as the malt itself contains considerable quantities of cane and invert sugars, corrections must be made for these carbohydrates when malt extract is present in appreciable quantity, and the determination of the actual carbohydrate constituents becomes a complicated one.¹

Determination of the Constitution of Hydrolyzed Starch Products from their Specific Rotatory Power.—As already stated, the large amount of experimental data on acid-hydrolyzed starch products obtained under many diverse conditions of hydrolysis points to the important conclusion that, in acid conversion, products of the same specific rotatory power have the same composition, irrespective of the source of the starch, the nature or amount of the hydrolyzing acid, or the temperature conditions, these influencing the *rate* of hydrolysis only.

This constant relation holds true only with products of the starch itself which have all been subjected to the same conditions of hydrolysis, and not to mixtures of products at different stages of conversion hydrolyzed under different conditions. Moreover, in the case of products hydrolyzed with acid of considerable strength

¹ See Moritz and Morris, "Textlook of the Science of Brewing," or Heron's article on Sugar in Thorpe's "Dictionary of Applied Chemistry," p. 669.

or at high temperature, there are always some decomposition or so-called "reversion" products formed to some extent. These introduce some error in the higher converted products. The nature and conditions of forma-

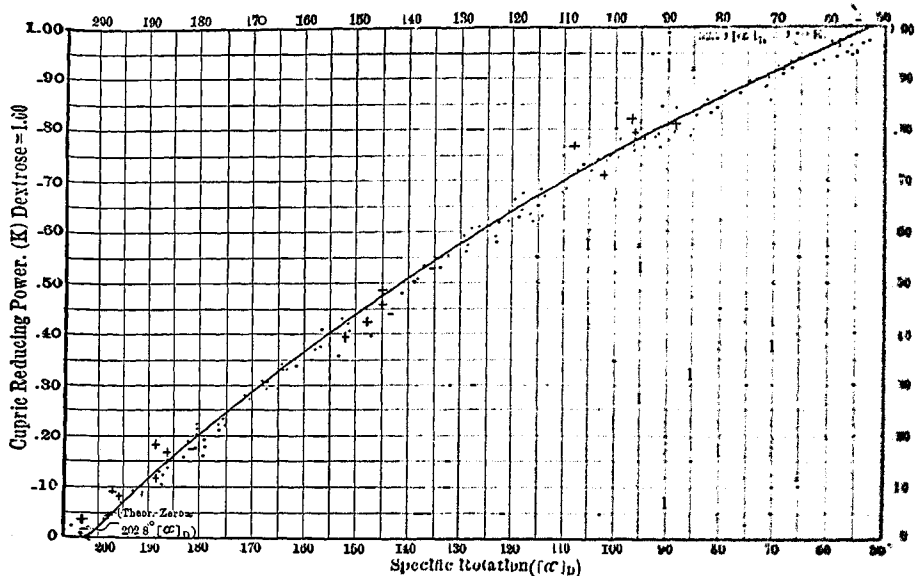

FIG. 32.—CURVE OF RELATION OF CUPRIC-REDUCING POWER TO SPECIFIC ROTATION OF ACID-HYDROLYZED STARCH PRODUCTS.¹

tion of these products, which under ordinary conditions are present only in very small quantities, are by no means thoroughly understood. In many cases, there seems to be a slight loss in carbohydrate from the breaking up of

¹ The dots and crosses represent reducing values actually obtained by experiment, the crosses being results from products separated by alcoholic precipitation.

the molecule through oxidation. As a rule, these bodies are present in negligible quantities.

Brown, Morris, and Millar have published the results of over five hundred analyses, conclusively proving that the law of constant relation between optical rotation and cupric reduction does exist in *diastase*-conversion products of starch.

The relations between optical rotation and cupric reduction of products of the two kinds of hydrolysis are graphically shown in the preceding diagram.

From the values thus obtained, by calculation by the equations given on page 192, the following curves have been plotted, which show the per cent of primary con-

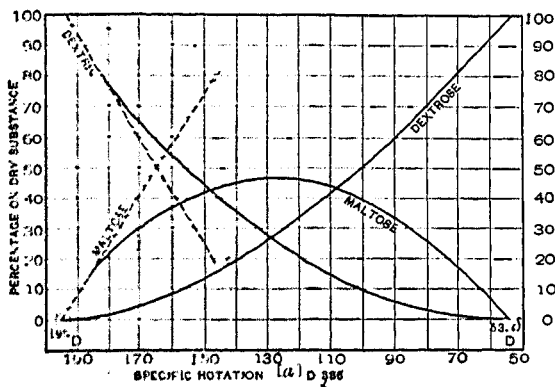

FIG. 33. — RELATION OF THE CARBOHYDRATE CONSTITUENTS OF ACID AND DIASTASE-HYDROLYZED STARCH PRODUCTS TO THEIR SPECIFIC ROTATION.

stituents in hydrolyzed starch products (calculated for the factor .00386). The dotted lines represent the products of diastase conversion (see Table No. 5 in Appendix).

From such curves the constitution of any pure hydro-

lyzed product can be determined from its specific rotatory power. In practice there are comparatively few commercial products pure enough to permit of their constitution being determined in this simple manner. In the case of commercial "glucoses," however, which contain but traces of foreign substance, this method is most valuable, not only in factory control, but for valuation of different lots of product for the purposes for which the glucose is to be used.

Manufacture of Commercial Glucose and Grape Sugar.— The word "glucose" is used to mean different things, and consequently there is considerable misunderstanding as to what is meant by the term. In Europe, especially England and France, the word is synonymous with dextrose, or "starch sugar." In America this latter product is invariably called "grape sugar," *glucose* being applied to the thick viscid sirup which is manufactured in large quantity by the partial hydrolysis of starch with acid. It is in this popular signification that *glucose* is used here. As used in a previous chapter, it is employed, as in organic chemistry, as a class term to designate a group of hexose sugars.

The manufacture of glucose is carried on on an enormous scale in this country, in conjunction with that of starch and numerous valuable by-products, which latter will only be alluded to in the following description.¹

In the manufacture of "glucose" two conditions are imperative: (1) The amount of dextrin must be sufficient to prevent the separation of crystallized sugar when the

¹ Taken from a paper on the manufacture of brewing sugars, written by the author and George Defren for the North British Federated Institutes of Brewing of Manchester, England, in 1899.

product is concentrated to 45° Bé., or about 84 per cent.

(2) Under similar conditions dextrin should not separate out. These conditions limit the conversion stages to those represented by that part of the diagram (Figure 33) lying approximately between the rotation figures, 150° and 100° . Commercial glucoses in the market vary in polarization from $[\alpha]_{D_{386}} = 145^{\circ}$ to 120° . As the greatest consumption of glucose is in the manufacture of candies, jellies, and sirups, its composition has been determined by the demands of these trades. The use of glucose in beers, extensive as it is, takes a very small proportion of the total output. On this account there are practically two grades of glucose on the market, leaving out of consideration goods which differ only in concentration: mixing (sirup) glucose, with a conversion of $[\alpha]_{D_{386}} = 120^{\circ} - 130^{\circ}$; and confectioners' goods of $[\alpha]_{D_{386}} = 130^{\circ} - 140^{\circ}$. The best confectioners' goods are commonly about $[\alpha]_{D_{386}} = 135^{\circ}$. There is by no means a rigid standard, however; in fact, many manufacturers grade according to the perfection of refining, the clearer, whiter glucose, independent of its conversion, being specially treated for confectioners' use. Jelly goods differ from mixing glucose merely in concentration, although imperfectly refined candy glucose is often worked up into this grade, as a slight turbidity or tint is of no consequence in jelly manufacture. Mixing glucose is the kind usually bought by the brewer. The composition may vary through wide limits, the proportion of dextrin, for instance, varying in extreme cases about 100 per cent. In short, the commercial grading of a glucose is no criterion of the relative proportion of dextrose, maltose, or dextrin.

Space permits only the most superficial description of the manufacture of glucose. In general the process consists of three parts: (1) separation of the starch; (2) conversion; (3) refining. (The diagrammatic scheme (Fig. 34) will assist in following this description.) All kinds of what is known as No. 3 or No. 4 corn (maize) are used. This

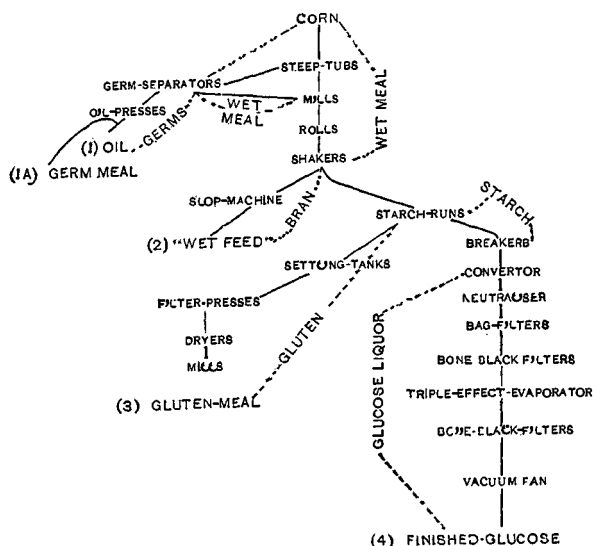

FIG. 34.—DIAGRAMMATIC SCHEME OF THE MANUFACTURE OF COMMERCIAL GLUCOSE.

corn is taken from the cars or the elevator of the works to the steep tubs, which hold 2000 bushels or more. In steeping, water at 150° F. is used at first, then the steep is allowed to cool till a temperature of about 90° F. is reached. Sulphurous acid is used to prevent putrefaction and assist softening. The steeping lasts from three to five days. The separation of the starch consists of (1) grinding the

wet grain mixed with water, and softened by steeping; (2) separating the starch grains from the woody fibre and germ by washing through sieves of bolting cloth, rapidly shaken; (3) settling out the starch from the gluten by subsidence while passing over gently inclined runs ("tables"). The grinding is done so that the starch grains are set free, but not ruptured. The germ is removed separately in many factories. This is accomplished by coarse grinding and running the grain mixed with much water through a long trough, or into a tank, the mass being agitated slowly. The germ which floats is carried off by one channel, the rest of the grain by another. This separation of the germ is an important improvement, since the oil which is contained in it (about 15 per cent) can be readily obtained as a by-product,¹ and the quality of the glucose is much improved by its removal. The grain from the separators is ground and washed on the sieves ("shakers") in the usual manner, and the separated liquor sent over the runs. The thin, highly diluted gluten is allowed to settle, pumped through filter presses, and the dried cake, which contains over 30 per cent of protein, sold for cattle feed.

The starch collected on the runs, and containing about 50 per cent of moisture, is now mixed with water to a thick cream of about 20° B \acute{e} , preparatory to conversion. Conversion is carried on in large copper boilers at a steam pressure of 30 pounds, hydrochloric acid being the converting agent, the amount used being about .0006 of the weight of the starch.

¹One of the important uses of corn oil is in making "rubber" floor matting. Vulcanized corn oil makes an excellent rubber substitute for such purposes. It is also an adulterant of genuine rubber.

In some factories sulphuric acid is still used as the hydrolyzing acid. In the manufacture of candy goods and certain hard sugars it seems to have some advantages.

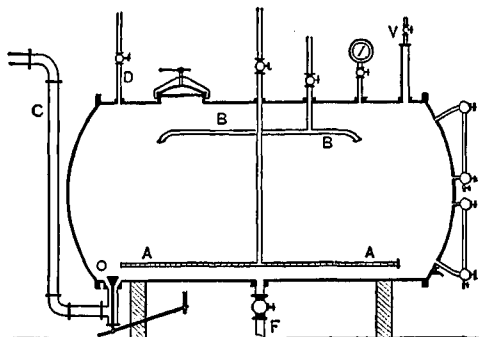

FIG. 35.—SECTION OF CONVERTER.

- | | |
|--|----------------------------|
| <i>A.</i> Perforated steam pipe. | <i>D.</i> Acid pipe. |
| <i>B.</i> Starch liquor pipe. | <i>F.</i> Washout pipe. |
| <i>C.</i> Discharge pipe to neutralizer. | <i>O.</i> Discharge valve. |
| | <i>V.</i> Air-vent pipe. |

(From Thorp's "Outlines of Industrial Chemistry.")

Oxalic acid has been used for the manufacture of fine candy glucose. In the manufacture of grape sugar a much larger proportional amount of acid is used, in some cases up to 1 per cent or more of the weight of starch.

The point of complete conversion is usually controlled by the disappearance of the dextrin precipitate when the liquid is poured into alcohol.

In glucose conversion the acid is mixed with about fifty times its bulk of water, and is run into the "converter." Steam is then turned on till a pressure of 30 pounds is obtained. This pressure is maintained while the starch milk is pumped in, which takes about half an hour. Heating is continued after this for 40 minutes or more. "Dirty" starch, containing much gluten, increases the time of conversion 10 minutes or more. The degree of conversion is entirely controlled by iodine tests. By daily practice, workmen become quite expert in making these tests, yet from

week to week there is apt to be considerable variation in composition when tests are not checked by chemical control by determining the specific rotation of the liquids from the bone-black filters.

The refining process is, in general, similar to that of cane sugar. The analogy is quite close in the case of the solid grape sugars. In the case of glucose, however, there is a radical difference of principle which must not be overlooked. In the refining of glucose the purification must be carried to great lengths, at least as far as color and appearance are concerned. All bodies affecting these characteristics must be absolutely removed from the liquid, or bleached in it, since there is no mother liquor in which they can be deposited, as in the case of a crystalline sugar. On this account the refining of glucose is a much more delicate process than that of sugar.

Neutralization is an important part of the refining, as on the thoroughness with which this is done depends how successfully the albuminoids, calcium,

and iron salts are removed. As soon as the conversion is completed the liquid is blown out into the "neutralizer," where the alkali, usually sodium carbonate, is added. In

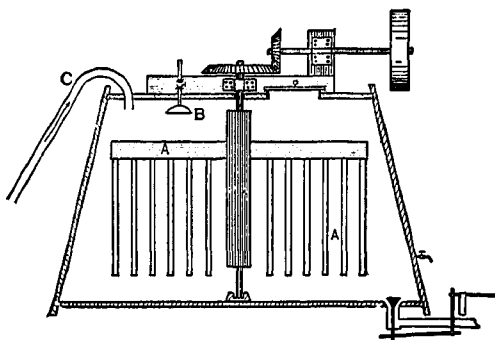

FIG. 36.—SECTION OF NEUTRALIZER.

A. Revolving stirrer.

B. Sprinkler pipe for alkaline neutralizing liquid.

C. Discharge pipe from converter.

(From Thorp's "Outlines of Industrial Chemistry.")

many factories it is the practice to cool the liquids considerably before neutralizing, but this seems unnecessary when the alkali is added properly. The liquid when neutralized should show only the acidity caused by carbon dioxide or the weakest vegetable acids. The properly neutralized liquid is clear and of a bright amber color, but contains large flocculent masses of coagulated gluten, which, in a test tube of ordinary size, form a layer about half an inch thick. When the proper point of neutralization is attained, this layer is greenish drab, owing to the precipitated iron.

As in sugar refining, the precipitated matter is removed by bag filters, which are often supplemented by a press filtering. In the case of highly refined glucoses, precipitants are sometimes used, such as alum. The tendency seems to be for manufacturers not to push this part of the refining to greatest advantage, but rather to depend on a liberal use of bone black to do much of what it would seem could be accomplished by less expensive means in preliminary clarification. The bone-black treatment is quite complicated, not only in the details of filtering, but in the preparation of the black. Since the slightest trace of alkali in contact with hot liquor will produce a brown stain of caramel, removable only to a limited extent by bone black, the black itself must be freed from all traces of ammonia or caustic lime by a careful "tempering" with hydrochloric acid or some similar treatment, and subjected to a careful washing to remove soluble salts of iron and calcium. The glucose liquors are, as a rule, put over the bone black twice: first at their original concentration, about 18° Bé.; and again after concentration to 28–30° Bé., the denser

sirup going over the freshly tempered black. The re-vivifying of the black is carried out on lines similar to those of cane-sugar refining.

The "heavy liquor" goes directly from the filters to the vacuum pan in most modern factories. Formerly a preliminary filtration was necessary to remove the calcium sulphate which separated out, but with the use of hydrochloric acid conversions and neutralization with soda this is avoided. In the final concentration sulphites are added in amounts varying from .008 to .050 per cent SO_2 .

The function of these sulphites is as follows: (1) to prevent oxidation and consequent coloration in the final concentration due to formation of caramel-like bodies, and sometimes ferric salts; (2) to bleach; (3) to prevent fermentation of the less concentrated finished products, as the thinner mixing sirups; (4) in candy goods, as a preventive of oxidation in the candy kettle. Confectioners' goods are more heavily "doped" with sulphites than others.

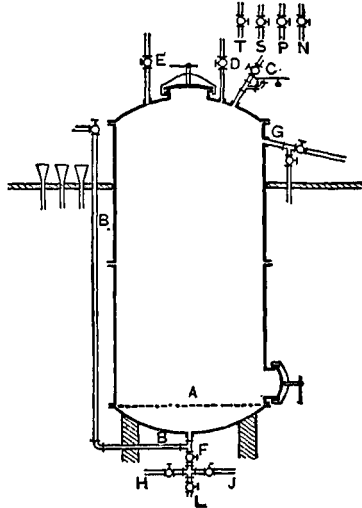

FIG. 37. — SECTION OF BONE-BLACK FILTER.

- A. Perforated false bottom on which bone black rests.
 - B. Discharge pipe for filtered liquor.
 - C. Entrance pipe for liquor.
 - D. Steam pipe.
 - E. Air-vent pipe.
 - F, H, I, J, K, L, M, N, O, P, Q, R, S, T, U, V, W, X, Y, Z. Steam, wash-water, and sewer connections.
 - G. Overflow pipe for washing out in reverse direction.
 - T, S, P, N. Tank connections, coupled by hose to C.
- (From Thorp's "Outlines of Industrial Chemistry.")

The refining for the making of ordinary commercial grape sugar, which is a waxy concrete of the hydrated dextrose, $C_6H_{12}O_6 \cdot H_2O$, and partially hydrolyzed compounds, together with some products of decomposition is practically identical with that of glucose. The concentrated sirups are drawn off into pans or barrels and allowed to solidify, a "seed" of crystallized sugar often being added to facilitate crystallization. *Anhydrous* grape sugar is made in a similar way from a sirup which is refined at lower concentrations throughout the process in order to obtain a purer product. In this case the "seed" is selected with the greatest care from absolutely pure anhydride, all hydrated crystals being scrupulously excluded. The crystallization is complete in about three days, when the sugar is purged in centrifugals. The purged liquors are often worked up into the "climax" sugars, a dark product used by brewers. These sugars also are often put on the market as "chips." Glucose sirups are usually made at five concentrations: 41° , 42° , 43° , 44° , 45° B \acute{e} . Mixing goods are usually finished up at 41° B \acute{e} . The higher concentrated products are confectioners' or jelly goods, the former being characterized by greater perfection of refining and a large amount of sulphites.

As to the manner of taking concentration determinations, the glucose manufacturers do not use the same scale as the sugar refiners, who employ Gerlach's modification. The glucose scale is practically identical with that used by the alkali manufacturers, and has the following conversion formula for the density: $d = \frac{144}{144 - \text{B}\acute{e}}$. Owing to the great viscosity of glucose, the readings are taken, not at the

standard temperature of the instrument (60° F.), but at 100° . The slightly warmed glucose is poured into a cylinder, preferably of glass, which is placed in a water bath at 100° F. At the end of half an hour or so, the glucose will have reached the temperature of the bath, and the air bubbles will have escaped. A Baumé spindle, reading to fifths, is then cautiously lowered into the glucose and allowed to come to equilibrium, which in the more viscous samples takes some minutes. With care the determination can be made on a Westphal balance. All samples of glucose should be tested for density, as the viscosity in goods of different conversions varies to a marked degree. A low-converted sample of moderate density will apparently have much more "body" than a high-converted glucose much more concentrated.

As, apart from concentration, the quality of commercial glucose is largely judged by its appearance, it will be interesting to consider briefly some of the turbidities and colorations of the commercial products, their causes, and actual influence on the quality of the glucose. A well-refined glucose is practically colorless and clear. If a white glass cylinder is filled with glucose, the color of the sample can be seen, as well as any turbidity. If the color is a pure white, the sample is dyed, as can be proved by exposing it to the light for a few days, although this coloring is rarely done so well that a close inspection will not reveal the violet tint. As all glucoses darken slightly on exposure to the light, the color balance soon becomes disturbed, and the presence of the dye is made more evident. If no dye is present, the glucose, unless quite turbid, will show some color, usually green or yellow. These tints are almost

invariably present, and seem to be caused by traces of iron salts and vegetable coloring matters. They are of little consequence, except as indicators of the thoroughness of the refining, and, hence, of the removal of albuminoids and oil. A reddish brown discoloration is the result of excess of alkali, as a rule either through imperfect neutralization or defective treatment of bone black.

Cloudiness caused by faulty conversion, separation of dextrans in one case or sugar in the other, is in these days of rare occurrence. A smoky appearance is often caused by bone-black dust, or in some cases from iron sulphide, when a large quantity of new black is used in refining; these faulty results, of course, are from improper preparation of the black. White cloudiness is usually caused either by calcium salts or by organic growths due to fermentation. The former may be sulphate or phosphate. Sulphates in goods converted by hydrochloric acid are in the main introduced through use of impure acid, or in sulphite liquors; phosphates, from excess of "tempering acid," or incomplete washing of the black. The clouds due to fermentation, which naturally are more common in goods made in hot weather, are usually the result of storing thin liquor (in process) at too low a temperature. Of course the fermentation organisms can easily be identified by the microscope. A quick way of identification is to acidulate the sample with hydrochloric acid, when the ferment cloud remains undissolved.

Solutions of grape sugar show the same characteristic colorations and turbidities, in a greater or less degree. Usually they show caramel tints, owing to the decomposition products, especially in inferior goods.

The valuation of the solid starch (grape) sugars is practically based on their dextrose content. Whiteness of late years seems to be more of a desideratum than formerly; hence the practice of dyeing is becoming common. The principal mineral impurity objected to is iron. This is rarely present in more than traces. A delicate test for iron in sugars or glucoses is made with cochineal. Sulphites must be first removed, and the solution made neutral or faintly alkaline. If iron be present, the pure crimson of the cochineal gradually passes into violet. There are two commercial grades of grape sugar, ordinarily, "seventy" and "eighty" sugar, the numbers referring to the assumed dextrose content.

A "glucose" of high quality, made by primitive methods by conversion of the starch matter of rice or millet by malt infusion, has existed in Japan for centuries.¹ This "midzu-ame" (freely translated, "liquid candy") is a transparent, amber-tinted, viscid sirup, much resembling commercial glucose in its properties, but of course free from more than the merest traces of dextrose. In short, it is essentially a pure starch-conversion product, the composition of which can be determined from its specific rotation, analogously to such determinations of acid-hydrolyzed glucose, but by means of the equations applying to diastase conversions.

Midzu-ame, in one form or other, has long played a very important part in the domestic economy of Japan. In

¹ Yoshida, *Chemical News*, 43, 29; Skilmore, "Jinnikisha Days in Japan," 37; Wiley, *Agric. Scienc.*, 6, 57; Storer and Rolfe, *Bull. Bussey Institution, Harvard Univ.*, 3, 80; Yei-Furukawa (translation by Takaki), *ibid.*, 3, 95.

some measure it still takes the place which sugar occupies in Western nations. It is of peculiar interest, as representing an advanced development of a sweet barley wort, which must have been used to considerable extent by many communities of Europe, before the advent of cane sugar, which began to be of common use only in the sixteenth century.

Manufacturing Losses. — The first loss in manufacture occurs in the soluble matter which is in the liquors drained off from the steep tubs. Practically no starch is lost, although a trace is found in the steep water, from occasional broken grains, but there is a considerable loss of valuable food materials,—carbohydrates, oil, and albuminoids. In many places it has been found profitable to recover this material by evaporating the steep waters in a multiple-effect to a thick sirup, and adding this to the gluten meal or other by-products used as cattle feed. The steep waters contain 5 to 6 per cent of this soluble food matter, and, moreover, make an offensive sewage if allowed to run into a stream.

The corn itself is graded largely on the moisture it contains. According to Archbold, the average composition of "No. 4" corn, the kind usually used in starch and glucose manufacture, is:

Oil	5.20	per cent
Carbohydrates (Starch, 54.8 per cent)	71.22	
Albuminoids ("Gluten")	10.46	
Ash	1.52	
Water	11.60	

The next loss of starch occurs in the bran, or "wet feed," the amount found here being a measure of the efficiency

of the removal of the starch from the cells of the grain in the mechanical separations, and incidentally of the steeping.

Determination of starch in the gluten liquors, passing off from the "runs" or "tables" for depositing the starch, shows the amount passing away in the gluten. This may vary considerably according to the efficiency of the steeping, and also very largely to the skill of the "paddlers," workmen who keep the surface of the deposited starch clean, and the stream of starch and gluten flowing slowly and evenly down the runs. These men prevent the partially coagulated gluten from accumulating at any point, and remove the occasional accidental obstructions which effect serious loss of starch by causing currents to cut into the deposited mass. The starch lost in the gluten liquors may amount to from 20 to 70 pounds per 1000 gallons. This, however, is saved in the by-product (gluten meal), and to some extent is necessary to facilitate the filtering in the gluten filter presses.

With the exception of a small amount of starch possibly passing into the germ meal, the only other losses in starch manufacture normally occur in washing, filtering, and handling the product in the kilns and packing, and are comparatively small, though unavoidable.

The mechanical losses in the conversion and refining of the glucose are practically the same as in sugar refining. The chemical losses are much less, as the glucose liquors do not hydrolyze appreciably under the conditions of refining. Aside from the slight decomposition during hydrolysis, already referred to, the only source of destruction is in the neutralizing, where portions of the hot liquor may come in contact with an excess of alkali (sodium car-

bonate) if the process is not properly carried out. In making grape sugar, a certain amount of destruction of sugar is inevitable. Special care must be taken, in hot weather, to avoid fermentation of thin liquors in process. The chemical control of the bone black is practically the same as in sugar refining.

Valuation of Commercial Corn Starch.—In general, starches are divided into three grades, alkaline or “chemical,” acid, and neutral starches, according to the reactions given with test paper. Alkaline starches are those in which caustic soda has been mixed before running on the tables, in order to make the gluten more soluble and so effect a more perfect separation. Acid starches were originally made by fermenting the gluten. Neutral starches, so called, are made by use of sulphite liquors in steeping and running the starch, the usual modern method. Ordinary starch is “thick-boiling,” making a stiff paste when a 5 per cent mixture of starch in water is heated to boiling. By suitable treatment of starch with dilute acid, at temperatures far below the bursting point of the granule, the starch undergoes a gentle hydrolysis, and becomes “thin-boiling,” although its appearance and other general characteristics remain unchanged. Textile manufacturers for years have availed themselves of this property, either by heating starch with acetic acid or other weak hydrolyte, or by allowing the moistened starch to undergo incipient fermentation. Owing to the greater penetrating power of the fluid paste, thin-boiling starches are peculiarly applicable in sizing or stiffening textiles, as a large amount of starch can be introduced into the fabric without coating the surface. Consequently the viscosity, or, as it is usually stated

in commercial work, the "fluidity," of the paste which the starch makes when mixed with water in standard proportion is an important criterion of its value for certain purposes. These fluidity tests are made in various ways, but the somewhat crude commercial methods depend on the number of cubic centimeters of a 5 per cent starch paste, made by rupturing the grains with a weak solution of caustic alkali, which will run out of a funnel through a capillary orifice in a definite period, the paste being at standard laboratory temperature, and the instrument adjusted so that 100 cubic centimeters of pure water will run out of the instrument under the same conditions. Thus, an "80" thin-boiling starch gives a paste which has 80 per cent the "fluidity" of water, measured in this way. A more accurate method of measuring fluidity is by the *Doolittle torsion viscosimeter*, which measures the angular loss in the oscillation of a torsion pendulum whose cylindrical bob is immersed in the paste. The supporting wire is first twisted, by a special device, through an angle of 360° , and the pendulum then released, the difference in reading at the end of a complete oscillation (the reading, for instance, at the end of a period of swing to the *right*, and the reading at the end of the next period of swing to the *right*, neglecting the reading at the end of period of swing to the *left*) is the angular measurement of the loss due to retardation by the viscosity of the liquid. These readings should be checked by turning the wire in the opposite direction, and taking a new set of readings.¹ The instrument is usually standardized to express the viscosity

¹ See Gill's "Handbook of Oil Analysis" for a more complete description of this instrument and manner of taking measurements.

in terms of that of cane sugar, a curve being plotted to show the concentration of sugar solutions, giving the viscosities expressed by the angular retardations. With the Doolittle viscosimeter, readings can be taken at any convenient temperature, as there is a water or oil jacket by which the test solution can be heated.

Moisture. — Starch under normal atmospheric conditions contains 12–18 per cent of moisture, according to its origin. This can be driven out by drying at 105° C., but the dried product is extremely hygroscopic and rapidly takes up moisture to the normal amount; for instance, maize starch absorbs about 12 per cent, potato 18 per cent, which cannot be entirely removed at ordinary temperature, even by shaking with alcohol. In fact a rapid method of moisture determination has been developed for potato starch which depends on the removal of part of the water by alcohol. This will remove the water in excess of a constant percentage (11.4). If the starch is dry, it will take up water. The amount absorbed by or taken from the alcohol is determined by taking its density. A table has been prepared by Scheibler which gives the per cent of moisture in the starch corresponding to the density of the alcohol, when 100 cubic centimeters of alcohol and 41.6 grams of starch are shaken together.

Saare's method,¹ which is very convenient, and precise enough for technical purposes (giving results for potato starch correct to .5 per cent), is as follows: 100 grams of the starch are washed into a 250-cubic-centimeter tared flask and made up to the mark with water at 17.5°.

¹ *Chem. Zeit.*, 52, 934.

From the weight of the contents of the flask, the moisture contained in the original starch sample is determined by the following table :

WEIGHT FOUND	WATER PER CENT	WEIGHT FOUND	WATER PER CENT
289.40	0	277.20	31
289.00	1	276.80	32
288.60	2	276.40	33
288.20	3	276.00	34
287.80	4	275.60	35
287.40	5	275.20	36
287.05	6	274.80	37
286.65	7	274.40	38
286.25	8	274.05	39
285.85	9	273.65	40
285.45	10	273.25	41
285.05	11	272.85	42
284.65	12	272.45	43
284.25	13	272.05	44
283.90	14	271.70	45
283.50	15	271.30	46
283.10	16	270.90	47
282.70	17	270.50	48
282.30	18	270.10	49
281.90	19	269.70	50
281.50	20	269.30	51
281.10	21	268.90	52
280.75	22	268.50	53
280.35	23	268.10	54
279.95	24	267.75	55
279.55	25	267.35	56
279.15	26	266.95	57
278.75	27	266.55	58
278.35	28	266.15	59
278.00	29	265.75	60
277.60	30		

Commercial starches often contain an excess of moisture. Whiteness and freedom from offensive odor or taste are necessary qualifications of good starch.

Size Compounds. — Starch is used in immense quantities in the weaving of cotton cloth as the chief ingredient of *size*, which is applied to the warp to protect the threads from chafing during the weaving. Other material is added to the starch to make the size flexible, such as grease, or calcium chloride, which latter, by its hygroscopic action, prevents the size becoming brittle and brings about the same result. Copper sulphate or zinc chloride (the latter also having hydrolytic influence) is added in small quantity to some sizes as an antiseptic to avoid molding or mildewing.

There are numerous formulae for making these sizes, which are usually prepared by the mill people themselves, who mix the size ingredients with the starch paste; which latter has usually been put through some primitive process to make it thin-boiling. The material to give the characteristic properties to the size is usually in the form of "size compound," being a mixture of the fatty or chemical ingredients in a concentrated form in starch paste. As the starchy material is unimportant in the valuation of these size compounds, determinations should be made of the fatty or chemical ingredients.

Dextrin and British Gum. — The term "dextrin," like "glucose," is a much overworked one, as it has many significations. As already referred to, the numerous intermediate products of starch hydrolysis which can be precipitated as definite compounds by alcoholic fractionation are known as dextrins; but these, in their chemical and

Optical behavior, can always be considered as molecular aggregates of a primary "dextrin," whose characteristics are well defined and persist in all such compounds, and the hexose sugars, maltose and dextrose (or, in the case of diastase-converted products, maltose alone), as has been explained. "Dextrin," as used in commerce, refers to a manufactured product of variable composition, made by heating the starch to about 170° C. A certain degree of hydrolysis is effected to a limited extent by the moisture and acids in the starch, and is also in many cases produced by moistening the mass with acid, sometimes hydrochloric, but usually nitric. The darker products, which have been subjected to a more prolonged heating, often to temperatures as high as 270°, without acid, and which give thicker mucilages with water, are known as "British gums," although there is no hard and fast distinction between these products and the "dextrins." These "torrefaction dextrins," as they have been called to distinguish them, are made by roasting in revolving cylinders, either directly heated by a furnace or by an oil bath. In some processes the conversion is carried on in metal trays, which are placed on racks in a kiln. Color and "body" of the mucilages which these products make with hot water are the principal criterions by which they are judged. A good dextrin or British gum should make a practically clear solution with hot water, showing none of the pastiness or colloidal appearance of the unconverted starch. These products are used for a variety of purposes, especially in the textile industries, as well as for mucilage, gum for postage stamps, labels, etc., and in fact for all purposes where a water-soluble gum is needed. There are no fixed

rules for their manufacture, the amount of heating, acid, and other conditions depending on the peculiar requirements of each consumer. Often different dextrans are blended to obtain the requisite quality.

Chemically, they show a small but varying reducing power, which is much less than corresponds to the optical rotation as expressed by the "law of relation" of an acid-hydrolyzed starch product. This would be expected, as not only are products formed by the action of the heat under conditions where all traces of water are absent, except what may be formed by the decomposition of the molecule, but the higher converted and more sensitive products formed in the preliminary hydrolytic action, which always takes place, are to considerable extent destroyed and converted into caramel bodies.

A determination of the specific rotation of a torrefaction dextrin, however, in connection with the cupric-reducing power, often throws valuable light on the conditions of its manufacture. Viscosity tests are most useful in the valuation of a dextrin, speaking generally, but the peculiar use for which the dextrin is designed often demands special requirements. Starches of different kinds also give different qualities of dextrin. Most of these dextrans and British gums are in the form of powders, which, if freshly made, will show under the microscope the form of the original starch grains from which the product has been obtained. Some forms, as "gommelin," are in the state of glassy grains much resembling gum arabic, and are fairly pure hydrolyzed products. Starch "pastes" are made by a gentle hydrolysis, usually with acetic acid, and then thickened with borax, which makes a very stiff mass.

SOME PAPERS ON STARCH AND ITS DERIVATIVES,
BEARING ON SUBJECT-MATTER OF PREVIOUS
CHAPTER

- Musculus and Gruber. — Bull. Soc. chim. (2), 30, 54.
Roudonnesu. — Compt. rend., 81, 972; Bull. Soc. chim. (2), 28, 452.
O'Sullivan. — J. Chem. Soc. (London), 25, 579; 29, 479; 30, 125.
Wiley. — Proc. A. A. A. S., 30, 65.
Brown and Heron. — Ann. Chem., 199, 242; 231, 125; J. Chem. Soc. (London), 35, 596.
Saloman. — J. pr. Chem. (2), 28, 82.
Schulze. — *Ibid.* (2), 28, 311.
Brown and Morris. — J. Chem. Soc. (London), 47, 527; 53, 510; 55, 449; 63, 604.
Brown, Morris, and Millar. — *Ibid.*, 67, 830; 71, 72; 75, 286; 75, 308.
Brown and Glendinning. — *Ibid.*, 81, 388.
Schöbler and Mittelmeier. — Ber. deut. chem. Ges., 23, 3060.
Lütner and Düll. — *Ibid.*, 26, 2553.
Ling and Baker. — J. Chem. Soc. (London), 67, 702.
Rolfe and Defren. — J. Am. Chem. Soc., 18, 869; (Revised: Tech. Quart., 10, 133).
Rolfe and Faxon. — *Ibid.*, 19, 698.
Rolfe and Defren. — J. Fed. Inst. of Brew., 5, 59; Tech. Quart., 12, 191.
Rolfe and Geromanos. — J. Am. Chem. Soc., 25, 1003.
Rolfe and Haddock. — *Ibid.*, 25, 1015.
Krieger. — Zeit. Spiritusind., 1894.
Archbold. — J. Soc. Chem. Ind., 21, 4.

MISCELLANEOUS SACCHARINE PRODUCTS

Milk Sugar. — Milk sugar (lactose) is the only other biose sugar which is produced in the free state in commercial quantities. It is manufactured almost exclusively from whey, usually obtained as the by-product of cheese factories or other curd industries. Whey contains about 5 per cent of lactose.

Lactose crystallizes in large rhombic crystals as the monohydrate ($C_{12}H_{22}O_{11} \cdot H_2O$). These have little sweetness; in fact, pure lactose is practically tasteless. It is much less soluble than cane sugar or maltose, a solution saturated at ordinary temperatures containing no more than about 16 per cent of it. Its specific rotation¹ is 52.5 at 20° , almost identical with that of dextrose. This rotation value is not affected by concentration, but is changed considerably by temperature variations. Lactose has a cupric-reducing power of .73. It is readily inverted by hydrolytes into dextrose and galactose, the rotation of the invert solution being increased to 67° , the specific rotation of galactose being 80° . Concentrated solutions of lactose after prolonged heating for several days become distinctly sweeter in taste from the inverted products formed. Pure milk sugar can be made by precipitation from its aqueous solutions by means of alcohol.

¹ After previously heating the freshly dissolved sugar to boiling.

The manufacture of milk sugar is commonly very crude, consisting in evaporating the whey in open pans and at the same time carrying on a clarification with alum. The rough, dark, crystalline product, containing much mineral matter, is redissolved, subjected to further clarification, and after decolorizing with bone black is evaporated to a concentrated solution in a vacuum pan, and allowed to crystallize gradually.

Three grades of milk sugar are found in commerce: "cobs," cylindrical masses formed on wooden rods immersed in the concentrated sugar liquors, which is the purest kind; "plates," crystal sheets attached to the sides of the tanks; and pulverized sugar, which is the common form in which it reaches the consumer. This latter is usually made from the loose deposit of crystals in the tank bottoms by grinding, or the better quality from the "cobs" or "plates." This pulverized sugar is dried in a kind of granulator before it is packed.

The yield of milk sugar is only about 50 per cent, or, at most, 60 per cent, of that contained in the whey, a considerable loss of the sugar being due to the melassagenic salts in the whey, which amount to nearly 15 per cent of the sugar content, and in part to the crude methods of preliminary extraction.

The ordinary refined milk sugar of commerce contains usually over 1 per cent of mineral matter, but owing to the fact that in drying it is partially dehydrated, samples often polarize over 100 per cent if the sample is tested on the saccharimeter, using the appropriate normal weight.

The normal weight of lactose (*L*) for any saccharimeter obviously bears a ratio to the *sucrose* normal weight,

inversely proportional to the ratio of the specific rotations of lactose and sucrose respectively. That is,

$$L : N = 66.5 : 52.72$$

(52.72, according to Landolt, being the specific rotation of lactose at 17.5° C.). This gives 32.856 grams as the normal weight for the standard half-shade saccharimeter using Mohr cubic centimeter flasks, when the *crystallized lactose* (monohydrate) is weighed, the solution being previously heated.

In the determination of lactose in *milk*, owing to the bulk of the precipitate from the large amount of albuminoid matter present, volume correction must be made by Scheibler's method of "double dilution" already described, or the solution is made up to 102.6 cubic centimeters if the normal weight, 26.048, is used.

Wiley recommends the use of an acid *mercuric nitrate* solution for clarifying solutions, — made by dissolving mercury in double its weight of nitric acid and diluting with an equal volume of water. Usually the milk is measured out by a pipette, an equivalent of two or three times the normal weight being taken.¹ About 3 cubic centimeters of clarifying agent is used for the normal weight, the readings being made as nearly at 20° as possible, as the specific rotation of lactose varies appreciably by change of temperature.

Factory experiments have shown that the quality and yield of milk sugar can be improved by application of modern sugarhouse processes.

Determination of Lactose in Mixtures containing Maltose. — In many quasi-medicinal food preparations, maltose and

¹ Wiley, *J. Am. Chem. Soc.* 18, 428.

lactose are present. Boyden¹ has separated lactose from maltose by recourse to the selective action of a yeast, *Saccharomyce anomolus*, which totally removed the maltose, leaving the lactose unchanged. The lactose was then determined by the Fehling method.

Honey.— Pure honey is, in the main, invert sugar, usually containing also a small quantity of sucrose, waxy matter, and plant extractives. There are also traces of formic acid in honey. The average constitution of sixty samples of honey, according to Sieben, are :

Dextrose,	34.71 per cent
Levulose,	39.24
Sucrose,	1.08
Organic non-sugars,	5.02
Water,	19.98

Honey varies much in composition, according to the food of the bees, as the insects will store up in the comb sugar or glucose sirups in practically unchanged condition. Such honey is usually considered as adulterated, just as when such sirups are added directly to the product. The chemical determinations of honey are solely directed to ascertaining its genuineness as a product elaborated by the bees from the blossoms. The amount of sucrose in a honey rarely exceeds 2 per cent, although there are cases of undoubtedly genuine honey containing more than 5 per cent. Hence, the determination of sucrose, by the Clerget method, is a valuable criterion, honey containing 10 per cent or more of sucrose being unquestionably adulterated. Lead acetate should be used in very small amount, if at

¹ *Ibid.*, 24, 993.

all, in clarification. Commercial glucose can be detected usually by the same method. Advantage has been taken of the temperature effect on the specific rotation of invert sugar to detect adulteration by commercial glucose.

As already stated, the specific rotation of invert sugar decreases by increase of temperature. This is caused by the temperature effect on the *levulose* alone, its specific rotation decreasing about $.638^\circ$ for every degree increase in temperature. Authorities differ by some per cent as to the exact value of the specific rotatory power of levulose, which is approximately -93° at 20° , this value being correct enough for the purpose. At about 88° an invert sugar solution becomes *optically inactive*, owing to the specific rotation of the levulose having decreased to -53° , and hence being just neutralized by the dextrorotatory effect of the equal equivalent of dextrose whose specific rotation is 53° .

Chandler and Ricketts have utilized this property of invert sugar to detect adulteration of honey and cane-sugar sirups by commercial glucose. The sample of invert sugar is heated in a jacketed tube to 87° – 88° by means of a current of hot water (or, as originally, by a heater in a saccharimeter specially designed by the authors).¹ If only invert cane-sugar products are present,

¹ The invert-sugar solution must be neutralized before heating to 87° to avoid any hydrolysis of the glucose. Leach advises to make a separate solution for this test, — 26.048 grams of the sample in 70 cubic centimeters of water to which 7 cubic centimeters of acid is added. The solution is inverted by the usual Clerget process, almost neutralized with sodium carbonate or hydrate, and made up to 100 cubic centimeters. If the ordinary commercial saccharimeter is used, the hot tube must be in the instrument for as short a time as possible to avoid serious errors from the heating of the saccharimeter.

Leach and Lythgoe find that the specific rotation of commercial glucose

the reading will be zero. If the reading shows the presence of commercial glucose, the amount can be approximated closely by taking the specific rotation as 130° and calculating from the usual equations of optical rotation.

Wiley has devised a method for determining *levulose* on similar principles. He uses a saccharimeter specially designed for reading solutions under different temperature conditions, and determines the amount of levulose in 100 cubic centimeters by the standard saccharimeter readings, the solution being made up so that there is approximately the half normal weight of levulose in 100 cubic centimeters of solution. Two saccharimetric readings are taken at temperatures about 50° apart. The levulose present is then given by the following equation:

$$\text{Per cent levulose} = \frac{R - R'}{.0357(t - t')w'}$$

where $R - R'$ is the difference in the reading, and $t - t'$ the difference in temperature, w' being the weight of sample dissolved, and .0357 the difference in reading caused by one degree of temperature on 1 gram of levulose in 100 cubic centimeters of solution.

Maple Sugar. — The carbohydrate of maple-sugar products is sucrose, and, consequently, the methods of analysis of maple-sugar products are identical with those of cane sugar.

at 87° is diminished about 7% of its value at 20° ($\frac{1}{175}$). Leach takes the saccharimeter reading of the (sucrose) normal solution of commercial glucose at 20° C. as 175. This corresponds to a 42° B \acute{e} . commercial glucose [of a specific rotation of about 138°], which Leach has found to be representative of "mixing" glucose. At 87° , the saccharimetric reading was found to be 163.

The fact should not be lost sight of, however, that what gives maple sugar its intrinsic value are the pleasantly flavored plant extractives.

If maple sugar is refined, it becomes nothing more than ordinary granulated sugar, and no more valuable. Stimulated by the government bounties of previous years, which were based on the sugar content, the maple-sugar producers have worked to obtain light-colored sugars with high sucrose content, but which are really inferior to the cruder products on the flavor of which the true value of the sugar depends. This custom of valuing maple sugar solely on its sucrose content has led unscrupulous manufacturers to adulterate the product with cane sugar. It would seem better to base the valuation of maple sugar on a ratio of plant extractives characteristic of the maple to the sucrose content, in addition to the sucrose content alone.¹

Maple sirup, so called, is often manufactured from commercial glucose, cane sirups, and an extract made from hickory bark or corncocks.

Confectionery.—The kinds of confectionery are so various that it will be impossible in the space at hand to describe more than the general characteristics of some common products. In general, candy is an “amorphous” substance, that is, it does not tend to take definite crystalline form, but can be molded to any shape desired. Cane sugar tends to crystallize under almost every condition in

¹ See Hortvet (*J. Am. Chem. Soc.*, 26, 1523), who bases his tests for adulterants on the volume of the precipitated organic matter and the malic acid content. Hill and Mosher have suggested a somewhat similar method. Jones determines the characteristics of the ash. Manganese is said to be a characteristic of maple-sugar ash. This characteristic is probably dependent on local soil conditions, however.

concentrated solution, unless strongly melassagenic bodies are present, but by melting sucrose crystals at 160°, and allowing them to solidify, an amorphous form, "barley sugar," is produced, which, however, gradually becomes crystalline. If, however, a sugar solution is partially inverted, the highly concentrated residue will remain amorphous. Hard candies were originally made by boiling sugar with some inverting agent, commonly cream of tartar or tartaric acid.

Other materials, as gums and clay, have been used in soft candies to "cut the grain" or prevent crystallization. "Fondants," used so much in chocolate creams and bonbons, are made by slightly inverting a concentrated solution of granulated sugar with cream of tartar, and then, when the mass is of the right concentration, as shown by its temperature (about 255° F.), pouring it upon a cold slab, and beating up the mass till it cools. In this way a paste of fine floury crystals is formed, which remains for a long time in this condition if properly made, owing to the crystals becoming coated with invert sugar sirup, which prevents further growth.

In modern candy making, commercial glucose has been found to be an ideal material for "cutting the grain," since the 20 per cent or more of dextrin contained in it is strongly melassagenic, and prevents the crystallization of several times its weight of sugar. Glucose, moreover, is a healthful sweet, which can be obtained cheaply in great purity. Hence it is almost a universal constituent of manufactured candies.

A large class of candies of a soft rubbery nature, like "jujube" and other pastes, cheap gumdrops, and the like,

are made by boiling commercial glucose, diluted to about 35° Bé., for about three hours with 20-30 per cent of its weight of starch with a little tartaric acid, or, preferably, using thin-boiling starch. This class of confectionery is known as "AB goods." "Marsh mallows" are made from gelatin beaten up with glucose and starch.

Aside from the determination of coloring matters, flavorings, and other obvious non-sugars which may cover nearly every process of food analysis, the principles of sugar analysis given in the previous chapters can be applied to determining the composition of candies in general. The Clerget method will give a close approximation to the unaltered cane sugar, the principal error being a small one caused by the hydrolyzing action of the inverting acid on the glucose and other starch products. By determination of the specific rotation of the separated carbohydrate matter, an equation can be formed in which the effect of the sucrose is known and the glucose and invert sugar expressed as unknown quantities. For instance, let S be the per cent of sucrose determined by double polarization, and expressed as a percentage of the total carbohydrate, x being the per cent of glucose and y being the per cent of invert sugar.

Then, $x + y - S =$ per cent of unknown carbohydrate and

$$135x - 93y + 66.5S = \alpha$$

(135° being the average specific rotatory power of the carbohydrate of commercial glucose).

From these equations, the proportion of sucrose (S) being known, the invert sugar and commercial glucose carbohydrate can be determined with sufficient accuracy

for most commercial requirements. If starch is present in a conversion state much less advanced than glucose, it may be necessary to determine the invert sugar directly, and after obtaining the total weight of *carbohydrate*, determine the per cent of starch product by difference. The specific rotation of the starch product obtained by calculation by such methods will be indicative of the amount that the starch has been changed in the making of the candy, and therefore instructive of the process of manufacture.

No definite rules of procedure can be followed in the investigation of candies, as they differ so widely in composition and properties. In any attempt to get at the component carbohydrates, it is obviously necessary to eliminate other material by the usual processes of proximate food analysis. Much organic material of the nature of albumen can be removed by basic lead acetate, but owing to its influence on carbohydrates other than sugar, especially starch products and invert sugar, it is better replaced in most cases by aluminum hydrate mixture. If the carbohydrate is determined by the density, after other organic matter has been removed, ash corrections must be made on the solutions.

It is clear, as in most proximate analyses of complex commercial products, that such investigations of the composition of a candy do not admit of high accuracy, but they do in many cases throw sufficient light on its make-up to be of much value, in fact, to meet all purposes of such work.

Effective application of the many methods of sugar analysis will usually enable the well-informed chemist to

get the desired information in most cases, however complicated the confection.

Jellies and Preserves.—Leach¹ uses the following method for approximately determining the sugars in jellies, preserves, and similar preparations:

When commercial glucose is known to be *absent*, and the sugars consist of sucrose and the invert sugar resulting from the former by the cooking processes of manufacture, a double polarization is made by Clerget's method, the sucrose being calculated by the usual formula: $S = \frac{a - b}{144 - .5 t}$ (see footnote, p. 108).

Inasmuch as the actual numerical value of b , the reading of the (saccharimetric) normal solution after inversion by the Clerget method, is due to the sum of the invert sugar originally present in the sample and that made by the Clerget process, the ratio of the reading b to the reading of a normal solution of pure sugar completely inverted by this process will express the per cent of sucrose (S') in the sample, previous to any inversion in the process of manufacture. (This per cent, of course, is that of the finished product, not of the total weight of the original ingredients which have been changed in manufacture.)

Hence, $S' = \frac{b}{-44 + .5 t}$, since $-44 + .5 t$ gives the reading of a (saccharimetric) normal solution completely inverted by hydrochloric acid. The per cent of invert sugar (I) actually existing in the manufactured product as such can be determined, according to Leach, by the following equation: $I = \frac{105.3(a - S)}{-44 + .5 t}$. (The factor, 105.3, which is the

¹ Leach, "Food Inspection and Analysis." The form of Leach's equations are changed here.

equivalent of invert sugar formed from 100 parts of sucrose, must be used because the value $1 - 44 + .5 t$ corresponds to the invert sugar derived from 26.048 grams of *sucrose*, and not to 26.048 grams of invert sugar already formed.)

When commercial glucose is *present*, Leach determines the amount of this ingredient by polarizing the normal weight of sample at 87° as described on page 226 (see also footnote, p. 226).

Assuming that the saccharimetric reading of a commercial glucose solution, 26.048 grams in 100 cubic centimeters at 87° C., is 163, since the invert sugar at this temperature is optically inactive, the per cent of glucose (G) can be found by the equation, $G = \frac{g}{163}$, where g is the reading at 87° . From g the reading g' of the corresponding amount of glucose at the laboratory temperature (20°) can be calculated by Leach's factor, $\frac{175}{163}$, and the invert sugar in the sample by the equation,² $I = 105.3 \left(\frac{g' + S(-44 + .5 t) - a}{44 - .5 t} \right)$.

It is obvious that errors may be introduced by the heating of the saccharimeter in taking readings at 87° if special care be not taken, or a specially constructed instrument be used.

A definite saccharimetric value is assumed for glucose which is, as has been shown, a product variable in its composition as well as in water content. The glucose may

¹ This value is not strictly correct, as it applies to the rotation of an inverted sucrose solution in the presence of hydrochloric acid which increases the saccharimetric reading. The reading a is taken before adding the inverting acid.

² A simpler equation would seem to be: $I = 105.3 \left(\frac{a - S - g'}{-42 + .5 t} \right)$.
See footnotes on pp. 107 and 108.

change during the manufacture of many of these products, the change in the main being a partial dehydration. If the dehydration be sufficient to reduce the water content of the product below that in the original glucose (about 20 per cent), it is clear that the glucose rotation will be changed proportionately to the (practically anhydrous) sucrose and that the assumed saccharimetric value of 175° will not apply for such goods.

Hence, when it is possible to remove the organic matter, not carbohydrate, by suitable clarification methods, a procedure based on the density method previously described would appear to be more accurate, as errors due to dissolved mineral matter can be eliminated by the ash correction already described. Values calculated from the specific rotation of the anhydrous substance are not affected by variation which may have taken place in the water content of the product.

The per cent of total solids in the sample can be obtained with sufficient exactness for calculating the proportions of carbohydrates in terms of the original weight of sample, the glucose being assumed to have been originally an 80 per cent solution. If the weight of total carbohydrates can be calculated, reading at 87° is unnecessary for determining the glucose (see p. 230). Of course, as in Leach's procedure, the specific rotation for the anhydrous glucose must be assumed.

Hydrolyzed Products of Cellulose.—Ever since 1819, when Braconnot exhibited sugar made from linen rags at a meeting of the French Academy, cellulose has been considered as a possible material for sugar production, but, until recently, attempts to manufacture sugar or gums

from wood waste economically have given yields so low as to be of no practical value. It is, nevertheless, easy to repeat Braconnot's work, which consisted in treating the linen with about twice its weight of sulphuric acid till the whole mass became a paste, and, after diluting with water to about a 2 per cent solution, heating for ten hours. The neutralized solution on evaporation yielded dextrose. Any attempt at more economical production, by increasing the proportion of cellulose and decreasing acid, results in an insignificant yield. The practical difficulty seems to lie in the formation of insoluble intermediate products, analogues of dextrin, which are only broken up by large excess of acid. The small amount of soluble product formed is optically active, its specific rotation being usually about 40° , the cupric reduction about .90 as found in experiments in hydrolyzing cotton with sulphuric acid.¹ This corresponds to a mixture of *xylose* (a pentose sugar of specific rotation of 19.2° , and cupric-reducing power of 1.10) with *dextrose*, but the data at hand are not complete enough to be conclusive. Cross and Bevan have experimented considerably on the hydrolysis of cereal straws, and also find pentose sugars.

Comparatively recently, Claassen has patented processes for conversion of cellulose into fermentable sugar by which a large yield is claimed. The unique and vital feature of the process is the conduct of the hydrolysis under mechanical pressure, subjecting a mass of sawdust moistened with sulphuric acid to the action of a press. This is said to give soluble saccharine product in large amount, which can be utilized in the economic production of alcohol.

¹ *Tech. Quart.*, 12, 51.

APPLICATION OF THE POLARISCOPE IN SCIENTIFIC RESEARCH

Laws of Optical Isomerism.—In the opening chapter, reference was made to the important theory relating optical activity to chemical structure which was developed by two independent workers, Van't Hoff and Le Bel. Only an outline of the more important general laws developed from this theory, that may be necessary for a comprehension of the chapters following, will be given here.

Theoretically, any substance showing optical activity can exist in at least three isomeric forms: one which is dextrorotatory; another of equal rotation value but left rotating; and the third, a chemical compound of equal equivalents of the dextro- and levorotatory isomers; this last being optically inactive and termed the "racemic" form. By the Van't Hoff-Le Bel theory, the laws relating the molecular structure of these isomeric forms to their optical activity can be expressed by the following graphical symbolism, which is derived from that commonly used to interpret the chemistry of carbon compounds.

Most optically active substances can be symbolized by one of three schemes of configuration. The first can be generalized in the form, $R-C a b-R'$, R and R' representing unlike terminal radicals, and C any number (n) of carbon atoms, each carrying the unlike radicals, a and b ,

and connected to these two terminal radicals in a continuous chain. The number of different symbolic images which can be made by varying the arrangement of the univalent radicals a and b attached to the intermediate carbon atoms (C) determines the number of isomers theoretically possible.

Those figures symbolize *optically active* isomers which show an arrangement of a and b *not symmetrical* ("asymmetrical") to the carbon chain; that is, if the figures are divided along the median line of the carbon chain, or bisected horizontally, the two halves are not identical. Such figures can be grouped in pairs which represent arrangements of a and b making *mirror images* of each other¹ ("enantiomorphic"). The images so related typify isomers which have many physical and chemical properties in common, but which rotate the polarized rays equally in opposite directions. Such isomers are said to be "antipodal" to each other.

In this specific scheme of configuration, $R-C a b-R'$, figures which show symmetrical distributions of a and b on each side of the median carbon line also represent optically active substances, there being no representation of optically inactive bodies; for owing to the unlike terminal radicals, the figure halved horizontally would still be asymmetrical. Actually, all bodies not racemic whose properties can be interpreted by this graphical representation have been found to be optically active.

The following symbols of the possible isomers of an optically active body containing five radicals, three of which

¹ The assumption is made, of course, that a and b are each represented in the figure by some symmetrical character, as for instance a by a dot and b by a circle.

are "asymmetric carbon atoms," will illustrate the manner of predicting the optically active isomers:

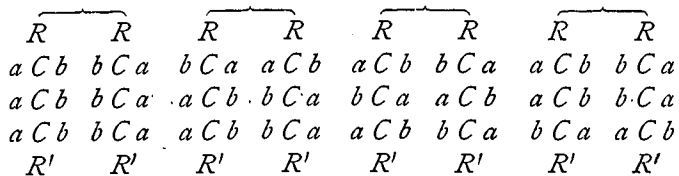

Those which are paired as representing "antipodes" which can form racemic compounds are joined by brackets. Consequently, four racemic isomers are possible in compounds represented by this scheme which contain five carbon atoms.

By the mathematics of permutation and combinations the possible number of optically active isomers (N) which can exist according to such a scheme can be computed by $N=2^n$, where n represents the number of "asymmetric carbon atoms" expressed by C in the formula, $R-Cab-R'$.

All the hexose (glucose) sugars as well as the pentose and other carbohydrates can be represented in this scheme. For instance, from an elaborate investigation of dextrose ($[\alpha]_D = 52.7$), Fischer has symbolized this sugar:

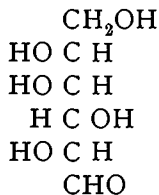

According to theory, a levorotating isomer should exist whose structure can be symbolized by a figure the mirror image of this. Fischer actually isolated a left-rotating

sugar which has many of the properties of dextrose and a specific rotation of -51.4 . Likewise, many other antipodes of this group have been isolated or made synthetically, so that of the sixteen isomers of the simple hexose sugars theoretically possible according to the equation $N = 2^n$, a dozen or more are known.

The second scheme of configuration for graphically representing the chemical structure of optically active compounds is expressed as $R-C a b-R$, where the terminal radicals are *alike* and the carbons expressed by C , to which the two radicals determining optical activity are attached, are *even* in number. In this scheme, $N = 2^{n-1} + 2^{\frac{n}{2}-1}$, of which 2^{n-1} represent optically active isomers, since $2^{\frac{n}{2}-1}$ figures, having symmetrically distributed a and b groups relative to the two like terminal radicals (as shown by dividing such figures in halves horizontally) are optically inactive.

Tartaric acid is typical of this group. The symbolic representation of this acid shows two "asymmetric carbon" groups. Hence there are two possible optically active isomers and one inactive. These can be represented by the following symbols:

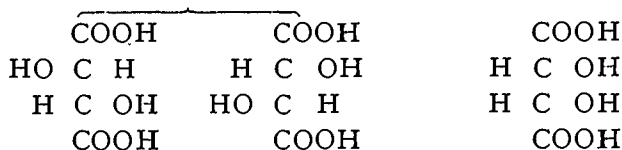

The first two are antipodes, in combination forming the optically inactive racemic acid. The third (mesotartaric acid) is the inactive isomer, as predicted by the equation.

The third scheme of configuration representing the isomerism of the remaining compounds which can be symbolized by a representation of a chain of carbon nuclei, is identical with the second except that the number of carbon atoms determining the asymmetric groupings (n) is *odd*. In this scheme the figure can be halved horizontally on each side of a middle carbon group. When the grouping of the radicals expressed by a and b is symmetrical relative to this middle carbon, the isomer is optically inactive. The total number of optically active isomers (N) is, in this case, $N = 2^{n-1}$, the number of optically active being expressed:

$$A = 2^{n-1} - 2^{\frac{n-1}{2}}.$$

The inactive isomers obviously are expressed by $I = 2^{\frac{n-1}{2}}$. Trioxylglutaric acid is an example of this class.

While the examples cited have to do with arrangements of hydrogen and hydroxyl radicals, similar arrangements of other radicals also represent optical activity, the essential being the "asymmetric carbon" nuclei which permit of configurations which are mirror images of each other. So, too, optically active bodies exist whose chemical structure can be explained by the ring representation, characteristic of the so-called aromatic compounds. These can be demonstrated satisfactorily only by a solid figure, three dimensions being necessary. The asymmetric carbons in such figures are best represented as tetrahedra. It will suffice to state here that when the substance is represented by a ring structure and only one asymmetric carbon is present, there are three isomers, two of which are antipodes, and the third is the corresponding racemic compound. Many constituents of the essential oils, as

pinene, limonene, and camphene, are represented by this configuration.

If two asymmetric carbons are in the ring configuration, there are two possible antipodes and their corresponding racemic forms. There are also a few instances in which optical activity can be explained by figures containing asymmetric nitrogen or sulphur.

In *natural* products, as a rule, only one or the other antipode of an optically active substance is found, rarely the racemic combination. In fact, racemic forms of many optically active substances, as starch, are unknown. On the contrary, *all bodies ordinarily optically active in the natural state are inactive when made by synthesis from inactive substances*. This is due to the formation of equal equivalents of the antipodes and consequent racemic combinations. In order to separate the antipodes of such synthetic compounds, many ingenious chemical and physical methods are resorted to.

Antipodal substances show identical physical and chemical characteristics when isolated or in chemical combination with optically inactive substances, if certain crystalline and electric peculiarities (also, in some cases, physiological effects) are excepted.

If, however, antipodal substances are combined with an optically active body, there is often a noticeable change in the properties of the compounds formed by each antipode. In this manner, many racemic compounds made by synthesis have been resolved into these antipodes. The alkaloids have proved valuable in these separations, since, owing to the difference in solubility of many antipodal salts formed by combination with these bases, many isomers

can be separated by precipitation. By combinations with the alkaloids, strychnine, morphine, brucine, and cinchonine, Fischer was enabled to obtain optically active dextrose and its levo-isomer from the optically inactive racemic body synthesized from acrose.¹

Antipodal isomers have also been separated by the action of some of the lower vegetable organisms as certain molds, yeasts, and bacteria, also many of the enzymes which show selective action in destroying one antipode. Fischer showed that the yeasts, as a rule, attacked the naturally occurring dextrorotatory forms of dextrose, maltose, and mannose, but did not ferment the levo-isomers separated by synthetic processes. On the contrary, levulose was attacked, but not its dextro-isomer.

Determinations of Specific Rotatory Power. — In the explanation of specific rotatory power, previously given, only an allusion was made to the disturbing effects of solvents and temperature which occur in the case of many compounds, as these influences on the sugars heretofore discussed are so slight as to be of little importance in most commercial analysis. Invert sugar and the temperature influence on milk sugar are excepted, temperature coefficients of which have been given.

Since the specific rotations of the ray of standard wave length caused by many substances, when calculated from solutions of different concentrations and from those in different solvents, do not give constants, it is customary in practical work to calculate such values from solutions made from the specified solvent containing 10 grams of substance in 100 cubic centimeters (or what is usually

¹ *Ber. d. chem. Ges.*, 23, 370, 799, 2133; 25, 1255.

sufficiently identical for this purpose, a concentration of 10 per cent, readings being taken at 20° to eliminate any temperature disturbance.

To eliminate the influence of the solvent, the so-called "absolute" specific rotation of an optically active substance is often calculated. Biot, in investigations begun in 1838, and extending over twenty years, showed that this could be obtained by plotting curves representing the variations in the apparent specific rotation calculated from different concentrations of solution, each solvent giving an independent curve. If the per cent of solvent in each solution polarized is plotted as an abscissa, and the corresponding value of the apparent specific rotation as an ordinate, a curve is made which is either a straight line or can be considered a hyperbola or parabola. If the line is straight, the absolute specific rotatory power can be expressed by the formula $[\alpha]_D = A + Bq$, where q is the per cent of solvent present, and the constants A and B calculated from the plots, A being the absolute specific rotation, B the rate of its change with the quantity of solvent present. If the line is a curve, the equation $[\alpha]_D = A + Bq + Cq^2$ is sufficiently correct for practical purposes in the majority of cases. If the per cent of active substance is expressed by p , the equations become $[\alpha]_D = A + B(100 - p)$ and $[\alpha]_D = A + B(100 - p) + C(100 - p)^2$.

In the equation $[\alpha]_D = A + Bq + Cq^2$, the constants B and C can be obtained by determining the apparent specific rotations from three solutions of different concentrations:

¹ So, too, p/d can be substituted for p , giving the equation for concentration expressed as $\frac{[\alpha]_D}{d}$. As the density influence of most substances in solution is not a constant, however, such equations are not precise.

$$[\alpha]_{D_1} = A + Bq_1 + Cq_1^2. \quad (1)$$

$$[\alpha]_{D_2} = A + Bq_2 + Cq_2^2. \quad (2)$$

$$[\alpha]_{D_3} = A + Bq_3 + Cq_3^2. \quad (3)$$

If (2) is subtracted from (1) and (3) from (2):

$$[\alpha]_{D_1} - [\alpha]_{D_2} = B(q_1 - q_2) + C(q_1^2 - q_2^2). \quad (4)$$

$$[\alpha]_{D_2} - [\alpha]_{D_3} = B(q_2 - q_3) + C(q_2^2 - q_3^2). \quad (5)$$

From (4)
$$B = \frac{[\alpha]_{D_1} - [\alpha]_{D_2} - C(q_1^2 - q_2^2)}{q_1 - q_2};$$

$$B = \frac{[\alpha]_{D_1} - [\alpha]_{D_2} - C(q_1^2 - q_2^2)}{q_1 - q_2}.$$

From (5)
$$B = \frac{[\alpha]_{D_2} - [\alpha]_{D_3} - C(q_2^2 - q_3^2)}{q_2 - q_3} - C(q_2 + q_3).$$

Hence:
$$C = \frac{[\alpha]_{D_1} - [\alpha]_{D_2}}{(q_1 - q_2)(q_1 - q_3)} - \frac{[\alpha]_{D_2} - [\alpha]_{D_3}}{(q_2 - q_3)(q_1 - q_3)}.$$

Landolt has proved by experiment, in the case of a large number of optically active substances, that the value A , determined mathematically by Biot's formulæ, represents the true or absolute specific rotation.

The example most cited is that of oil of turpentine. If the specific rotation of this substance is determined directly by polarizing the pure oil, free from solvent, the specific rotation, calculated from the formula $\alpha = \frac{a}{ld}$ is 14.15° . If the specific rotation values are obtained from alcoholic solutions of various concentrations, the values increase with the dilution, an 80 per cent solution having a specific rotation of about 14.4° , a 20 per cent about 15.2° . The plotted values obtained at different concentrations form a

straight line, which is represented by the equation $[\alpha]_D = 14.17 - 0.00178 \rho$, D in this case being identical within experimental error with the value actually obtained by polarizing the pure oil, free from solvent.

In cases where it is impossible to polarize the substance free from solvent, as in the case of camphor or tartaric acid, plots made by dissolving the substances in different solvents give curves which, while of different forms, all converge to a common focus, which expresses the common value of D obtained in each equation. In some cases these curves show an increase in apparent value of the specific rotation with dilution, as in the case of oil of turpentine and tartaric acid; in others a decrease, as those of camphor and tartaric acid. Nicotine in dilute water solutions is peculiar in giving a curve which gradually decreases with dilution to a minimum at about 8 per cent, and then increases. Camphor shows the same minimum value with some solvents. Malic acid and its sodium salts show even a reversal of the direction of rotation at certain concentrations.¹

The *temperature* effects on the specific rotations of optically active solutions have not been formulated except in comparatively few instances.

The rotation of a mixture of optically active substances in solution, when these substances do not react upon each other, is the resultant of their individual rotatory effects, as has been proved by many experiments. Acids, alkalis, and many salts influence the rotatory effects of optically

¹ See Landolt's "Optische Drehungsvermögen" for a complete account of the researches on specific rotation. See also, on tartrates, E. B. and F. B. Kenrick, *J. Am. Chem. Soc.*, 26, 1045.

active bodies, but in most cases present knowledge is insufficient to show whether in certain cases chemical action takes place or not. Apparently in some cases polymerization affects optical rotation, although many experiments, as those with itaconic acid,¹ show the opposite.

A large and attractive field of research in physical chemistry is opened and yet but little worked in optical investigations of molecular structure by means of the polariscope. The only line which has been followed up in this direction to any extent has been that pointed out by the researches of Pasteur and Van't Hoff.

Attempts have been made to apply the theory of electrolytic dissociation to optically active solutions containing salts, acids, and bases; and the investigations of Oudemans and later Hädrich² on alkaloids have established the following law: the rotating power of electrolytes in general in dilute solutions, where the dissolved substance is largely dissociated into its ions, is independent of the inactive constituents of the salt. For instance, different quinidine salts diluted to the extent of a "gram equivalent" (the molecular weight in grams) in 20 liters of water or more, show identical rotation values which gradually increase up to a dilution of the gram equivalent in 80 liters, being constant at greater dilutions. The salts of morphine behave in a similar way, as do those of brucine and strychnine, although the specific rotation becomes constant in the case of the two latter alkaloids at lower dilutions.

¹ Walden, *Zeit. phys. Chem.*, 20, 383.

² Hädrich, *Ann. Chem. Liebig*, 207, 257.

Molecular Specific Rotation.— In calculations of the rotatory effect of the molecule in physical chemistry, the "molecular rotation" (symbolized, M) is sometimes used as the optical unit. This is obtained by multiplying absolute specific rotation by the molecular weight of the substance. Usually for convenience 1000 of this unit is taken (symbol, $[M]$).

Many attempts have been made to establish laws which would express the influence of molecular structure on rotation values, but with little success, the Van't Hoff-De Bel theory being still incomplete on these lines, as shown by the work of Guye, Walden, and others. The principal law which does hold good is one of Van't Hoff that if a compound contains several "asymmetric" carbon atoms and consequently several optically active groups, the rotation is the algebraic sum of the group rotations. This has been found to be exactly true by the work of Guye¹ and Walden on the liquid amyl esters, and is of vital importance, as on its establishment depends the correctness of the whole theory of isomeric sugars as developed by Fischer, as well as the methods of investigation of hydrolyzed starch compounds already explained.

Multitrotation ("birotation").— Many sugars when freshly dissolved and polarized give initial temporary rotation values which gradually change and become constant after some hours. This phenomenon was first observed by Dubrunfaut, in 1846, in dextrose solutions. This transition condition of the specific rotation has since been found to exist in many sugars and other compounds as well, as in oxyacids and their lactones, nicotine, and some amine

¹ Guye, *Compt. rend.*, 121, 827.

bodies. The optical values may increase or decrease toward a constant, and some sugars form two optically unstable or "labile" modifications, according to the conditions of their extraction from concentrated solutions. Both these forms revert to the stable condition at a rate dependent on the presence of any catalytic bodies which hasten the change; the laws of the rate of hydrolytic change of Wilhelmy and the principle that the influence of the acids was proportional to their "affinity constants" applying generally. Alkalies, even in very dilute solutions (.1 per cent ammonia, for instance), produce an almost immediate change of rotation to the constant value, and by prolonged action at greater concentrations produce changes in rotations of many of the sugars which can only be explained by the formation of new compounds. Lobry de Bruyn and Van Ekenstein have shown that this is due to the formation of isomeric sugars rather than phenomena of multirotation.

Bringing the optically active solution to a boil gives the constant rotation value, for the optical transition, analogous to hydrolytic change, is enormously accelerated by temperature increase. As already noted, this latter procedure of heating the solution is necessary in analytical operations, as, for instance, when dealing with freshly dissolved milk sugar or dextrose. Cane sugar shows no multirotation. The monohydrate of dextrose, which is the form which commercial "grape sugar" takes, shows multirotation similar to the anhydride.

The following table shows the specific rotations of the labile and stable forms of the more important sugars:

	β	α	γ
Dextrose	52.7°	105.2°	32.5°
Galactose	81.6°	135.0°	52.3°
Lactose	52.5°	80.2°	34.4°
Maltose	138.0°	118.2°	
Levulose	92.5°	104.0°	
Arabinose ¹	104.4°	156.7°	
Xylose ¹	10.2°	94.4°	

α is the labile solution made by dissolving the crystallized sugar in water; β the stable solution; γ a second unstable form, usually produced by heating the residue evaporated from solution, or by precipitation with alcohol.

Mutrotation seems to be a phenomenon resulting from hydration of the substance, accompanied by a rearrangement of the optically active groups, but it has not been completely explained.

Laws of Hydrolytic Change.—The polariscope has been of great service to science as a means of measurement of comparative chemical activity of hydrolyzing substances, particularly acids; and, as the constants so obtained have a very direct and intimate relation to those determined by electrical conductivity and other methods of measurement of chemical affinity, they are usually termed "affinity constants."

Wilhelmy, in 1850, was the first to formulate a mathematical expression of the laws governing the chemical change produced by hydrolysis. Thereby was opened up a field of research which has had enormous influence on the science of chemistry as a whole, and greatly widened

¹ Pentose sugars ($C_5H_{10}O_5$).

our comprehension of the mechanism of chemical action. His formulation is as follows: If B is the original amount of sugar subjected to inversion at a fixed temperature under the influence of an acid of known concentration A , and dx is the amount inverted in a given increment of time dt ; x will represent the sugar inverted at the end of t minutes, and $\frac{dx}{dt} = cA(B - x)$, where c is a constant dependent on the nature of the acid and temperature.

By the mathematical method of integration, this becomes:

$$\text{nat log } \frac{B}{B - x} = Act.$$

B , the amount of cane sugar at the start (or at any chosen moment during the reaction when t is taken as zero), is directly proportional to $R - R'$, where R is the reading of the polariscope given by the sugar solution at this chosen moment, R' the reading of the solution when completely inverted. The value of $B - x$ is proportional to $R'' - R'$, R'' being the polariscope reading taken at the time t . Evidently Ac is a constant as calculated from this equation, since the concentration of the acid remains unchanged throughout the inversion, owing to its action being catalytic.

If a series of the constants are obtained from inverting a sugar solution by *different* acids, under fixed conditions of temperature and concentration, their ratios will represent the *comparative affinities* of the two acids. Usually these are expressed in terms of the affinity value of hydrochloric acid taken as 100.

The method of determining these affinity constants does not require detailed description. Outside of the usual precautions necessary in precise polarimetric observations,

the influence of even minute temperature variation must be guarded against with particular care. The polariscope tube or bath in which the inversion is taking place must be carefully protected from radiation, and be kept at a constant temperature by means of a circulating jacket or other similar device in which the water temperature is kept constant within the limits of measurement of a delicate thermometer, certainly within $.01^{\circ}$ for accurate work. Ingenious thermostats have been specially devised for this accurate control.

Polarimetric readings are made at regular time intervals reckoned in minutes from any chosen period in the course of the inversion taken as an initial point. The reading of the solution when so completely inverted that no further change in the readings occurs must also be known.

As the value of the ordinary, or Briggs, logarithms bears a constant relation $\left(\frac{1}{.4343}\right)$ to those of the "natural" or Napierian logarithms, the former are usually more convenient to use, as the constant values so obtained can be readily converted into the true constants as derived from the exact formula. The calculation is very simple, as the equation given above shows. The logarithm of the difference between the reading of the solution at the time t and the reading of the completely inverted solution is subtracted from the logarithm of the difference between the reading at the initial moment when t is taken as zero and that of the completely inverted solution. The value thus obtained for each reading is divided by the appropriate number of minutes which determine the time of the reading, the quotient giving the required constant.

The influence of temperature on hydrolytic change is very great, the increase up to about 80° causing a very rapid acceleration in the rate of inversion. Above this temperature, the temperature coefficient gradually diminishes, the plot of the values forming a convex parabolic curve. Unfortunately for the practical applications of the laws of hydrolytic change, in spite of the enormous mass of data which have been collected, these temperature coefficients under different conditions of inversion have not been formulated into any law of general application.

The work of Spohr, Urech, and Arrhenius has, however, developed the following equation to express change in the inversion constant of an acid at any temperature t_0 between 1 and 50°:

$$C_1 = C_0 \cdot \epsilon^{\frac{A(T_1 - T_0)}{T_1 T_0}},$$

T_0 being the temperature at which the inversion is made and T_1 that at which the other inversion takes place, both being expressed in absolute temperatures ($t + 273^\circ$). ϵ is the natural logarithmic base, 2.718281. As this equation requires the determination of a new constant, apparently dependent on the special conditions of the inversion, it can be applied only in specific cases where such constants have been determined with more or less accuracy.

Sigmond found the value of A to be 12820 at 69.3° C., or at about the most favorable inverting temperature of sucrose. He also found the equation held to 100° (*Zeit. Phys. Chem.*, 27, 386).

Until these temperature laws on the constants of inversion for the common acids are developed more completely, the results of modern physical chemical research on hydrolytic change will have but a limited practical application

for the sugar chemist, but they promise much in the future. This sketch of the more important laws bearing on the subject is introduced here merely to point out the great value of polarimetric investigations in this line.

Hydrolysis of Starch. — In the hydrolysis of starch products, the law expressing the rate of change is obviously more complicated; for, if we consider the hydrolysis as practically the resolution of the primary dextrin groups into maltose and the simultaneous inversion of the latter into dextrose, evidently the reaction has to deal with two distinct chemical transformations taking place at the same time. The transformation of dextrin into maltose is in accord with the law discussed above, and consequently can be expressed as in sucrose inversion by the equation :

$$\frac{D}{D - \alpha} = Act. \quad (1)$$

A formula can be derived from the exact differential equation, $\frac{dD}{dt} = c_2 M$, which states that the amount of dextrose (D) formed at each moment is proportional to the amount of maltose (M) present by replacing the differential quantities by finite differences which in applications of the formula must be taken small. In the place of M , the average amount of maltose present during the interval of time considered is substituted. That is, if M_1 and M_2 are the amounts of maltose present at these times, and c_2 is the reaction constant, the result of the above substitution is :

$$\left(\frac{1}{t_2 - t_1} \right) \left[\frac{D_2 - D_1}{\frac{M_1 + M_2}{2}} \right] = c_2 \quad (2)$$

By these formulæ two constants were found for each conversion in a series of hydrolyses of corn starch made with different acids under varying conditions of concentration of the hydrolyte and temperature. As the hydrolysis of starch is relatively slow with dilute acids at ordinary laboratory temperatures, the reactions were carried out under steam pressure varying from 1 to 4 atmospheres in

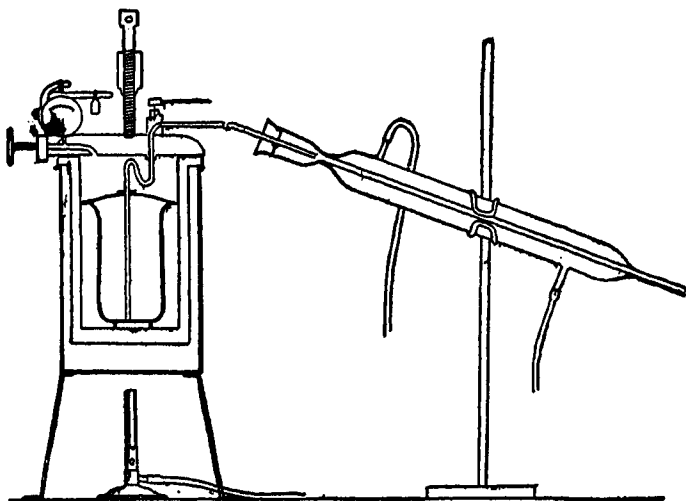

FIG. 38.—DIAGRAM OF AUTOCLAVE FOR ACID HYDROLYSIS OF STARCH ARRANGED FOR REMOVAL OF SAMPLES WITHOUT INTERRUPTION.

an autoclave specially arranged for removal of portions of the solution at any desired stage of the hydrolysis. The amounts of dextrin and maltose per unit of total carbohydrate in solution were calculated from the specific rotatory power of the solutions, by the method described in a previous chapter. The values so obtained were fairly constant, tending to increase slowly as the hydrolysis proceeded.

The comparative affinity constants of the acids used (hydrochloric, acetic, sulphuric, oxalic, and sulphurous) derived from the results of this investigation, gave values in practical agreement with those obtained from sugar inversion.¹

Application of the Quartz-wedge Saccharimeter to General Polarimetric Measurements.—The great convenience in manipulation and the precision of the quartz-wedge saccharimeter make it the most desirable instrument for polarimetric measurements when its use is permissible. The application of the quartz-wedge saccharimeter, however, is strictly limited by the following conditions: (1) the restricted scale which measures rotations between about 35° and -10° , although these measurements can be extended by the use of standard quartz plates of known dextro- and levorotatory values; (2) the necessary condition that the "rotatory dispersion" of the solutions polarized closely approximates to that of quartz; that is, if the ratios of the rotations of the different rays of the spectrum caused by the solution are not practically identical with those given by quartz, there will be no position of the wedges at which the proper thickness of quartz can be interposed to give complete compensation. Consequently, in such cases, the end point given by the solution will not be identical with that at the zero reading, and the precision of the measurement will be seriously impaired thereby. In the standard shadow saccharimeter, this unequal dispersion manifests itself by a party-colored field at the end point instead of an equally tinted one. As the rays at the violet end of the spectrum are the principal disturbing

¹ For speed of hydrolysis of starch by *diastase*. See Brown and Glendinning, *J. Chem. Soc.*, 81, 388.

ones, this party-colored field can be largely prevented by filtering the light through a solution of potassium bichromate, or a section of a crystal of this substance, when the difference in dispersion is not great. In the case of commercial glucose and most starch products, as well as sugars other than sucrose, the bichromate cell is effectual, and is usually part of the equipment of the saccharimeter. If the inequality of dispersion is considerable, as in the case of many essential oils, sodium light must be used.

Light Factor.—The equivalent of one division of the saccharimeter in angular degrees of rotation of the plane of polarization of the standard yellow ray is called the "light factor" of the saccharimeter. Until comparatively recently, the factor .3455 was considered correct¹ in all cases to convert readings in divisions of the Ventzke scale to rotations of standard yellow light in angular degrees. Landolt in 1888 and Rimbach in 1894 published results of comparative readings of various sugars, showing that this factor varied in many cases with the nature of the sugar, being nearer to .345 for dextrose, for instance, than .346; and establishing the fact that the light factor is not a constant, but varies with the nature of the solution polarized, being dependent on the difference between the dispersion of the substance and that of quartz, as it is, obviously, on temperature. There are also other variations in light-factor values which have caused considerable confusion in establishing the exact equivalent of the standard quartz-wedge saccharimeter. These are due to the fact of the existence of saccharimeters with scales based on a dif-

¹ This factor is correct for the rotation equivalent as determined by quartz readings on the Laurent polariscope at 17.5°.

ferent graduation from that of the Ventzke standard, and furthermore to changes in the optical centre of the yellow light used as the standard of measurement in rotatory polariscopes. The factor .3458 is correct at 20° for conversion of the divisions of the standard Ventzke scale into angular degrees of rotation as given on the Laurent saccharimeter, for substances having the same dispersive power as *quartz*.¹ If, however, the light standard of the Lippich ray filter is taken, the light factor becomes .3466, while with the true centimeter saccharimeter scale, the factor is more nearly .3469. In the case of cane sugar, the factor is practically the same as quartz under the same standards of measurement, but with *hydrolyzed starch* products, with the Ventzke saccharimeter, it varies from .3443 for the Laurent standard at 20° to about .3450 with the Lippich ray. If sodium light is used with the saccharimeter, the influence of dispersion will be eliminated, and the factor will be constant at the same temperature for all solutions: Use of sodium light sacrifices much of the convenience of the quartz-wedge saccharimeter, but qualifies the instrument for measurements of all optically active substances.²

¹ Throughout this book, it has been assumed on the authority of Landolt (p. 364) that sodium light passed through the Lippich ray filter has an optical centre practically identical with that of the spectrally purified light (see footnote, p. 11). Recent rotation measurements of quartz plates do not, however, confirm this identity in every case.

² If the modern quartz-wedge saccharimeter is graduated to give the exact sugar values for solutions at all concentrations represented on the scale, as Von Lippmann ("Chem. der Zuckart.," III ed. 1363) asserts and many of the quartz-plate readings made by the author show, obviously the light factor in the middle of the scale will be slightly different from that at the ends. For instance, the light factor of a U. S. standard instrument apparently so graduated is .3467 at the 100 point, but .3469 at the 60.

APPLICATION OF THE POLARISCOPE TO CHEMICAL ANALYSIS OTHER THAN CAR- BOHYDRATE DETERMINATIONS

While there is a wide field for the application of the polariscope in the analysis of many organic compounds, comparatively few systematic methods of analysis have been developed as yet. Perhaps one reason for this neglect of the polariscope in quantitative organic analysis is due to the fact that the specific rotations of most optically active substances are affected to a large extent by the solvents usually necessary in polarizing, as explained in the preceding chapter. In consequence, since in the simple equation expressing the fundamental laws of rotation, $\alpha = \frac{a[\alpha]_D}{v}$, α is not a constant at different concentrations, as it is practically in the case of cane sugar, the formula for calculation of the optically active substance is often very complicated. This drawback is not a serious one, however, as is shown by the steadily increasing number of polarimetric methods which are being applied in organic analysis, and these will become of more general use as the fundamental principles of optical analysis become better known. As will be explained farther on, another reason why little has been done in applying polarimetric methods to the quantitative measurement of the optically active substances themselves is the variation of these constituents in most plant products, such as the essential oils and

drugs, as well as the complication of their mixture. Hence the polariscope has been of service principally in determining the purity of such products as are characterized by approximate rotation constants. These rotation figures in conjunction with the density and refractive index have been particularly valuable in the identification of the essential oils and detection of adulterants. The indications of the instrument in such cases can be looked on as in a sense qualitative rather than quantitative.

In general, the rotatory polariscope is more suitable for determinations of oils and drugs, owing to the great variation in the rotation dispersion of these substances. The quartz-wedge saccharimeter is, however, universally applicable if sodium light is used as the illuminant and the readings are converted into angular rotation equivalents by the appropriate light factor. As many of the liquid products can be put into the polariscope tube without preparation and polarized directly, and as the specific rotations are often very large, it may be advisable to use tubes of shorter lengths than for sugar analysis, even as short as .25 decimeter. In exact quantitative measurements with such tubes, due allowance must be made for the increased error in the use of such short lengths.

Camphor.—Förster¹ has devised a method for determining camphor in celluloid which is as follows: About 10 grams of celluloid are saponified with four times this weight of sodium hydrate (10 per cent). After dilution with water, the camphor is distilled off with steam and collected in about 25 cubic centimeters of benzol by shaking

¹ *Ber. dent. chem. Ges.*, 23, 2981. See also for camphor in oils, Leonard and Smith, *Analyst*, 25, 202.

up the distillate with that liquid. After making up to a definite volume, the benzol solution is polarized at 20° C. The specific rotation is expressed by the following formula, $[\alpha]_{D^{20}} = 39.755 + .1725 \tau c$, from which is derived $\tau c = 2.4683 \frac{\alpha}{l} - .01747 \left(\frac{\alpha}{l}\right)^2$ for the weight of camphor in 100 cubic centimeters. The equation is more complicated than that expressing the concentration of sugar solutions, owing to the marked action of the solvent on the rotation.¹

Chinchona Alkaloids.—The valuable medicinal alkaloids of the chinchona plants are very numerous, over thirty having been isolated. They are all tertiary amines, strongly basic in their nature, and most of them of pronounced optical activity. Isomers and polymers are often found together, so that an exact determination of the constituent alkaloids in the bark of the plant by any polarimetric method is too complicated to be practical. An additional difficulty is the great influence that the ordinary solvents of these alkaloids have on their specific rotations.

It is usually necessary to isolate the alkaloids by chemical separation processes before making a quantitative determination by the polariscope. Many such processes are in use. One will illustrate,—the determination of quinine and chinchonidine in a chinchona bark :

All the alkaloids present are first set free by treating the powdered bark with calcium hydrate, by making a paste with water; then extracting with a mixture of three parts of benzol and one of amyl alcohol, by boiling for half an hour, and filtering off from the residue; and finally removed as the hydrochlorates, by treatment with dilute

¹ Landolt, "Optische Drehungsvermögen," 169, also 453.

hydrochloric acid in a separatory funnel. The acid solution is carefully neutralized with ammonia, and the quinine and chinchonidine precipitated as tartrates with Rochelle salt.

The precipitation, which is facilitated by stirring, is completed in about an hour. Eighty per cent of the weight of the washed and dried precipitate is composed of the chinchonidine and quinine. A solution convenient for polarizing can be obtained by dissolving the tartrates in either dilute hydrochloric or sulphuric acid. As the rotation of the two optically active substances in solution¹ is the sum of their individual rotatory effects, equations can be derived analogous to those already described in the determination of the optically active constituents of hydrolyzed starch products.

If x is the per cent of quinine to be determined in a known amount of the alkaloid salts and y the per cent of chinchonidine, and $[\alpha]_x$ is the specific rotation of quinine under the conditions of solvent and concentration used in the analysis, $[\alpha]_y$ being the corresponding specific rotation of chinchonidine under like conditions:

$$\text{then,} \quad x + y = 100,$$

$$\text{and} \quad [\alpha]_x \cdot x + [\alpha]_y \cdot y = \alpha$$

(α being the specific rotation of the alkaloid mixture).²

By substituting $100 - x$ for y , Hesse³ develops the fol-

¹ Correction can be made for the tartaric acid set free in solution, if calculation shows that the error is large enough to affect the results ($[\alpha]_D = 1.950 + .13030 q$).

² The percentage is expressed as a whole number, and not decimally as in the equations for starch hydrolysis referred to.

³ *Ann. Chem.* (Liebig), 182, 146, also Oudemans, *ibid.*, 182, 63.

lowing form for the equations expressing the per cents of the alkaloids:

$$x = 100 \frac{[\alpha] - [\alpha]_p}{[\alpha]_x - [\alpha]_p},$$

$$y = 100 \frac{[\alpha]_x - [\alpha]}{[\alpha]_x - [\alpha]_p}.$$

Hesse, as cited by Landolt,¹ also gives a modified form of these equations for the determination of the mixed alkaloids in commercial quinine sulphate in which the rotation values observed for a *defined* condition of tube-length, solvent, and concentration are substituted for the specific rotations. Two grams of the sample are dissolved in 10 cubic centimeters normal hydrochloric acid and the solution made with water to 25 cubic centimeters, l being 2.2 decimeters. The angular rotation of quinine under these conditions is -40.309° , and that of chinchonidine, -26.598° . Hence, for the conditions defined, if the corresponding rotation of the sample is designated by γ , the per cent of quinine will be expressed by $x = \frac{\gamma + 26.598}{-13.711}$, and the per

cent of chinchonidine by $y = \frac{-40.309 - \gamma}{-13.711}$.

Evidently the first set of equations is generally applicable, not only to alkaloids, but to any two optically active substances in solution.

Hesse gives the following values for the specific rotation of quinine hydrochlorate in water with varying quantities of hydrochloric acid, the amount of acid being expressed in "mols" (the molecular equivalent in grams in a liter),

¹ "Optische Drehungsvermögen," 456.

the concentration $\frac{w}{v}$ of the salt being 2 grams per 100 cubic centimeters:

mols HCl	0	1	2	4	10
$[\alpha]_{D^{20}}$	+138.75	+223.2	+225.7	+223.6	+213.9

For a 2 mol solution of acid and a concentration of the quinine salt, varying between 1 and 7 grams per 100 cubic centimeters, the following equation expresses the specific rotation at 15° C.:

$$[\alpha]_{D^{15}} = +229.46 + 2.21 w,$$

or, expressed in the weight of the alkaloid:

$$[\alpha]_{D^{15}} = +280.78 + 3.31 w.$$

The specific rotation of chinchonidine hydrochlorate in water containing 2 mols of hydrochloric acid is for a concentration from 1 to 10:

$$[\alpha]_{D^{20}} = +154.07 + 1.39 w.$$

A method for determining the other alkaloids of chinchona bark, in which polarimetric analysis is used, has apparently not been worked out. The identification of any of the alkaloids after separation, as well as determination of mixtures containing no more than two, is obviously practicable in many cases.

Cocaine. — The polariscope is said to be a valuable aid in determining the purity of this alkaloid, which occasionally is contaminated with dangerous natural impurities, notably cocaine. A polarimetric method of cocaine determination has been developed by Antrick,¹ both for

¹ *Rev. deut. chem. Ges.*, 20, 320.

the extract and the hydrochlorate. The specific rotation of cocaine in chloroform is given by the equation $[\alpha]_{D^{20}} = -16.412 + .00585 p$. In commercial analysis $[\alpha]_D$ is taken as -16.32 . From this is derived the simple equation for the per cent of cocaine, $p = -3.06 \frac{\alpha}{d}$, where l is 2 decimeters.

Cocaine hydrochlorate has a specific rotation in 60 parts of absolute alcohol in 90 parts of water, which is expressed by the following equation:

$$[\alpha]_{D^{20}} = -67.982 + .1583 \alpha$$

On account of the marked change in rotation with varying amounts of solvent, the expression for the per cent is somewhat complicated.

The simplest expression, which is given by Antrick, is:

$$p = -\frac{.7337 \alpha}{d} + \frac{.001454 \alpha^2}{d}$$

Nicotine.—The polarimetric method of Popovici¹ is used in conjunction with Kissling's extraction process. The alkaloid is first obtained in solution by treating about 30 grams of dry pulverized tobacco with 10 cubic centimeters of an alcoholic sodium hydrate solution, made by dissolving 6 grams of sodium hydrate in 100 cubic centimeters of 57 per cent alcohol. The moistened mass is extracted for three hours with ether in a Soxhlet apparatus. The nicotine is precipitated in an impure state from this ether extract by adding 10 cubic centimeters of a strong nitric acid solution of phosphomolybdic acid and shaking vigorously. The ether is decanted from the

¹ *Zeitsch. physiol. Chem.*, 13, 445.

precipitate and water added to a volume of 50 cubic centimeters. The nicotine is finally set free in this alkaline solution by adding 8 grams of dry pulverized barium hydrate. After standing, with frequent shaking, the clear liquor is decanted for polarizing. The simplest equation derived by Landolt is, $w = .704 \frac{a}{l} - .000525 \left(\frac{a}{l}\right)^2$.

Essential Oils. — Most essential oils are optically active, and offer an attractive field for polariscopic investigations. As obtained from plants, these substances are not, however, homogeneous chemical compounds of strictly invariable composition, but differ considerably with the conditions affecting the plant growth and the method of extraction. As a rule, essential oils are complicated combinations of a large number of compounds of very varied nature.

Among the more important well-defined optically active bodies which have been isolated from essential oils are the following terpenes of the general formula, $C_{10}H_{16}$, most of which have been obtained as dextro- and levo-isomers of equal rotating value :

Pinene, or *terebenthene*, the dextro-isomer ($[\alpha]_D = 45.04$) being a characteristic ingredient of American oil of turpentine. The levo-isomer ($[\alpha]_D = -44.95$) is a component of French oil of turpentine.

Camphene, which is also a component of turpentine, a solid at ordinary temperatures, a levo-isomer being characteristic of citronella oil as well as of French turpentine. Camphene is also a component of many other oils, such as rosemary and ginger. Its specific rotation, which seems to be about 60, has not been definitely established.

Limonic, whose dextrorotatory isomer is an ingredient of oils of orange peel, dill, bergamot, and many others of less importance; the levorotatory body, being found in pine-needle oil, has a specific rotation of 105 at 10° (125.6 at 20°).

Sylvestrene ($[\alpha]_D = 17.0^1$), one or the other isomer found in many turpentine oils.

Phellandrene ($[\alpha]_D = 17.6$), found in bitter fennel oil. Is very unstable.

There are two important sesqui-turpenes ($C_{15}H_{24}$):

Cadinene, found in a large number of essential oils, $[\alpha]_D$ in chloroform, at 9.5°C., for a 13 per cent solution, = 98.56.

Caryophyllene, found in cloves and copaiba balsam, $[\alpha]_D = -8.96$.

The following optically active paraffin alcohols have been isolated. They usually are present in the oils as esters of fatty acids.

Linalool ($C_{10}H_{17}OH$), the dextro-isomer in coriander oil, the levo-isomer in many of the citrus oils, as lemon, bergamot, also in sage, thyme, lavender, spearmint, sassafras, and others. The specific rotation has not been satisfactorily determined, probably on account of impurities. It is approximately 15°.

Citronellol ($C_{10}H_{18}OH$), in dextro form in rose and geranium oils, has not had its specific rotation definitely determined. It evidently lies between 2° and 4°.

There are three important aromatic alcohols which have been isolated from essential oils and found to be optically active:

¹ $[\alpha]_D$ in chloroform solution, 66.32.

Terpineol, a tertiary unsaturated alcohol ($C_{10}H_{17}OH$), probably solid when pure, with a rotation, in alcoholic solution, of about 85° . It also exists in the inactive or "racemic" modification, which is identical in its chemical properties. The fact that the isomeric forms exist together in many oils makes the optical determination difficult. Terpeneol is found in cardamom, cajeput, lovage, marjoram, and kuronaji oils among others.

Borneol ($C_{10}H_{17}OH$) occurs in the free state naturally as the solid Borneo camphor and in the levo-isomer as Ngai camphor. It is also found as one or the other isomer in many oils, as cardamom, spike, rosemary, citronella, valerian, sage, and thyme. Like the other alcohols, borneol is often present in the form of a fatty ester. In most solvents, methyl alcohol being an exception, both isomers give a practically constant specific rotation of 37.70° .

Menthol, a saturated secondary alcohol only found in the levo form as a constituent of peppermint oils. Long¹ gives the following rotation constants:

The melted solid at 46° :

$$d_{46} = .8810 \quad [\alpha]_D = -49.86^\circ;$$

alcoholic solution at 20° :

$$[\alpha]_D = -48.247 - .011108 q - .00001870 q^2;$$

benzene solution at 20° :

$$[\alpha]_D = -49.511 - .025634 q - .0008403 q^2$$

(q being the per cent of solvent).

Of the aliphatic terpene aldehydes, only one optically active one is important:

¹ *J. Am. Chem. Soc.*, 14, 149.

Citronellal ($C_9H_{15}CHO$), the dextro-isomer alone having been isolated. It is a constituent of lemon, citronella, eucalyptus, and balm oils ($[\alpha]_{D^{20}} = 12.50$).

Of the large number of aromatic aldehydes which make up the odoriferous constituents of so many ethereal oils, no important optically active ones have been isolated. The following ketones are optically active:

Carvone ($C_9H_{16}CO$), which is found as the dextro-isomer ($[\alpha]_D = 62.65$) in dill and caraway oils, and in the levo form in spearmint and kuromoji ($[\alpha]_D = -62.41$).

Camphor ($C_9H_{16}CO$), besides coming from its principal commercial source, the secretion of the camphor tree, is a constituent of many plants, such as sassafras, cinnamon root, spike, and rosemary. The levo-isomer has been found in feverfew and tansy. The specific rotation of camphor has been calculated by Landolt to be 55.4° . Landolt has also determined the equations for the specific rotation of camphor in the following solvents: benzol, ethyl alcohol, dimethyl aniline, acetic acid, methyl alcohol, monochloroacetic ether, and acetic ether. Benzol is usually the most convenient solvent for polarizing, the rotation formula for this solvent being already given (page 262). The temperature should be kept practically constant at 20° , as changes have marked influence on the rotation.

Fenchone ($C_9H_{16}CO$) much resembles camphor. It is found in fennel as the dextro-isomer, and in thuja in the levo form. The specific rotation of the dextro-isomer has been found to be, in a 10 per cent alcohol solution, 71.8° , the levo-isomer giving -66.9° .

Thujone ($C_9H_{16}CO$), found in the dextro form in wormwood, tansy, and sage. The specific rotation is 21.1° .

Pulegone ($C_9H_{16}CO$) is found in pennyroyal in dextro form ($[\alpha]_{D^{20}} = 22.89^\circ$).

Menthone ($C_{10}H_{18}CO$) occurs in peppermint and geranium oils and in buchu leaves. Like the corresponding alcohol, menthol, it is only found in the levo form ($[\alpha]_{D^{18}} = -28.18^\circ$, $[\alpha]_{D^{24}} = -27.67^\circ$).

This list of some of the more important optically active constituents of the volatile oils is far from complete, but it serves to indicate the variety and complexity of the combinations which make up these interesting products, and the immense field for research which is presented to the polariscopist. Rigidly formulated methods of procedure cannot be given for the investigation of even the common essential oils, but the analyst must combine an acquaintance with the local conditions of their production with an intimate knowledge of the chemical composition of the oil and its probable adulterants.

The case of oil of lemon will illustrate this point. The bulk of this oil comes from southern Italy and Sicily. The oil from Messina has a specific rotation at $20^\circ C$. of 59° , or from some years' crops even less. The oil from Syracuse has a rotation sometimes as high as 67° . Other districts produce oils with rotation values lying between these extremes, the average being about 60° . Turpentine is often an adulterant. If the turpentine is American, its specific rotation is usually about 6° ; if French, -30° . Substituting the average rotation value of 60° for the lemon oil and the value for turpentine, when chemical and physical tests have shown which kind is present, in the general equation discussed under chinchona alkaloids, the proportion of the adulterant can be determined. If, however, the

strongly rotating oil of *orange* ($[\alpha]_D = 98^\circ$) has been added to disguise the turpentine, a further separation must be made by steam distillation, when the lower boiling turpentine will in the main distill off in the first fraction and so be detected by the polariscope by the low rotation. As temperature affects the rotations considerably, polarizations must be made at 20° .

If the oil is known to be pure, the polariscope can be used to determine the strength of an alcoholic solution,¹ such as a lemon flavoring extract for instance, by a simple application of the principles of polarimetric analysis already familiar. Such a method is in practice.

For a full exposition of the chemistry and analysis of ethereal oils, see Gildermeister and Hoffmann's work on the volatile oils, translated by Kremers. The data of the optical constants, as far as they are known, of some four hundred oils are given in this work. See also the data given by Schimmel & Co. in Landolt's "Optische Drehungsvermögen," page 578.

Heavy Oils. — The polariscope has comparatively little application in the chemistry of the heavy oils. Rosin oil, a product of destructive distillation of turpentine residuums (rosins) is often used as an adulterant of the fatty oils on account of its cheapness. The optical activity of this oil

¹ Many cheap lemon extracts are made from "washed" or "terpeneless" oil, being solutions of practically pure citral made from oil of lemon or oil of citronella (lemon-grass) by distilling off the low-boiling and optically active terpenes. Citral is soluble in *dilute* alcohol, so that the expense of manufacture is greatly economized. Other terpeneless essential oils are also made, and many oils are improved by this process, as the terpenes are usually not the characteristic odoriferous principles, and the solubility of the oil is increased. The distilled terpenes are used as adulterants of pure oils.

serves for its detection. The greatest difficulty in polarimetric determinations of the heavy oils is in clarifying, as the usual methods cause decomposition of the product, and it is often impossible to isolate the oil by distillation. Often the only practicable way is to dilute with some solvent, which of course greatly diminishes the precision of the measurements, especially as the rotations are as a rule small.

Gill and Mason¹ have used the polariscope as an aid to the detection of mineral oil in the distilled grease oleines recovered from wool scouring. These "oleines" as wool oils are of importance in the woolen industries, where they are used for oiling wool preparatory to spinning. As the specific rotation of the unmixed grease lies between 16° and 18°, the addition of the optically inactive² adulterant is readily shown. The oil was diluted with ten parts of benzol for polarizing.

Gallotannic Acid. — Wood-Smith and Regis have worked up a method for determining gallotannic acid in tanning materials, which is based on the change of rotation in a gelatin solution, which has been clarified with white of egg, by its combination with gallotannic acid. As the method is quite empirical in its details, the reader is referred to the original paper (*Analyst*, 23, 33).

Tartaric Acid and Tartrates. — K. B. and F. B. Kenrick³ have developed methods for the determination of tartaric acid and tartrates, particularly devised for baking powders and effervescent mixtures. The authors have made an

¹ *J. Am. Chem. Soc.*, 26, 665.

² Gill and Mason found a very slight optical activity in some petroleum oils.

³ *J. Am. Chem. Soc.*, 24, 928.

extensive investigation of the influence of many common salts and acids on solutions containing tartaric acid in which sugar or starch is present or absent. Experiment showed that when soluble tartrates or calcium tartrate were alone present, and substances disturbing the rotation, like iron or alumina, were absent, the rotation of the tartrate in an excess of ammonia was proportional to the concentration and could be expressed as tartaric acid by the following equation, $w = .00519x$; x being the angular rotation for the sodium light in *minutes* when the concentration of the tartrate was about 2 grams in 50 cubic centimeters of ammonia solution containing an excess no more than equivalent to 2 cubic centimeters of the concentrated ammonia. If the mixture contains the insoluble calcium tartrate, the mixture must be dissolved in a dilute solution of hydrochloric acid (20 drops in 30 cubic centimeters of water). The solution is effected by heating gently. Four cubic centimeters of ammonia are added to the solution and about .2 gram of sodium phosphate; the mixture is cooled, made up to 50 cubic centimeters, and filtered. The sodium phosphate precipitates the lime, and is not absolutely necessary unless the proportion of calcium is large, when it prevents the latter from crystallizing out of the solution. A 2-decimeter tube is used.

If sugar is present in the mixture, it must be determined by the Clerget method, and its rotation allowed for. If magnesium be present, as it is in many effervescent mixtures, it must first be precipitated by sodium phosphate and ammonia, as it influences the rotation values of both the tartaric acid and the sugar. Further, it is necessary to add the appropriate amount of acid for inverting, inde-

pendently of the amount which goes into combination with the bases present to free any organic acids present. In this case an amount of substance, corresponding to about 8 grams of substance or 5 grams of sugar, is made up to 100 cubic centimeters; 25 cubic centimeters of this solution is put into a 50 cubic-centimeter flask, and if alkaline neutralized with hydrochloric acid, using methyl orange as an indicator; 1 cubic centimeter of ammonia is added, and the solution made up to mark and polarized.

The amount of hydrochloric acid necessary to set free any combined organic acids, and, consequently, not available as an inverting agent, is determined by adding the acid to a second portion of 25 cubic centimeters of the original solution, to which methyl violet has been added till the solution just turns green, showing an excess of the free mineral acid. A third 25 cubic centimeters of the solution, placed in a 50 cubic-centimeter flask, is now inverted by adding just the amount of acid necessary to set free the organic acids, in addition to that necessary to invert, which is 2.5 cubic centimeters. The Clerget process is carried out in the usual way, and, after cooling, the acid is neutralized with ammonia, 1 cubic centimeter excess added, and the solution polarized after making up to the 50 mark. The calculation formula given by the authors is, for sugar, $x = \frac{2(a-b)1.254}{142-.5t}$, a and b being expressed in *minutes*. The *rotation* of the tartaric acid is $x = 2a - 79.7\%$, and the weight of acid, $w = 4(.00519)x$.

If magnesium is present, only 10 cubic centimeters of the original solution, made up as described, containing about 8 grams of tartrate in 100 cubic centimeters, is used, and

the magnesium precipitated by using as nearly as possible the exact amount of reagent necessary; the precipitate being removed by means of a filter pump so that the wash waters, which are to be polarized and inverted, are reduced to as small a bulk as possible, not to exceed 100 cubic centimeters, to which the solution is made up in this case. Twenty-five cubic centimeters are tested to determine the amount of inverting acid necessary, as already described, and 25 cubic centimeters prepared and inverted in the manner also described, and made up to 50 cubic centimeters. The equations in this case become:

$$z = \frac{10(a - 2b)1.254}{142 - .5t},$$

$$x = 10a - 79.7z,$$

$$w = 4(.00519x).$$

If iron or alumina salts are present, the polarizations must be made in neutral ammonium molybdate solution; the solution must be strictly neutral and phosphates must be removed. As the molybdic acid greatly increases the rotation of the tartrate, an amount of sample containing only .2 gram of tartrate is taken in a dry flask, with 10 cubic centimeters citric acid ($c = \frac{5}{8} \frac{0}{0}$) and 10 cubic centimeters ammonium molybdate ($c = \frac{4}{2} \frac{4}{5} \frac{0}{0}$), and allowed to react for five minutes, the flask being shaken occasionally. Then 5 cubic centimeters of magnesium sulphate solution ($c = \frac{8}{8} \frac{0}{0}$) and 10 cubic centimeters ammonia (165 cubic centimeters ammonia, $d = .924$, in 500 cubic centimeters). These solutions are exactly measured, making the volume 35 cubic centimeters. If the substance tested is a liquid, allowance for its volume is made by taking less ammonia

solution. Within an hour the solution is filtered and 20 cubic centimeters measured into a 50 cubic-centimeter flask, and dilute hydrochloric acid added to faint acidity as shown by methyl orange. Ten cubic centimeters of the molybdate solution are then added, and the whole made up with water to 50 cubic centimeters. The solution is now polarized and filtered, if necessary, in a 2 decimeter tube. The specific rotations of tartrates in neutral molybdate solutions are found by the authors to be practically constant at different concentrations. The equation for determining tartaric acid under these circumstances is $\alpha = 0.00121 x$, being, as in all the equations given, the angular rotation of sodium light expressed in minutes.

The author has had no experience with many of these methods, but mentions them as illustrations of how such determinations are worked out. In the present state of knowledge of the optical constants of many compounds which can be determined by polarimetric analysis, it will be necessary for the analyst to devise his own method for the case at hand. This should not be difficult with a proper comprehension of the principles set forth. In fact, the aim in writing this little book has been in the main to show how these principles have been successfully applied, and to assist the reader in acquiring knowledge which will enable him to attack effectively any problem of this kind which comes to hand. It is confidently believed that such knowledge will greatly extend the use of the polariscope in the chemical laboratory. If this book does its part in aiding this extension, it has not failed of its purpose.

APPENDIX

BIBLIOGRAPHY OF THE MORE IMPORTANT WORKS OF REFERENCE

General Chemistry of Carbohydrates.

- Tollens. *Handbuch der Kohlenhydrate*. Vol. I. 1888. Vol. II
(Supplementary). 1895. (Contains bibliography of original
papers.)
- Macquenne. *Les Sucres et principaux Dérivés*. 1900.
- Von Lippmann. *Chemie der Zuckerarten*. 1904. (3d Ed.)
(Bibliography.)

Technology of Sucrose.

- Wiley. *Bulletins of Division of Chemistry, United States Depart-
ment of Agriculture.*
- (Cane Sugar and Sorghum), 2, 3, 5, 6, 8, 14, 17.
(Sorghum), 20, 26, 29, 34, 37, 40.
(Beet Sugar), 27, 30, 33, 36, 39, 72, 52 (revised), 64, 78.
Also Special Reports, 1897, 1898, 1899.
(Sugar Producing Plants), 18.
- Spencer. (Cane Sugar), *ibid.* 11, 15, 21.
- Crampton. (Cane Sugar), *ibid.* 22.
- Edson. (Cane Sugar), *ibid.* 23.
- Basset. *Guide pratique du Fabricant de Sucre*. 1882.
- Harsin Déon. *Fabrication de Sucre*. 1882.
- Lock and Newlands Bros. *Handbook for Planters and Sugar
Manufacturers*. 1888.
- Von Lippmann. *Geschichte des Zuckers*. 1890.
- Roth. *Literature of Sugar*. 1890 (Bibliography).
- Watts. *An Introductory Manual for Sugar Growers*. 1893.

- Beaudet-Pellet-Saillard. Traité de la Fabrication du Sucre. 1894.
 Stubbs. Sugar Cane (Vol. I). The Chemistry and Manufacture of
 Sugar (Vol. II). 1897.
 Horsin-Déon. Le Sucre et l'Industrie sucrière. 1894.
 Stohmann. Zuckerfabrikation. (4th Ed.) 1899.
 Saltler. Handbook of Industrial Organic Chemistry. (3d Ed.)
 1900.
 Deerr. Sugar House Notes and Tables. 1900.
 Bass. Cane Sugar (English and Spanish text). 1901. (2d Ed.)
 Geschwind et Sellier. La Betterave. 1902.
 Quivy. L'Épuration des Jus sucrés par Electricité. 1902.
 Mittelstaedt. Aus der Praxis der Zuckerindustrie. 1902.
 Prinsen-Geerligs. On Cane Sugar. 1903. (2d Ed.)
 Teyssier. Fabrication du Sucre. 1904.
 Stillman. Cane Sugar Machinery (English and Spanish text).
 1904.
 Mackintosh. Technology of Sugar. 1904.
 Claassen. Die Zuckerfabrikation. 1904.
 Colsen. Culture Industrielle de la Canne à Sucre aux Isles Hawai.
 (2d Ed.) 1905.
 Thorp. Outlines of Industrial Chemistry. (2d Ed.) 1905.

Periodicals of Sugar Technology.

- Zeitschrift des Vereins der deutschen Zuckerindustrie.
 Neue Zeitschrift für Rübenzuckerindustrie.
 Stammer. Jahrsbericht der Zuckerfabrikation.
 Bulletin de l'Association des Chimistes de Sucrerie et de Distillation.
 The Louisiana Sugar Planter and Sugar Manufacturer.
 The Hawaiian Planter's Monthly.
 The Sugar Cane. (British.)
 Die Deutsche Zuckerindustrie.
 Centralblatt für die Zuckerindustrie.
 Österreichisch-Ungarische Zeitschrift für Zuckerindustrie (etc.).

La Sucrerie Belge.

Zeitschrift für Zuckerindustrie in Böhmen.

Analytical Methods and Chemical Control of Sugar (sucrose) Manufacture.

Spencer. Handbook for Sugar Manufacturers. (Cane Sugar.)
1889.

Tinker. Manual of Sugar Analysis. 1890.

Wichmann. Sugar Analysis. 1890.

Sidersky. Traité d'Analyse der Matières sucrées. 1890.

Steyn. Die Untersuchungen der Zuckers und Zuckerhaltigen
Stoffe. 1893.

Wiley. Principles and Practice of Agricultural Chemical Analysis.
1896.

Peffer. Beet Sugar Analysis. 1897.

Spencer. Handbook for Beet-sugar Manufacturers. 1897.

Sidersky. Aide-Mémoire de Sucrerie. 1898.

Broquet and Dethier. Manuel d'Analyse Chimique l'Usage des
Fabricants de Sucre. 1898.

United States Treasury. Bulletin 2113. Revised Regulations
governing the Sampling and Classification of Imported
Sugars and Molasses. 1899.

Frühling. Anleitung zur Untersuchung der für die Zuckerindus-
trie in Betracht kommenden Rohmaterialien, Produkte,
Nebenprodukten und Hilfssubstanzen. (6th Ed.) 1903.

Stolle. Handbuch für Zuckerfabriks Chemiker. 1904.

Morse. Calculations used in Cane-sugar Factories. 1904.

Lactose. Analytic Methods.

Wiley. Principles and Practice of Agricultural Chemical Analysis.
Vol. III. 1896.

United States Department of Agriculture—Division of Chemistry.
Bulletin 46. (Revised.)

Starch and Starch Products — Analytic and Technical.

- Wagner. Stärkefabrikation. 1886.
 Birnkamm. Stärkezucker. 1886.
 National Academy of Sciences. Report on Glucose. 1884.
 Fritsch. La Fecule. 1890.
 Griffiths. Principal Starches used as Food. (Photomicrographs.)
 1892.
 Saare. Fabrikation de Kartoffelstärke. 1897.
 Sadtler. Handbook of Industrial Organic Chemistry. 1900.
 Heron. Thorpe's Dictionary of Applied Chemistry. (Articles,
 "Sugar" and "Starch.") 1900.
 O'Sullivan and Heron. *Ibid.* Articles, "Dextrin," "Dextrose,"
 and "Maltose."
 Bersch. Die Fabrikation von Stärkezucker, Dextrin, Zuckercouleur
 und Invertzucker. 1901.
 Thorp. Outlines of Industrial Chemistry. (2d Ed.) 1905.
 Wiley. (Cassava and Potato Starch.) Bulletin of Division of
 Chemistry, United States Department of Agriculture, 44 and 58.

Sugar Analysis applied to Brewing.

- Moritz and Morris. Text-book of the Science of Brewing. 1890.
 Prior. Maltz und Bier. 1896.
 Brown (Adrian). Laboratory Studies for Brewing Students. 1904.

Polarimetric Methods in Food Analysis.

- Leach. Food Inspection and Analysis. 1904.
 United States Department of Agriculture — Division of Chemistry
 Bulletins 46 (revised), 65, and 66. 1902.

Polarimetric Methods applied to Essential Oils and Drugs.

- Allen. Commercial Organic Analysis. Vol. III, Part 2. 1892.
 Parry. The Chemistry of the Essential Oils and Artificial Per-
 fumes. 1899.

Gildemeister and Hoffmann. (Translated by Kremers.) *The Volatile Oils.* 1902.

Optics of the Microscope and General Theoretical Principles.

Tyndall. *Notes on Light.* 1882.

Lambert. *Dioptrik und Drehungsvermögen.* 1898.

Preston. *Theory of Light.* (3d Ed.) 1901.

Lambert. (Translated by Long.) *Optical Rotation of Organic Substances.* 1902.

Heros. *Thorp's Dictionary of Applied Chemistry.* (Article, "Sugar"), section, "Saccharimetry.") (Excellent exposition of whole subject.)

TABLES

I.—HYDROMETER TABLE FOR AQUEOUS SUGAR SOLUTIONS AT 17.5° C.

(Specific gravity referred to water at 17.5°)

DEGREES BRIX	SPECIFIC GRAVITY ($d_{17.5}^{17.5}$)	DEGREES BAUME	DEGREES BRIX	SPECIFIC GRAVITY ($d_{17.5}^{17.5}$)	DEGREES BAUME
0.0	1.00000	0.00	4.0	1.01570	2 27
0.1	1.00038	0.06	4.1	1.01610	2.33
0.2	1.00077	0.11	4.2	1.01650	2 38
0.3	1.00116	0.17	4.3	1.01690	2.44
0.4	1.00155	0.23	4.4	1.01730	2.50
0.5	1.00193	0.28	4.5	1.01770	2.55
0.6	1.00232	0.34	4.6	1.01810	2.61
0.7	1.00271	0.40	4.7	1.01850	2.67
0.8	1.00310	0.45	4.8	1.01890	2.72
0.9	1.00349	0.51	4.9	1.01930	2.78
1.0	1.00388	0.57	5.0	1.01970	2.84
1.1	1.00427	0.63	5.1	1.02010	2.89
1.2	1.00466	0.68	5.2	1.02051	2.95
1.3	1.00505	0.74	5.3	1.02091	3.01
1.4	1.00544	0.80	5.4	1.02131	3.06
1.5	1.00583	0.85	5.5	1.02171	3.12
1.6	1.00622	0.91	5.6	1.02211	3.18
1.7	1.00662	0.97	5.7	1.02252	3 23
1.8	1.00701	1.02	5.8	1.02292	3.29
1.9	1.00740	1.08	5.9	1.02333	3.35
2.0	1.00779	1.14	6.0	1.02373	3.40
2.1	1.00818	1.19	6.1	1.02413	3.46
2.2	1.00858	1.25	6.2	1.02454	3.52
2.3	1.00897	1.31	6.3	1.02494	3.57
2.4	1.00936	1.36	6.4	1.02535	3.63
2.5	1.00976	1.42	6.5	1.02575	3.69
2.6	1.01015	1.48	6.6	1.02616	3.74
2.7	1.01055	1.53	6.7	1.02657	3.80
2.8	1.01094	1.59	6.8	1.02697	3.86
2.9	1.01134	1.65	6.9	1.02738	3.91
3.0	1.01173	1.70	7.0	1.02779	3.97
3.1	1.01213	1.76	7.1	1.02819	4.03
3.2	1.01252	1.82	7.2	1.02860	4.08
3.3	1.01292	1.87	7.3	1.02901	4.14
3.4	1.01332	1.93	7.4	1.02942	4.20
3.5	1.01371	1.99	7.5	1.02983	4.25
3.6	1.01411	2.04	7.6	1.03024	4.31
3.7	1.01451	2.10	7.7	1.03064	4.37
3.8	1.01491	2.16	7.8	1.03105	4.42
3.9	1.01531	2.21	7.9	1.03146	4.48

DEGREES BRIX	SPECIFIC GRAVITY ($d_{17.5}^{17.5}$)	DEGREES BAUMÉ	DEGREES BRIX	SPECIFIC GRAVITY ($d_{17.5}^{17.5}$)	DEGREES BAUMÉ
8.0	1.03187	4.53	13.0	1.05276	7.36
8.1	1.03228	4.59	13.1	1.05318	7.41
8.2	1.03270	4.65	13.2	1.05361	7.47
8.3	1.03311	4.70	13.3	1.05404	7.53
8.4	1.03352	4.76	13.4	1.05446	7.58
8.5	1.03393	4.82	13.5	1.05489	7.64
8.6	1.03434	4.87	13.6	1.05532	7.69
8.7	1.03475	4.93	13.7	1.05574	7.75
8.8	1.03517	4.99	13.8	1.05617	7.81
8.9	1.03558	5.04	13.9	1.05660	7.86
9.0	1.03599	5.10	14.0	1.05703	7.92
9.1	1.03640	5.16	14.1	1.05746	7.98
9.2	1.03682	5.21	14.2	1.05789	8.03
9.3	1.03723	5.27	14.3	1.05831	8.09
9.4	1.03765	5.33	14.4	1.05874	8.14
9.5	1.03806	5.38	14.5	1.05917	8.20
9.6	1.03848	5.44	14.6	1.05960	8.26
9.7	1.03889	5.50	14.7	1.06003	8.31
9.8	1.03931	5.55	14.8	1.06047	8.37
9.9	1.03972	5.61	14.9	1.06090	8.43
10.0	1.04014	5.67	15.0	1.06133	8.48
10.1	1.04055	5.72	15.1	1.06176	8.54
10.2	1.04097	5.78	15.2	1.06219	8.59
10.3	1.04139	5.83	15.3	1.06262	8.65
10.4	1.04180	5.89	15.4	1.06306	8.71
10.5	1.04222	5.95	15.5	1.06349	8.76
10.6	1.04264	6.00	15.6	1.06392	8.82
10.7	1.04306	6.06	15.7	1.06436	8.88
10.8	1.04348	6.12	15.8	1.06479	8.93
10.9	1.04390	6.17	15.9	1.06522	8.99
11.0	1.04431	6.23	16.0	1.06566	9.04
11.1	1.04473	6.29	16.1	1.06609	9.10
11.2	1.04515	6.34	16.2	1.06653	9.16
11.3	1.04557	6.40	16.3	1.06696	9.21
11.4	1.04599	6.46	16.4	1.06740	9.27
11.5	1.04641	6.51	16.5	1.06783	9.33
11.6	1.04683	6.57	16.6	1.06827	9.38
11.7	1.04726	6.62	16.7	1.06871	9.44
11.8	1.04768	6.68	16.8	1.06914	9.49
11.9	1.04810	6.74	16.9	1.06958	9.55
12.0	1.04852	6.79	17.0	1.07002	9.61
12.1	1.04894	6.85	17.1	1.07046	9.66
12.2	1.04937	6.91	17.2	1.07090	9.72
12.3	1.04979	6.96	17.3	1.07133	9.77
12.4	1.05021	7.02	17.4	1.07177	9.83
12.5	1.05064	7.08	17.5	1.07221	9.89
12.6	1.05106	7.13	17.6	1.07265	9.94
12.7	1.05149	7.19	17.7	1.07309	10.00
12.8	1.05191	7.24	17.8	1.07353	10.06
12.9	1.05233	7.30	17.9	1.07397	10.11

DEGREES DIAZ	SPECIFIC GRAVITY (n_D^{20})	DEGREES HAUME	DEGREES BRIX	SPECIFIC GRAVITY ($n_D^{17.5}$)	DEGREES HAUME
18.0	1.07111	10.17	23.0	1.09686	12.96
18.1	1.07123	10.22	23.1	1.09732	13.02
18.2	1.07135	10.28	23.2	1.09777	13.07
18.3	1.07147	10.33	23.3	1.09823	13.13
18.4	1.07159	10.39	23.4	1.09869	13.19
18.5	1.07172	10.45	23.5	1.09915	13.24
18.6	1.07184	10.50	23.6	1.09961	13.30
18.7	1.07197	10.56	23.7	1.10007	13.35
18.8	1.07209	10.62	23.8	1.10053	13.41
18.9	1.07221	10.67	23.9	1.10099	13.46
19.0	1.07234	10.73	24.0	1.10145	13.52
19.1	1.07246	10.78	24.1	1.10191	13.58
19.2	1.07259	10.84	24.2	1.10237	13.63
19.3	1.07271	10.90	24.3	1.10283	13.69
19.4	1.07284	10.95	24.4	1.10329	13.74
19.5	1.07296	11.01	24.5	1.10375	13.80
19.6	1.07309	11.06	24.6	1.10421	13.85
19.7	1.07321	11.12	24.7	1.10468	13.91
19.8	1.07334	11.18	24.8	1.10514	13.96
19.9	1.07346	11.23	24.9	1.10560	14.02
20.0	1.07359	11.29	25.0	1.10607	14.08
20.1	1.07371	11.34	25.1	1.10653	14.13
20.2	1.07384	11.40	25.2	1.10700	14.19
20.3	1.07396	11.45	25.3	1.10746	14.24
20.4	1.07409	11.51	25.4	1.10793	14.30
20.5	1.07421	11.57	25.5	1.10839	14.35
20.6	1.07434	11.62	25.6	1.10886	14.41
20.7	1.07446	11.68	25.7	1.10932	14.47
20.8	1.07459	11.73	25.8	1.10979	14.52
20.9	1.07471	11.79	25.9	1.11026	14.58
21.0	1.07484	11.85	26.0	1.11072	14.63
21.1	1.07496	11.90	26.1	1.11119	14.69
21.2	1.07509	11.96	26.2	1.11166	14.74
21.3	1.07521	12.01	26.3	1.11213	14.80
21.4	1.07534	12.07	26.4	1.11259	14.85
21.5	1.07546	12.13	26.5	1.11306	14.91
21.6	1.07559	12.18	26.6	1.11353	14.97
21.7	1.07571	12.24	26.7	1.11400	15.02
21.8	1.07584	12.29	26.8	1.11447	15.08
21.9	1.07596	12.35	26.9	1.11494	15.13
22.0	1.07609	12.40	27.0	1.11541	15.19
22.1	1.07621	12.46	27.1	1.11588	15.24
22.2	1.07634	12.52	27.2	1.11635	15.30
22.3	1.07646	12.57	27.3	1.11682	15.35
22.4	1.07659	12.63	27.4	1.11729	15.41
22.5	1.07671	12.68	27.5	1.11776	15.46
22.6	1.07684	12.74	27.6	1.11824	15.52
22.7	1.07696	12.80	27.7	1.11871	15.58
22.8	1.07709	12.85	27.8	1.11918	15.63
22.9	1.07721	12.91	27.9	1.11965	15.69

DEGREES BRIX	SPECIFIC GRAVITY ($d_{17.5}^{17.5}$)	DEGRES BAUME	DEGREES BRIX	SPECIFIC GRAVITY ($d_{17.3}^{17.3}$)	DEGRES BAUME
28.0	I.12013	15.74	33.0	I.14423	18.50
28.1	I.12060	15.80	33.1	I.14472	18.56
28.2	I.12107	15.85	33.2	I.14521	18.61
28.3	I.12155	15.91	33.3	I.14570	18.67
28.4	I.12202	15.96	33.4	I.14620	18.72
28.5	I.12250	16.02	33.5	I.14669	18.78
28.6	I.12297	16.07	33.6	I.14718	18.83
28.7	I.12345	16.13	33.7	I.14767	18.89
28.8	I.12393	16.18	33.8	I.14817	18.94
28.9	I.12440	16.24	33.9	I.14866	19.00
29.0	I.12488	16.30	34.0	I.14915	19.05
29.1	I.12536	16.35	34.1	I.14965	19.11
29.2	I.12583	16.41	34.2	I.15014	19.16
29.3	I.12631	16.46	34.3	I.15064	19.22
29.4	I.12679	16.52	34.4	I.15113	19.27
29.5	I.12727	16.57	34.5	I.15163	19.33
29.6	I.12775	16.63	34.6	I.15213	19.38
29.7	I.12823	16.68	34.7	I.15262	19.44
29.8	I.12871	16.74	34.8	I.15312	19.49
29.9	I.12919	16.79	34.9	I.15362	19.55
30.0	I.12967	16.85	35.0	I.15411	19.60
30.1	I.13015	16.90	35.1	I.15461	19.66
30.2	I.13063	16.96	35.2	I.15511	19.71
30.3	I.13111	17.01	35.3	I.15561	19.76
30.4	I.13159	17.07	35.4	I.15611	19.82
30.5	I.13207	17.12	35.5	I.15661	19.87
30.6	I.13255	17.18	35.6	I.15710	19.93
30.7	I.13304	17.23	35.7	I.15760	19.98
30.8	I.13352	17.29	35.8	I.15810	20.04
30.9	I.13400	17.35	35.9	I.15861	20.09
31.0	I.13449	17.40	36.0	I.15911	20.15
31.1	I.13497	17.46	36.1	I.15961	20.20
31.2	I.13545	17.51	36.2	I.16011	20.26
31.3	I.13594	17.57	36.3	I.16061	20.31
31.4	I.13642	17.62	36.4	I.16111	20.37
31.5	I.13691	17.68	36.5	I.16162	20.42
31.6	I.13740	17.73	36.6	I.16212	20.48
31.7	I.13788	17.79	36.7	I.16262	20.53
31.8	I.13837	17.84	36.8	I.16313	20.59
31.9	I.13885	17.90	36.9	I.16363	20.64
32.0	I.13934	17.95	37.0	I.16413	20.70
32.1	I.13983	18.01	37.1	I.16464	20.75
32.2	I.14032	18.06	37.2	I.16514	20.80
32.3	I.14081	18.12	37.3	I.16565	20.86
32.4	I.14129	18.17	37.4	I.16616	20.91
32.5	I.14178	18.23	37.5	I.16666	20.97
32.6	I.14227	18.28	37.6	I.16717	21.02
32.7	I.14276	18.34	37.7	I.16768	21.08
32.8	I.14325	18.39	37.8	I.16818	21.13
32.9	I.14374	18.45	37.9	I.16869	21.19

TABLES

DEGREES BRIX	SPECIFIC GRAVITY ($d_{17.5}^{17.5}$)	DEGREES BAUMÉ	DEGREES BRIX	SPECIFIC GRAVITY ($d_{17.5}^{17.5}$)	DEGREES BAUMÉ
38.0	I.16920	21.24	43.0	I.19505	23.96
38.1	I.16971	21.30	43.1	I.19558	24.01
38.2	I.17022	21.35	43.2	I.19611	24.07
38.3	I.17072	21.40	43.3	I.19663	24.12
38.4	I.17123	21.46	43.4	I.19716	24.17
38.5	I.17174	21.51	43.5	I.19769	24.23
38.6	I.17225	21.57	43.6	I.19822	24.28
38.7	I.17276	21.62	43.7	I.19875	24.34
38.8	I.17327	21.68	43.8	I.19927	24.39
38.9	I.17379	21.73	43.9	I.19980	24.44
39.0	I.17430	21.79	44.0	I.20033	24.50
39.1	I.17481	21.84	44.1	I.20086	24.55
39.2	I.17532	21.90	44.2	I.20139	24.61
39.3	I.17583	21.95	44.3	I.20192	24.66
39.4	I.17635	22.00	44.4	I.20245	24.71
39.5	I.17686	22.06	44.5	I.20299	24.77
39.6	I.17737	22.11	44.6	I.20352	24.82
39.7	I.17789	22.17	44.7	I.20405	24.88
39.8	I.17840	22.22	44.8	I.20458	24.93
39.9	I.17892	22.28	44.9	I.20512	24.98
40.0	I.17943	22.33	45.0	I.20565	25.04
40.1	I.17995	22.38	45.1	I.20618	25.09
40.2	I.18046	22.44	45.2	I.20672	25.14
40.3	I.18098	22.49	45.3	I.20725	25.20
40.4	I.18150	22.55	45.4	I.20779	25.25
40.5	I.18201	22.60	45.5	I.20832	25.31
40.6	I.18253	22.66	45.6	I.20886	25.36
40.7	I.18305	22.71	45.7	I.20939	25.41
40.8	I.18357	22.77	45.8	I.20993	25.47
40.9	I.18408	22.82	45.9	I.21046	25.52
41.0	I.18460	22.87	46.0	I.21100	25.57
41.1	I.18512	22.93	46.1	I.21154	25.63
41.2	I.18564	22.98	46.2	I.21208	25.68
41.3	I.18616	23.04	46.3	I.21261	25.74
41.4	I.18668	23.09	46.4	I.21315	25.79
41.5	I.18720	23.15	46.5	I.21369	25.84
41.6	I.18772	23.20	46.6	I.21423	25.90
41.7	I.18824	23.25	46.7	I.21477	25.95
41.8	I.18877	23.31	46.8	I.21531	26.00
41.9	I.18929	23.36	46.9	I.21585	26.06
42.0	I.18981	23.42	47.0	I.21639	26.11
42.1	I.19033	23.47	47.1	I.21693	26.17
42.2	I.19086	23.52	47.2	I.21747	26.22
42.3	I.19138	23.58	47.3	I.21802	26.27
42.4	I.19190	23.63	47.4	I.21856	26.33
42.5	I.19243	23.69	47.5	I.21910	26.38
42.6	I.19295	23.74	47.6	I.21964	26.43
42.7	I.19348	23.79	47.7	I.22019	26.49
42.8	I.19400	23.85	47.8	I.22073	26.54
42.9	I.19453	23.90	47.9	I.22127	26.59

DEGREES BRIX	SPECIFIC GRAVITY ($d_{17.5}^{17.5}$)	DEGREES BAUMÉ	DEGREES BRIX	SPECIFIC GRAVITY ($d_{17.5}^{17.5}$)	DEGREES BAUMÉ
48.0	I.22182	26.65	53.0	I.24951	29.31
48.1	I.22236	26.70	53.1	I.25008	29.36
48.2	I.22291	26.75	53.2	I.25064	29.42
48.3	I.22345	26.81	53.3	I.25120	29.47
48.4	I.22400	26.86	53.4	I.25177	29.52
48.5	I.22455	26.92	53.5	I.25233	29.57
48.6	I.22509	26.97	53.6	I.25290	29.63
48.7	I.22564	27.02	53.7	I.25347	29.68
48.8	I.22619	27.08	53.8	I.25403	29.73
48.9	I.22673	27.13	53.9	I.25460	29.79
49.0	I.22728	27.18	54.0	I.25517	29.84
49.1	I.22783	27.24	54.1	I.25573	29.89
49.2	I.22838	27.29	54.2	I.25630	29.94
49.3	I.22893	27.34	54.3	I.25687	30.00
49.4	I.22948	27.40	54.4	I.25744	30.05
49.5	I.23003	27.45	54.5	I.25801	30.10
49.6	I.23058	27.50	54.6	I.25857	30.16
49.7	I.23113	27.56	54.7	I.25914	30.21
49.8	I.23168	27.61	54.8	I.25971	30.26
49.9	I.23223	27.66	54.9	I.26028	30.31
50.0	I.23278	27.72	55.0	I.26086	30.37
50.1	I.23334	27.77	55.1	I.26143	30.42
50.2	I.23389	27.82	55.2	I.26200	30.47
50.3	I.23444	27.88	55.3	I.26257	30.53
50.4	I.23499	27.93	55.4	I.26314	30.58
50.5	I.23555	27.98	55.5	I.26372	30.63
50.6	I.23610	28.04	55.6	I.26429	30.68
50.7	I.23666	28.09	55.7	I.26486	30.74
50.8	I.23721	28.14	55.8	I.26544	30.79
50.9	I.23777	28.20	55.9	I.26601	30.84
51.0	I.23832	28.25	56.0	I.26658	30.89
51.1	I.23888	28.30	56.1	I.26716	30.95
51.2	I.23943	28.36	56.2	I.26773	31.00
51.3	I.23999	28.41	56.3	I.26831	31.05
51.4	I.24055	28.46	56.4	I.26889	31.10
51.5	I.24111	28.51	56.5	I.26946	31.16
51.6	I.24166	28.57	56.6	I.27004	31.21
51.7	I.24222	28.62	56.7	I.27062	31.26
51.8	I.24278	28.67	56.8	I.27120	31.31
51.9	I.24334	28.73	56.9	I.27177	31.37
52.0	I.24390	28.78	57.0	I.27235	31.42
52.1	I.24446	28.83	57.1	I.27293	31.47
52.2	I.24502	28.89	57.2	I.27351	31.52
52.3	I.24558	28.94	57.3	I.27409	31.58
52.4	I.24614	28.99	57.4	I.27467	31.63
52.5	I.24670	29.05	57.5	I.27525	31.68
52.6	I.24726	29.10	57.6	I.27583	31.73
52.7	I.24782	29.15	57.7	I.27641	31.79
52.8	I.24839	29.20	57.8	I.27699	31.84
52.9	I.24895	29.26	57.9	I.27758	31.89

DEGREES BRIX	SPECIFIC GRAVITY ($d_{17.5}^{17.5}$)	DEGREES BAUME	DEGREES BRIX	SPECIFIC GRAVITY ($d_{17.5}^{17.5}$)	DEGREES BAUME
58.0	1.27816	31.94	63.0	1.30777	34.54
58.1	1.27874	32.00	63.1	1.30837	34.59
58.2	1.27932	32.05	63.2	1.30897	34.65
58.3	1.27991	32.10	63.3	1.30958	34.70
58.4	1.28049	32.15	63.4	1.31018	34.75
58.5	1.28107	32.20	63.5	1.31078	34.80
58.6	1.28166	32.26	63.6	1.31139	34.85
58.7	1.28224	32.31	63.7	1.31199	34.90
58.8	1.28283	32.36	63.8	1.31260	34.96
58.9	1.28342	32.41	63.9	1.31320	35.01
59.0	1.28400	32.47	64.0	1.31381	35.06
59.1	1.28459	32.52	64.1	1.31442	35.11
59.2	1.28518	32.57	64.2	1.31502	35.16
59.3	1.28576	32.62	64.3	1.31563	35.21
59.4	1.28635	32.67	64.4	1.31624	35.27
59.5	1.28694	32.73	64.5	1.31684	35.32
59.6	1.28753	32.78	64.6	1.31745	35.37
59.7	1.28812	32.83	64.7	1.31806	35.42
59.8	1.28871	32.88	64.8	1.31867	35.47
59.9	1.28930	32.93	64.9	1.31928	35.52
60.0	1.28989	32.99	65.0	1.31989	35.57
60.1	1.29048	33.04	65.1	1.32050	35.63
60.2	1.29107	33.09	65.2	1.32111	35.68
60.3	1.29166	33.14	65.3	1.32172	35.73
60.4	1.29225	33.20	65.4	1.32233	35.78
60.5	1.29284	33.25	65.5	1.32294	35.83
60.6	1.29343	33.30	65.6	1.32355	35.88
60.7	1.29403	33.35	65.7	1.32417	35.93
60.8	1.29462	33.40	65.8	1.32478	35.98
60.9	1.29521	33.46	65.9	1.32539	36.04
61.0	1.29581	33.51	66.0	1.32601	36.09
61.1	1.29640	33.56	66.1	1.32662	36.14
61.2	1.29700	33.61	66.2	1.32724	36.19
61.3	1.29759	33.66	66.3	1.32785	36.24
61.4	1.29819	33.71	66.4	1.32847	36.29
61.5	1.29878	33.77	66.5	1.32908	36.34
61.6	1.29938	33.82	66.6	1.32970	36.39
61.7	1.29998	33.87	66.7	1.33031	36.45
61.8	1.30057	33.92	66.8	1.33093	36.50
61.9	1.30117	33.97	66.9	1.33155	36.55
62.0	1.30177	34.03	67.0	1.33217	36.60
62.1	1.30237	34.08	67.1	1.33278	36.65
62.2	1.30297	34.13	67.2	1.33340	36.70
62.3	1.30356	34.18	67.3	1.33402	36.75
62.4	1.30416	34.23	67.4	1.33464	36.80
62.5	1.30476	34.28	67.5	1.33526	36.85
62.6	1.30536	34.34	67.6	1.33588	36.90
62.7	1.30596	34.39	67.7	1.33650	36.96
62.8	1.30656	34.44	67.8	1.33712	37.01
62.9	1.30717	34.49	67.9	1.33774	37.06

DEGREES BAUMÉ	SPECIFIC GRAVITY (<i>d</i> 17.5 17.5)	DEGREES BAUMÉ	DEGREES BAUMÉ	SPECIFIC GRAVITY (<i>d</i> 17.5 17.5)	DEGREES BAUMÉ
68.0	1.33836	37.11	73.0	1.36995	39.64
68.1	1.33869	37.10	73.1	1.37059	39.69
68.2	1.33901	37.21	73.2	1.37124	39.74
68.3	1.34023	37.26	73.3	1.37188	39.79
68.4	1.34085	37.31	73.4	1.37252	39.84
68.5	1.34148	37.36	73.5	1.37317	39.89
68.6	1.34210	37.41	73.6	1.37381	39.94
68.7	1.34273	37.47	73.7	1.37446	39.99
68.8	1.34335	37.52	73.8	1.37510	40.04
68.9	1.34398	37.57	73.9	1.37575	40.09
69.0	1.34460	37.62	74.0	1.37639	40.14
69.1	1.34523	37.67	74.1	1.37704	40.19
69.2	1.34585	37.72	74.2	1.37768	40.24
69.3	1.34648	37.77	74.3	1.37833	40.29
69.4	1.34711	37.82	74.4	1.37898	40.34
69.5	1.34774	37.87	74.5	1.37962	40.39
69.6	1.34836	37.92	74.6	1.38027	40.44
69.7	1.34899	37.97	74.7	1.38092	40.49
69.8	1.34962	38.02	74.8	1.38157	40.54
69.9	1.35025	38.07	74.9	1.38222	40.59
70.0	1.35088	38.12	75.0	1.38287	40.64
70.1	1.35151	38.18	75.1	1.38352	40.69
70.2	1.35214	38.23	75.2	1.38417	40.74
70.3	1.35277	38.28	75.3	1.38482	40.79
70.4	1.35340	38.33	75.4	1.38547	40.84
70.5	1.35403	38.38	75.5	1.38612	40.89
70.6	1.35466	38.43	75.6	1.38677	40.94
70.7	1.35530	38.48	75.7	1.38743	40.99
70.8	1.35593	38.53	75.8	1.38808	41.04
70.9	1.35656	38.58	75.9	1.38873	41.09
71.0	1.35720	38.63	76.0	1.38939	41.14
71.1	1.35783	38.68	76.1	1.39004	41.19
71.2	1.35847	38.73	76.2	1.39070	41.24
71.3	1.35910	38.78	76.3	1.39135	41.29
71.4	1.35974	38.83	76.4	1.39201	41.33
71.5	1.36037	38.88	76.5	1.39266	41.38
71.6	1.36101	38.93	76.6	1.39332	41.43
71.7	1.36164	38.98	76.7	1.39397	41.48
71.8	1.36228	39.03	76.8	1.39463	41.53
71.9	1.36292	39.08	76.9	1.39529	41.58
72.0	1.36355	39.13	77.0	1.39595	41.63
72.1	1.36419	39.19	77.1	1.39660	41.68
72.2	1.36483	39.24	77.2	1.39726	41.73
72.3	1.36547	39.29	77.3	1.39792	41.78
72.4	1.36611	39.34	77.4	1.39858	41.83
72.5	1.36675	39.39	77.5	1.39924	41.88
72.6	1.36739	39.44	77.6	1.39990	41.93
72.7	1.36803	39.49	77.7	1.40056	41.98
72.8	1.36867	39.54	77.8	1.40122	42.03
72.9	1.36931	39.59	77.9	1.40188	42.08

TABLES

Pyramids Height	Surface Gravity (g)	Pyramids Density	Pyramids Index	Specific Gravity (d 15.5)	Pyramids Height
79.0	1.42471	42.13	83.0	1.43614	44.58
79.1	1.42481	42.16	83.1	1.43682	44.62
79.2	1.42491	42.23	83.2	1.43750	44.67
79.3	1.42504	42.28	83.3	1.43819	44.72
79.4	1.42518	42.32	83.4	1.43887	44.77
79.5	1.42532	42.37	83.5	1.43955	44.82
79.6	1.42547	42.42	83.6	1.44024	44.87
79.7	1.42562	42.47	83.7	1.44092	44.91
79.8	1.42577	42.52	83.8	1.44161	44.96
79.9	1.42592	42.57	83.9	1.44229	45.01
80.0	1.42608	42.62	84.0	1.44298	45.06
80.1	1.42623	42.67	84.1	1.44367	45.11
80.2	1.42638	42.72	84.2	1.44435	45.16
80.3	1.42654	42.77	84.3	1.44504	45.21
80.4	1.42670	42.82	84.4	1.44572	45.25
80.5	1.42686	42.87	84.5	1.44641	45.30
80.6	1.42702	42.92	84.6	1.44710	45.35
80.7	1.42718	42.97	84.7	1.44779	45.40
80.8	1.42734	43.01	84.8	1.44848	45.45
80.9	1.42750	43.06	84.9	1.44917	45.49
81.0	1.42766	43.11	85.0	1.44986	45.54
81.1	1.42782	43.16	85.1	1.45055	45.59
81.2	1.42798	43.21	85.2	1.45124	45.64
81.3	1.42814	43.26	85.3	1.45193	45.69
81.4	1.42830	43.31	85.4	1.45262	45.74
81.5	1.42846	43.36	85.5	1.45331	45.78
81.6	1.42862	43.41	85.6	1.45401	45.83
81.7	1.42878	43.45	85.7	1.45470	45.88
81.8	1.42894	43.50	85.8	1.45539	45.93
81.9	1.42910	43.55	85.9	1.45609	45.98
82.0	1.42926	43.60	86.0	1.45678	46.02
82.1	1.42942	43.65	86.1	1.45748	46.07
82.2	1.42958	43.70	86.2	1.45817	46.12
82.3	1.42974	43.75	86.3	1.45887	46.17
82.4	1.42990	43.80	86.4	1.45956	46.22
82.5	1.43006	43.85	86.5	1.46026	46.26
82.6	1.43022	43.90	86.6	1.46095	46.31
82.7	1.43038	43.94	86.7	1.46165	46.36
82.8	1.43054	43.99	86.8	1.46235	46.41
82.9	1.43070	44.04	86.9	1.46304	46.46
83.0	1.43086	44.09	87.0	1.46374	46.50
83.1	1.43102	44.14	87.1	1.46444	46.55
83.2	1.43118	44.19	87.2	1.46514	46.60
83.3	1.43134	44.24	87.3	1.46584	46.65
83.4	1.43150	44.28	87.4	1.46654	46.69
83.5	1.43166	44.33	87.5	1.46724	46.74
83.6	1.43182	44.38	87.6	1.46794	46.79
83.7	1.43198	44.43	87.7	1.46864	46.84
83.8	1.43214	44.48	87.8	1.46934	46.88
83.9	1.43230	44.53	87.9	1.47004	46.93

DEGREES BRIX	SPECIFIC GRAVITY ($d_{17.5}^{17.5}$)	DEGREES BAUMÉ	DEGREES BRIX	SPECIFIC GRAVITY ($d_{17.5}^{17.5}$)	DEGREES BAUMÉ
88.0	1.47074	46.98	93.0	1.50635	49.34
88.1	1.47145	47.03	93.1	1.50707	49.39
88.2	1.47215	47.08	93.2	1.50779	49.43
88.3	1.47285	47.12	93.3	1.50852	49.48
88.4	1.47356	47.17	93.4	1.50924	49.53
88.5	1.47426	47.22	93.5	1.50996	49.57
88.6	1.47496	47.27	93.6	1.51069	49.62
88.7	1.47567	47.31	93.7	1.51141	49.67
88.8	1.47637	47.36	93.8	1.51214	49.71
88.9	1.47708	47.41	93.9	1.51286	49.76
89.0	1.47778	47.46	94.0	1.51359	49.81
89.1	1.47849	47.50	94.1	1.51431	49.85
89.2	1.47920	47.55	94.2	1.51504	49.90
89.3	1.47991	47.60	94.3	1.51577	49.94
89.4	1.48061	47.65	94.4	1.51649	49.99
89.5	1.48132	47.69	94.5	1.51722	50.04
89.6	1.48203	47.74	94.6	1.51795	50.08
89.7	1.48274	47.79	94.7	1.51868	50.13
89.8	1.48345	47.83	94.8	1.51941	50.18
89.9	1.48416	47.88	94.9	1.52014	50.22
90.0	1.48486	47.93	95.0	1.52087	50.27
90.1	1.48558	47.98	95.1	1.52159	50.32
90.2	1.48629	48.02	95.2	1.52232	50.36
90.3	1.48700	48.07	95.3	1.52304	50.41
90.4	1.48771	48.12	95.4	1.52376	50.45
90.5	1.48842	48.17	95.5	1.52449	50.50
90.6	1.48913	48.21	95.6	1.52521	50.55
90.7	1.48985	48.26	95.7	1.52593	50.59
90.8	1.49056	48.31	95.8	1.52665	50.64
90.9	1.49127	48.35	95.9	1.52738	50.69
91.0	1.49199	48.40	96.0	1.52810	50.73
91.1	1.49270	48.45	96.1	1.52884	50.78
91.2	1.49342	48.50	96.2	1.52958	50.82
91.3	1.49413	48.54	96.3	1.53032	50.87
91.4	1.49485	48.59	96.4	1.53106	50.92
91.5	1.49556	48.64	96.5	1.53180	50.96
91.6	1.49628	48.68	96.6	1.53254	51.01
91.7	1.49700	48.73	96.7	1.53328	51.05
91.8	1.49771	48.78	96.8	1.53402	51.10
91.9	1.49843	48.82	96.9	1.53476	51.15
92.0	1.49915	48.87	97.0	1.53550	51.19
92.1	1.49987	48.92	97.1	1.53624	51.24
92.2	1.50058	48.96	97.2	1.53698	51.28
92.3	1.50130	49.01	97.3	1.53772	51.33
92.4	1.50202	49.06	97.4	1.53846	51.38
92.5	1.50274	49.11	97.5	1.53920	51.42
92.6	1.50346	49.15	97.6	1.53994	51.47
92.7	1.50419	49.20	97.7	1.54068	51.51
92.8	1.50491	49.25	97.8	1.54142	51.56
92.9	1.50563	49.29	97.9	1.54216	51.60

DEGREES BRIX	SPECIFIC GRAVITY ($d_{17.5}^{17.5}$)	DEGREES BAUMÉ	DEGREES BRIX	SPECIFIC GRAVITY ($d_{17.5}^{17.5}$)	DEGREES BAUMÉ
98.0	1.54290	51.65	99.0	1.55040	52.11
98.1	1.54365	51.70	99.1	1.55115	52.15
98.2	1.54440	51.74	99.2	1.55189	52.20
98.3	1.54515	51.79	99.3	1.55264	52.24
98.4	1.54590	51.83	99.4	1.55338	52.29
98.5	1.54665	51.88	99.5	1.55413	52.33
98.6	1.54740	51.92	99.6	1.55487	52.38
98.7	1.54815	51.97	99.7	1.55562	52.42
98.8	1.54890	52.01	99.8	1.55636	52.47
98.9	1.54965	52.06	99.9	1.55711	52.51
			100.0	1.55785	52.56

2.—STAMMER'S TABLE OF TEMPERATURE CORRECTIONS FOR BRIX HYDROMETER READINGS¹ (For mercurial thermometer)

DEGREE CENTI- GRADE	DEGREE BRIX OF THE SOLUTION												
	0	5	10	15	20	25	30	35	40	50	60	70	75
	The degree read is to be <i>decreased</i> by —												
0	0.17	0.30	0.41	0.52	0.62	0.72	0.82	0.92	0.98	1.11	1.22	1.25	1.29
5	0.23	0.30	0.37	0.44	0.52	0.59	0.65	0.72	0.75	0.80	0.88	0.91	0.94
10	0.20	0.26	0.29	0.33	0.36	0.39	0.42	0.45	0.48	0.50	0.54	0.58	0.61
11	0.18	0.23	0.26	0.28	0.31	0.34	0.36	0.39	0.41	0.43	0.47	0.50	0.53
12	0.16	0.20	0.22	0.24	0.26	0.29	0.31	0.33	0.34	0.36	0.40	0.42	0.46
13	0.14	0.18	0.19	0.21	0.22	0.24	0.26	0.27	0.28	0.29	0.33	0.35	0.39
14	0.12	0.15	0.16	0.17	0.18	0.19	0.21	0.22	0.22	0.23	0.26	0.28	0.32
15	0.09	0.11	0.12	0.14	0.14	0.15	0.16	0.17	0.16	0.17	0.19	0.21	0.25
16	0.06	0.07	0.08	0.09	0.10	0.10	0.11	0.12	0.12	0.12	0.14	0.16	0.18
17	0.02	0.02	0.03	0.03	0.03	0.04	0.04	0.04	0.04	0.04	0.05	0.05	0.06
	The degree read is to be <i>increased</i> by —												
18	0.02	0.03	0.03	0.03	0.03	0.03	0.03	0.03	0.03	0.03	0.03	0.03	0.02
19	0.06	0.08	0.08	0.09	0.09	0.10	0.10	0.10	0.10	0.10	0.10	0.08	0.06
20	0.11	0.14	0.15	0.17	0.17	0.18	0.18	0.18	0.19	0.19	0.18	0.15	0.11
21	0.16	0.20	0.22	0.24	0.24	0.25	0.25	0.25	0.26	0.26	0.25	0.22	0.18
22	0.21	0.26	0.29	0.31	0.31	0.32	0.32	0.32	0.33	0.34	0.32	0.29	0.25
23	0.27	0.32	0.35	0.37	0.38	0.39	0.39	0.39	0.40	0.42	0.39	0.36	0.33
24	0.32	0.38	0.41	0.43	0.44	0.46	0.46	0.47	0.47	0.50	0.46	0.43	0.40
25	0.37	0.44	0.47	0.49	0.51	0.53	0.54	0.55	0.55	0.58	0.54	0.51	0.48
26	0.43	0.50	0.54	0.56	0.58	0.60	0.61	0.62	0.62	0.66	0.62	0.58	0.55
27	0.49	0.57	0.61	0.63	0.65	0.68	0.68	0.69	0.70	0.74	0.70	0.65	0.62
28	0.55	0.64	0.68	0.70	0.72	0.76	0.76	0.78	0.78	0.82	0.78	0.72	0.70
29	0.63	0.71	0.75	0.78	0.79	0.84	0.84	0.86	0.86	0.90	0.86	0.80	0.78
30	0.70	0.78	0.82	0.87	0.87	0.92	0.92	0.94	0.94	0.98	0.94	0.88	0.86
35	1.10	1.17	1.22	1.24	1.30	1.32	1.33	1.35	1.36	1.39	1.34	1.27	1.25
40	1.50	1.61	1.67	1.71	1.73	1.79	1.79	1.80	1.82	1.83	1.78	1.69	1.65
50		2.65	2.71	2.74	2.78	2.80	2.80	2.80	2.80	2.79	2.70	2.56	2.51
60		3.87	3.88	3.88	3.88	3.88	3.88	3.88	3.90	3.82	3.70	3.43	3.41
70			5.18	5.20	5.14	5.13	5.10	5.08	5.06	4.90	4.72	4.47	4.35
80			6.62	6.59	6.54	6.46	6.38	6.30	6.26	6.06	5.82	5.50	5.33

¹ Note that these corrections take into consideration that the glass of the hydrometer as well as the sugar solution itself is affected by the temperature change.

BRIX READING FROM 0.5 TO 12.0		SACCHARIMETRIC DIVISIONS	BRIX READING AND								
Tenths of a Division	Per cent Sucrose		10.5	11.0	11.5	12.0	12.5	13.0	13.5	14.0	14.5
			1.0422	1.0443	1.0464	1.0485	1.0506	1.0528	1.0549	1.0570	1.0592
0.1	0.03	1	0.28	0.27	0.27	0.27	0.27	0.27	0.27	0.27	0.27
0.2	0.06	2	0.55	0.55	0.55	0.55	0.54	0.54	0.54	0.54	0.54
0.3	0.08	3	0.82	0.82	0.82	0.82	0.82	0.81	0.81	0.81	0.81
0.4	0.11	4	1.10	1.10	1.09	1.09	1.09	1.09	1.08	1.08	1.08
0.5	0.14	5	1.37	1.37	1.36	1.36	1.36	1.35	1.35	1.35	1.35
0.6	0.17	6	1.64	1.64	1.64	1.64	1.63	1.63	1.62	1.62	1.62
0.7	0.19	7	1.92	1.91	1.91	1.91	1.90	1.90	1.89	1.89	1.89
0.8	0.22	8	2.19	2.19	2.18	2.18	2.18	2.17	2.17	2.16	2.16
0.9	0.25	9	2.47	2.46	2.46	2.45	2.45	2.44	2.44	2.43	2.43
		10	2.74	2.74	2.73	2.73	2.72	2.71	2.71	2.70	2.70
		11	3.02	3.01	3.00	3.00	2.99	2.99	2.98	2.97	2.97
		12	3.29	3.28	3.28	3.27	3.26	3.26	3.25	3.24	3.24
		13	3.56	3.56	3.55	3.54	3.54	3.53	3.52	3.51	3.51
		14	3.84	3.83	3.82	3.82	3.81	3.80	3.79	3.78	3.78
		15	4.11	4.11	4.10	4.09	4.08	4.07	4.06	4.06	4.05
		16	4.39	4.38	4.37	4.36	4.35	4.34	4.33	4.33	4.32
		17	4.66	4.65	4.64	4.63	4.62	4.61	4.60	4.59	4.59
		18	4.93	4.93	4.91	4.91	4.90	4.89	4.88	4.87	4.86
		19	5.21	5.20	5.19	5.18	5.17	5.16	5.15	5.14	5.13
		20	5.49	5.47	5.46	5.45	5.44	5.43	5.42	5.41	5.40
0.1	0.03	21	5.76	5.75	5.74	5.73	5.71	5.70	5.69	5.68	5.67
0.2	0.05	22	6.03	6.02	6.01	6.00	5.99	5.97	5.96	5.95	5.94
0.3	0.08	23	6.31	6.30	6.28	6.27	6.26	6.24	6.23	6.22	6.21
0.4	0.11	24	6.58	6.57	6.56	6.54	6.53	6.52	6.50	6.49	6.48
0.5	0.13	25	6.86	6.84	6.83	6.82	6.80	6.79	6.78	6.76	6.75
0.6	0.16	26	7.13	7.12	7.10	7.09	7.07	7.06	7.05	7.03	7.02
0.7	0.19	27	7.41	7.39	7.38	7.36	7.35	7.33	7.32	7.30	7.29
0.8	0.21	28	7.68	7.66	7.65	7.63	7.62	7.60	7.59	7.57	7.56
0.9	0.24	29	7.96	7.94	7.92	7.91	7.89	7.87	7.86	7.84	7.83
		30	8.23	8.21	8.20	8.18	8.16	8.15	8.13	8.11	8.10
		31	8.50	8.49	8.47	8.45	8.44	8.42	8.40	8.39	8.37
		32	8.78	8.76	8.74	8.73	8.71	8.69	8.67	8.66	8.64
		33	9.05	9.03	9.02	9.00	8.98	8.96	8.94	8.93	8.91
		34	9.33	9.31	9.29	9.27	9.25	9.23	9.22	9.20	9.18
		35	9.60	9.58	9.56	9.54	9.53	9.51	9.49	9.47	9.45
		36	9.88	9.86	9.84	9.82	9.80	9.78	9.76	9.74	9.72
		37	10.15	10.13	10.11	10.09	10.07	10.05	10.03	10.01	9.99
		38	10.40	10.38	10.36	10.36	10.34	10.32	10.30	10.28	10.26
		39	10.68	10.66	10.64	10.64	10.61	10.59	10.57	10.55	10.53

UNION: SPECIFIC GRAVITY										SACCHARI- METRIC DIVISIONS
5.5	16.0	16.5	17.0	17.5	18.0	18.5	19.0	19.5	20.0	
0.635	1.0657	1.0678	1.0700	1.0722	1.0744	1.0766	1.0788	1.0811	1.0833	
0.27	0.27	0.27	0.27	0.27	0.27	0.27	0.27	0.27	0.26	1
0.54	0.54	0.54	0.53	0.53	0.53	0.53	0.53	0.53	0.53	2
0.81	0.80	0.80	0.80	0.80	0.80	0.80	0.79	0.79	0.79	3
1.08	1.07	1.07	1.07	1.07	1.06	1.06	1.06	1.06	1.06	4
1.34	1.34	1.34	1.34	1.33	1.33	1.33	1.32	1.32	1.32	5
1.61	1.61	1.61	1.60	1.60	1.60	1.59	1.59	1.59	1.58	6
1.88	1.88	1.87	1.87	1.86	1.86	1.86	1.85	1.85	1.85	7
2.15	2.15	2.14	2.14	2.13	2.13	2.12	2.12	2.12	2.11	8
2.42	2.41	2.41	2.40	2.40	2.39	2.39	2.38	2.38	2.37	9
2.69	2.68	2.68	2.67	2.67	2.66	2.65	2.65	2.64	2.64	10
2.95	2.95	2.94	2.94	2.93	2.92	2.92	2.91	2.91	2.90	11
3.22	3.22	3.21	3.20	3.20	3.19	3.18	3.18	3.17	3.17	12
3.49	3.49	3.48	3.47	3.46	3.46	3.45	3.44	3.44	3.43	13
3.76	3.75	3.75	3.74	3.73	3.72	3.72	3.71	3.70	3.69	14
4.03	4.02	4.02	4.01	4.00	3.99	3.98	3.97	3.97	3.96	15
4.30	4.29	4.28	4.27	4.26	4.26	4.25	4.24	4.23	4.22	16
4.57	4.56	4.55	4.54	4.53	4.52	4.51	4.50	4.49	4.48	17
4.84	4.83	4.82	4.81	4.80	4.79	4.78	4.77	4.76	4.75	18
5.11	5.10	5.09	5.08	5.06	5.05	5.04	5.03	5.02	5.01	19
5.38	5.36	5.35	5.34	5.33	5.32	5.31	5.30	5.29	5.28	20
5.65	5.63	5.62	5.61	5.60	5.59	5.58	5.56	5.55	5.54	21
5.91	5.90	5.89	5.88	5.87	5.85	5.84	5.83	5.82	5.80	22
6.18	6.17	6.16	6.14	6.13	6.12	6.11	6.09	6.08	6.07	23
6.45	6.44	6.43	6.41	6.40	6.39	6.37	6.36	6.35	6.33	24
6.72	6.71	6.69	6.68	6.67	6.65	6.64	6.63	6.61	6.60	25
6.99	6.97	6.96	6.95	6.93	6.92	6.90	6.89	6.88	6.86	26
7.26	7.24	7.23	7.21	7.20	7.18	7.17	7.15	7.14	7.13	27
7.53	7.51	7.50	7.48	7.47	7.45	7.44	7.42	7.40	7.39	28
7.80	7.78	7.77	7.75	7.73	7.72	7.70	7.68	7.67	7.65	29
8.06	8.05	8.03	8.02	8.00	7.98	7.97	7.95	7.93	7.92	30
8.33	8.32	8.30	8.28	8.27	8.25	8.23	8.21	8.20	8.18	31
8.60	8.58	8.57	8.55	8.53	8.51	8.50	8.48	8.46	8.45	32
8.87	8.85	8.84	8.82	8.80	8.78	8.76	8.75	8.73	8.71	33
9.14	9.12	9.10	9.09	9.07	9.05	9.03	9.01	8.99	8.97	34
9.41	9.39	9.37	9.35	9.34	9.31	9.30	9.28	9.26	9.24	35
9.68	9.66	9.64	9.62	9.60	9.58	9.56	9.54	9.52	9.50	36
9.95	9.93	9.91	9.89	9.87	9.85	9.83	9.81	9.79	9.77	37
10.22	10.20	10.18	10.15	10.13	10.11	10.09	10.07	10.05	10.03	38
10.49	10.46	10.44	10.42	10.40	10.38	10.36	10.34	10.32	10.29	39

BRIX READING FROM 11.5 TO 22.5		SACCHARI- METRIC DIVISIONS	BRIX READING AND					
Tenths of a Division	Per cent Sucrose		11.5 1.0464	12.0 1.0485	12.5 1.0506	13.0 1.0528	13.5 1.0549	14.0 1.0570
		40	10.93	10.91	10.89	10.86	10.84	10.82
0.1	0.03	41		11.18	11.16	11.14	11.12	11.09
0.2	0.05	42		11.46	11.43	11.41	11.39	11.36
0.3	0.08	43			11.71	11.68	11.66	11.64
0.4	0.11	44			11.98	11.95	11.93	11.91
0.5	0.13	45			12.25	12.23	12.20	12.18
0.6	0.16	47				12.50	12.47	12.45
0.2	0.19	46					12.74	12.72
0.8	0.21	48					13.02	12.99
0.9	0.24	49						13.26
		50						
		51						
		52						
		53						
		54						
BRIX READING FROM 23.0 TO 24.0		55						
		56						
		57						
		58						
		59						
		60						
0.1	0.03	61						
0.2	0.05	62						
0.3	0.08	63						
0.4	0.10	64						
0.5	0.13	65						
0.6	0.16	66						
0.7	0.18	67						
0.8	0.21	68						
0.9	0.23	69						
		70						
		71						
		72						
		73						
		74						
		75						
		76						
		77						
		78						
		79						
		80						

BRIX READING FROM 11.5 TO 22.5		SACCHARI- METRIC DIVISIONS	BRIX READING AND					
Tenths of a Division	Per cent Sucrose		18.0 1.0744	18.5 1.0766	19.0 1.0788	19.5 1.0811	20.0 1.0833	20.5 1.0855
0.1	0.03	40	10.64	10.62	10.60	10.58	10.56	10.54
0.2	0.05	41	10.91	10.89	10.87	10.85	10.82	10.80
0.3	0.08	42	11.18	11.16	11.13	11.11	11.09	11.07
0.4	0.11	43	11.45	11.42	11.40	11.38	11.35	11.33
		44	11.71	11.69	11.66	11.64	11.62	11.59
0.5	0.13	45	11.98	11.96	11.93	11.91	11.88	11.86
0.6	0.16	46	12.25	12.22	12.20	12.17	12.15	12.12
0.7	0.19	47	12.51	12.49	12.46	12.44	12.41	12.39
0.8	0.21	48	12.78	12.75	12.73	12.70	12.67	12.65
0.9	0.24	49	13.05	13.02	12.99	12.97	12.94	12.91
			50	13.31	13.29	13.26	13.23	13.20
			51	13.58	13.55	13.52	13.50	13.47
			52	13.85	13.82	13.79	13.76	13.73
			53	14.11	14.08	14.05	14.03	14.00
			54	14.38	14.35	14.32	14.29	14.26
			55	14.65	14.62	14.59	14.56	14.53
			56	14.91	14.88	14.85	14.82	14.79
			57	15.18	15.15	15.12	15.09	15.06
			58	15.45	15.42	15.38	15.35	15.32
			59	15.71	15.68	15.65	15.62	15.58
			60	15.98	15.95	15.92	15.88	15.85
0.1	0.03	61	16.25	16.21	16.18	16.15	16.11	16.08
0.2	0.05	62	16.52	16.48	16.45	16.41	16.38	16.35
0.3	0.08	63	16.78	16.75	16.71	16.68	16.64	16.61
0.4	0.10	64	17.05	17.01	16.98	16.94	16.91	16.87
0.5	0.13	65	17.32	17.28	17.24	17.21	17.17	17.14
0.6	0.16	66		17.55	17.51	17.47	17.44	17.40
0.7	0.18	67		17.81	17.78	17.74	17.70	17.67
0.8	0.21	68			18.04	18.00	17.97	17.93
0.9	0.23	69			18.31	18.27	18.23	18.19
			70			18.53	18.50	18.46
			71				18.76	18.72
			72				19.03	18.99
			73					19.25
			74					19.52
			75					19.78
			76					
			77					
			78					
			79					
			80					

CORRESPONDING SPECIFIC GRAVITY							SACCHARI-METRIC DIVISIONS
21.0 1.0878	21.5 1.0900	22.0 1.0923	22.5 1.0946	23.0 1.0969	23.5 1.0992	24.0 1.1015	
10.52	10.49	10.47	10.45	10.43	10.41	10.38	40
10.78	10.76	10.74	10.71	10.69	10.67	10.65	41
11.04	11.02	11.00	10.97	10.95	10.93	10.90	42
11.31	11.28	11.26	11.24	11.21	11.19	11.17	43
11.57	11.55	11.52	11.50	11.47	11.45	11.42	44
11.83	11.81	11.78	11.76	11.73	11.71	11.69	45
12.09	12.07	12.05	12.02	12.00	11.97	11.94	46
12.36	12.33	12.31	12.28	12.26	12.23	12.21	47
12.62	12.60	12.57	12.54	12.52	12.49	12.47	48
12.88	12.86	12.83	12.81	12.78	12.75	12.73	49
13.15	13.12	13.09	13.07	13.04	13.01	12.99	50
13.41	13.39	13.36	13.33	13.30	13.27	13.25	51
13.68	13.65	13.62	13.59	13.56	13.53	13.51	52
13.94	13.91	13.88	13.85	13.82	13.79	13.77	53
14.20	14.17	14.14	14.11	14.08	14.06	14.02	54
14.47	14.44	14.41	14.38	14.35	14.32	14.29	55
14.73	14.70	14.67	14.64	14.61	14.58	14.55	56
14.99	14.96	14.93	14.90	14.87	14.84	14.81	57
15.26	15.23	15.19	15.16	15.13	15.10	15.07	58
15.52	15.49	15.46	15.42	15.39	15.36	15.33	59
15.78	15.75	15.72	15.69	15.65	15.62	15.59	60
16.05	16.01	15.98	15.95	15.91	15.88	15.85	61
16.31	16.28	16.24	16.21	16.18	16.14	16.11	62
16.57	16.54	16.51	16.47	16.44	16.40	16.37	63
16.84	16.80	16.77	16.73	16.70	16.66	16.63	64
17.10	17.07	17.03	17.00	16.96	16.92	16.89	65
17.37	17.33	17.29	17.26	17.22	17.19	17.15	66
17.63	17.59	17.56	17.52	17.48	17.45	17.41	67
17.89	17.86	17.82	17.78	17.74	17.71	17.67	68
18.16	18.12	18.08	18.04	18.00	17.97	17.93	69
18.42	18.38	18.35	18.31	18.27	18.23	18.19	70
18.68	18.65	18.61	18.57	18.53	18.49	18.45	71
18.95	18.91	18.87	18.83	18.79	18.75	18.71	72
19.21	19.17	19.13	19.09	19.05	19.01	18.97	73
19.48	19.44	19.40	19.35	19.31	19.27	19.23	74
19.74	19.70	19.66	19.62	19.57	19.53	19.49	75
20.00	19.96	19.92	19.88	19.84	19.80	19.75	76
20.27	20.22	20.18	20.14	20.10	20.06	20.01	77
	20.49	20.45	20.40	20.36	20.32	20.27	78
	20.75	20.71	20.66	20.62	20.58	20.54	79
		20.97	20.93	20.88	20.84	20.80	80

4.—EQUIVALENTS OF DEXTROSE, MALTOSE, AND LACTOSE
IN PARTS OF COPPER OXIDE OBTAINED BY DEFREN'S
METHOD OF DETERMINATION

PARTS COPPER OXIDE	PARTS DEXTROSE	PARTS MALTOSE	PARTS LACTOSE	PARTS COPPER OXIDE	PARTS DEXTROSE	PARTS MALTOSE	PARTS LACTOSE
30	13.2	21.7	18.8	77	34.0	56.0	48.5
31	13.7	22.4	19.5	78	34.4	56.7	49.2
32	14.1	23.1	20.1	79	34.9	57.4	49.8
33	14.6	23.9	20.7	80	35.4	58.1	50.5
34	15.0	24.6	21.4	81	35.9	58.9	51.1
35	15.4	25.3	22.0	82	36.3	59.6	51.7
36	15.9	26.1	22.6	83	36.8	60.3	52.4
37	16.3	26.8	23.3	84	37.2	61.1	53.0
38	16.8	27.5	23.9	85	37.7	61.8	53.6
39	17.2	28.3	24.5	86	38.1	62.5	54.3
40	17.6	29.0	25.2	87	38.5	63.3	54.9
41	18.1	29.7	25.8	88	39.0	64.0	55.5
42	18.5	30.5	26.4	89	39.4	64.7	56.2
43	19.0	31.2	27.1	90	39.9	65.5	56.8
44	19.4	31.9	27.7	91	40.3	66.2	57.4
45	19.9	32.7	28.3	92	40.8	66.9	58.1
46	20.3	33.4	29.0	93	41.2	67.7	58.7
47	20.7	34.1	29.6	94	41.7	68.4	59.3
48	21.2	34.8	30.2	95	42.1	69.1	60.0
49	21.6	35.5	30.8	96	42.5	69.9	60.6
50	22.1	36.2	31.5	97	43.0	70.6	61.2
51	22.5	37.0	32.1	98	43.4	71.3	61.9
52	23.0	37.7	32.7	99	43.9	72.1	62.5
53	23.4	38.4	33.3	100	44.4	72.8	63.2
54	23.8	39.2	34.0	101	44.8	73.5	63.8
55	24.2	39.9	34.6	102	45.3	74.3	64.4
56	24.7	40.5	35.2	103	45.7	75.0	65.1
57	25.1	41.3	35.9	104	46.2	75.7	65.7
58	25.5	42.1	36.5	105	46.6	76.5	66.3
59	26.0	42.8	37.1	106	47.0	77.2	67.0
60	26.4	43.5	37.8	107	47.5	77.9	67.6
61	26.9	44.3	38.4	108	48.0	78.7	68.2
62	27.3	45.0	39.0	109	48.4	79.4	68.9
63	27.8	45.7	39.7	110	48.9	80.1	69.5
64	28.2	46.5	40.3	111	49.3	80.9	70.1
65	28.7	47.2	40.9	112	49.8	81.6	70.8
66	29.1	47.9	41.6	113	50.2	82.3	71.4
67	29.5	48.6	42.2	114	50.7	83.1	72.0
68	30.0	49.4	42.8	115	51.1	83.8	72.7
69	30.4	50.1	43.5	116	51.6	84.5	73.3
70	30.9	50.8	44.1	117	52.0	85.2	74.0
71	31.3	51.6	44.7	118	52.4	85.9	74.6
72	31.8	52.3	45.4	119	52.9	86.6	75.2
73	32.2	53.0	46.0	120	53.3	87.4	75.9
74	32.6	53.8	46.6	121	53.8	88.1	76.6
75	33.1	54.5	47.3	122	54.2	88.9	77.2
76	33.5	55.2	47.9	123	54.7	89.6	77.9

PARTS COPPER OXIDE	PARTS DEXTROSE	PARTS MALTOSE	PARTS LACTOSE	PARTS COPPER OXIDE	PARTS DEXTROSE	PARTS MALTOSE	PARTS LACTOSE
124	55.1	90.3	78.5	178	79.5	130.3	113.3
125	55.6	91.1	79.1	179	80.0	131.0	113.9
126	56.0	91.8	79.8	180	80.4	131.8	114.6
127	56.5	92.5	80.4	181	80.8	132.5	115.2
128	56.9	93.3	81.1	182	81.3	133.2	115.8
129	57.3	94.0	81.7	183	81.8	134.0	116.5
130	57.8	94.8	82.4	184	82.2	134.7	117.1
131	58.2	95.5	83.0	185	82.7	135.5	117.8
132	58.7	96.2	83.6	186	83.1	136.2	118.4
133	59.1	97.0	84.2	187	83.5	136.9	119.1
134	59.6	97.7	84.9	188	84.0	137.7	119.7
135	60.0	98.4	85.5	189	84.4	138.4	120.4
136	60.5	99.2	86.1	190	84.9	139.1	121.0
137	60.9	99.9	86.8	191	85.4	139.9	121.7
138	61.3	100.7	87.4	192	85.9	140.6	122.3
139	61.8	101.4	88.1	193	86.3	141.4	123.0
140	62.2	102.1	88.7	194	86.8	142.1	123.6
141	62.7	102.8	89.3	195	87.2	142.8	124.3
142	63.1	103.5	90.0	196	87.7	143.6	124.9
143	63.6	104.3	90.6	197	88.1	144.3	125.6
144	64.0	105.0	91.3	198	88.6	145.1	126.2
145	64.5	105.8	91.9	199	89.0	145.8	126.9
146	64.9	106.5	92.6	200	89.5	146.6	127.5
147	65.4	107.2	93.2	201	89.9	147.3	128.2
148	65.8	108.0	93.9	202	90.4	148.1	128.8
149	66.3	108.7	94.5	203	90.8	148.8	129.5
150	66.8	109.5	95.2	204	91.3	149.6	130.1
151	67.3	110.2	95.8	205	91.7	150.3	130.8
152	67.7	111.0	96.5	206	92.2	151.1	131.5
153	68.3	111.7	97.1	207	92.6	151.8	132.1
154	68.7	112.4	97.8	208	93.1	152.5	132.8
155	69.2	113.2	98.4	209	93.5	153.3	133.4
156	69.6	113.9	99.1	210	94.0	154.1	134.1
157	70.0	114.7	99.7	211	94.4	154.8	134.7
158	70.5	115.4	100.4	212	94.9	155.6	135.4
159	70.9	116.1	101.0	213	95.3	156.3	136.0
160	71.3	116.9	101.7	214	95.8	157.1	136.7
161	71.8	117.6	102.3	215	96.3	157.8	137.3
162	72.3	118.4	103.0	216	96.7	158.6	138.0
163	72.7	119.1	103.6	217	97.2	159.3	138.6
164	73.2	119.9	104.3	218	97.6	160.0	139.3
165	73.6	120.6	104.9	219	98.1	160.8	139.9
166	74.1	121.4	105.6	220	98.6	161.5	140.6
167	74.5	122.1	106.2	221	99.0	162.3	141.2
168	74.9	122.9	106.9	222	99.5	163.0	141.9
169	75.4	123.6	107.5	223	99.9	163.7	142.5
170	75.8	124.4	108.2	224	100.4	164.5	143.2
171	76.3	125.1	108.8	225	100.9	165.3	143.8
172	76.8	125.8	109.5	226	101.3	166.0	144.5
173	77.3	126.6	110.1	227	101.8	166.8	145.1
174	77.7	127.3	110.8	228	102.2	167.5	145.8
175	78.2	128.1	111.4	229	102.7	168.3	146.4
176	78.6	128.8	112.0	230	103.1	169.1	147.0
177	79.1	129.5	112.6	231	103.6	169.8	147.7

PARTS COPPER OXIDE	PARTS DEXTRORSE	PARTS MALTOSE	PARTS LACTOSE	PARTS COPPER OXIDE	PARTS DEXTRORSE	PARTS MALTOSE	PARTS LACTOSE
232	104.0	170.6	148.3	277	124.6	204.5	177.6
233	104.5	171.3	149.0	278	125.1	205.2	178.3
234	105.0	172.1	149.6	279	125.6	206.0	178.9
235	105.4	172.8	150.3	280	126.1	206.8	179.6
236	105.9	173.6	150.9	281	126.5	207.5	180.2
237	106.3	174.3	151.6	282	127.0	208.3	180.9
238	106.8	175.1	152.2	283	127.4	209.0	181.5
239	107.2	175.8	152.9	284	127.9	209.8	182.2
240	107.7	176.6	153.5	285	128.3	210.5	182.9
241	108.1	177.3	154.2	286	128.8	211.3	183.6
242	108.6	178.1	154.8	287	129.3	212.1	184.2
243	109.0	178.8	155.5	288	129.7	212.8	184.9
244	109.5	179.6	156.1	289	130.2	213.6	185.6
245	109.9	180.3	156.8	290	130.6	214.3	186.2
246	110.4	181.1	157.4	291	131.1	215.1	186.9
247	110.9	181.8	158.1	292	131.5	215.9	187.6
248	111.3	182.6	158.7	293	132.0	216.6	188.2
249	111.8	183.3	159.4	294	132.5	217.4	188.9
250	112.3	184.1	160.0	295	133.0	218.2	189.5
251	112.7	184.8	160.7	296	133.4	218.9	190.2
252	113.2	185.5	161.3	297	133.9	219.7	190.8
253	113.7	186.3	162.0	298	134.3	220.4	191.5
254	114.1	187.1	162.6	299	134.8	221.2	192.1
255	114.6	187.8	163.3	300	135.3	221.9	192.8
256	115.0	188.6	163.9	301	135.7	222.7	193.4
257	115.5	189.3	164.6	302	136.2	223.5	194.1
258	116.0	190.1	165.2	303	136.6	224.2	194.7
259	116.4	190.8	165.9	304	137.1	225.0	195.3
260	116.9	191.6	166.5	305	137.6	225.8	196.0
261	117.3	192.4	167.2	306	138.0	226.5	196.6
262	117.8	193.1	167.8	307	138.5	227.3	197.3
263	118.3	193.9	168.1	308	138.9	228.1	197.9
264	118.7	194.6	169.5	309	139.4	228.8	198.6
265	119.2	195.4	169.8	310	139.9	229.6	199.3
266	119.6	196.1	170.4	311	140.3	230.4	199.9
267	120.1	196.9	171.1	312	140.8	231.1	200.6
268	120.6	197.7	171.7	313	141.2	231.9	201.3
269	121.0	198.4	172.4	314	141.7	232.7	202.0
270	121.4	199.2	173.0	315	142.2	233.4	202.6
271	121.9	199.9	173.7	316	142.6	234.2	203.3
272	122.4	200.7	174.4	317	143.1	234.9	203.9
273	122.8	201.5	175.0	318	143.6	235.7	204.6
274	123.3	202.2	175.7	319	144.0	236.5	205.3
275	123.7	203.0	176.3	320	144.5	237.2	205.9
276	124.2	203.7	177.0				

5.—CALCULATED VALUES OF CUPRIC-REDUCING POWERS AND PARTS OF MALTOSE, DEXTROSE, AND DEXTRIN PER UNIT OF CARBOHYDRATE FOR EACH DEGREE OF ROTATION OF A NORMALLY ACID HYDROLYZED STARCH SOLUTION

$[\alpha]_{D 386}^{20}$	K_{386}^*	m_{386}	D_{386}	Δ_{386}
195	0.000	0.000	0.000	1.000
194	0.011	0.017	0.001	0.982
193	0.022	0.038	0.001	0.966
192	0.032	0.052	0.001	0.947
191	0.041	0.068	0.002	0.930
190	0.051	0.084	0.002	0.914
189	0.061	0.098	0.002	0.900
188	0.071	0.114	0.003	0.883
187	0.081	0.128	0.003	0.869
186	0.090	0.143	0.005	0.852
185	0.100	0.157	0.005	0.838
184	0.109	0.170	0.008	0.822
183	0.118	0.183	0.010	0.807
182	0.127	0.195	0.012	0.793
181	0.137	0.207	0.014	0.779
180	0.146	0.219	0.016	0.765
179	0.155	0.227	0.019	0.754
178	0.164	0.237	0.022	0.741
177	0.173	0.247	0.024	0.729
176	0.182	0.257	0.027	0.716
175	0.191	0.266	0.031	0.705
174	0.199	0.274	0.034	0.692
173	0.207	0.282	0.038	0.680
172	0.216	0.290	0.042	0.668
171	0.224	0.298	0.046	0.656
170	0.233	0.305	0.050	0.645
169	0.242	0.312	0.053	0.635
168	0.251	0.318	0.056	0.625
167	0.259	0.325	0.060	0.615
166	0.267	0.331	0.064	0.605
165	0.275	0.337	0.068	0.595
164	0.283	0.343	0.073	0.584
163	0.292	0.350	0.076	0.572
162	0.300	0.356	0.083	0.561
161	0.308	0.362	0.088	0.550
160	0.316	0.367	0.093	0.540
159	0.324	0.374	0.098	0.528
158	0.332	0.381	0.102	0.517
157	0.340	0.387	0.106	0.507
156	0.348	0.392	0.110	0.498
155	0.356	0.397	0.115	0.488
154	0.365	0.402	0.120	0.478
153	0.373	0.407	0.125	0.468

* Obtained by Defren's Reduction Method.

$[\alpha]_{D 386}^{20}$	κ_{386}	m_{386}	D_{386}	Δ_{386}
152	0.381	0.412	0.130	0.458
151	0.389	0.414	0.135	0.451
150	0.397	0.421	0.140	0.439
149	0.404	0.425	0.146	0.429
148	0.412	0.429	0.152	0.419
147	0.419	0.432	0.158	0.410
146	0.427	0.434	0.163	0.403
145	0.435	0.436	0.169	0.395
144	0.442	0.439	0.175	0.386
143	0.450	0.442	0.183	0.375
142	0.458	0.445	0.188	0.367
141	0.465	0.448	0.193	0.359
140	0.473	0.450	0.199	0.351
139	0.481	0.452	0.206	0.342
138	0.488	0.454	0.212	0.334
137	0.496	0.456	0.219	0.325
136	0.503	0.458	0.224	0.318
135	0.510	0.459	0.230	0.311
134	0.517	0.459	0.237	0.304
133	0.524	0.460	0.244	0.296
132	0.531	0.460	0.250	0.290
131	0.538	0.461	0.257	0.282
130	0.546	0.462	0.264	0.274
129	0.553	0.462	0.272	0.266
128	0.560	0.462	0.279	0.258
127	0.567	0.461	0.287	0.253
126	0.574	0.460	0.294	0.246
125	0.580	0.460	0.301	0.239
124	0.588	0.459	0.308	0.233
123	0.595	0.458	0.315	0.227
122	0.602	0.456	0.323	0.221
121	0.608	0.455	0.331	0.214
120	0.614	0.453	0.338	0.209
119	0.621	0.451	0.346	0.203
118	0.628	0.450	0.354	0.196
117	0.635	0.448	0.361	0.191
116	0.642	0.446	0.369	0.185
115	0.649	0.444	0.377	0.178
114	0.656	0.442	0.387	0.171
113	0.663	0.439	0.395	0.166
112	0.669	0.436	0.403	0.161
111	0.675	0.433	0.411	0.156
110	0.681	0.429	0.420	0.152
109	0.687	0.425	0.428	0.147
108	0.694	0.421	0.436	0.143
107	0.700	0.418	0.445	0.137
106	0.707	0.414	0.453	0.133
105	0.713	0.411	0.462	0.127
104	0.719	0.407	0.471	0.122
103	0.725	0.402	0.480	0.118
102	0.732	0.398	0.489	0.113
101	0.738	0.393	0.498	0.109
100	0.744	0.389	0.508	0.103
99	0.750	0.384	0.518	0.099

$[\alpha]_{D, 386}^{20}$	k_{386}	m_{386}	L_{386}	A_{386}
98	0.757	0.380	0.527	0.093
97	0.763	0.374	0.536	0.090
96	0.769	0.368	0.545	0.087
95	0.775	0.362	0.554	0.084
94	0.781	0.357	0.563	0.080
93	0.787	0.352	0.572	0.076
92	0.793	0.347	0.581	0.072
91	0.799	0.342	0.591	0.068
90	0.805	0.336	0.600	0.064
89	0.810	0.329	0.610	0.061
88	0.816	0.322	0.620	0.058
87	0.822	0.315	0.630	0.055
86	0.828	0.308	0.640	0.052
85	0.834	0.302	0.650	0.048
84	0.839	0.294	0.660	0.044
83	0.844	0.287	0.670	0.043
82	0.850	0.279	0.680	0.041
81	0.856	0.272	0.690	0.038
80	0.862	0.264	0.701	0.035
79	0.867	0.256	0.712	0.032
78	0.872	0.247	0.722	0.031
77	0.878	0.237	0.733	0.030
76	0.884	0.228	0.744	0.028
75	0.889	0.219	0.755	0.026
74	0.895	0.210	0.766	0.024
73	0.901	0.199	0.778	0.023
72	0.906	0.189	0.789	0.022
71	0.911	0.179	0.801	0.020
70	0.916	0.170	0.811	0.018
69	0.921	0.159	0.824	0.017
68	0.926	0.149	0.835	0.016
67	0.932	0.139	0.846	0.015
66	0.937	0.130	0.856	0.014
65	0.942	0.121	0.867	0.012
64	0.947	0.110	0.879	0.011
63	0.952	0.099	0.890	0.011
62	0.957	0.088	0.902	0.010
61	0.962	0.078	0.914	0.008
60	0.967	0.068	0.926	0.006
59	0.972	0.057	0.937	0.006
58	0.977	0.047	0.948	0.005
57	0.982	0.036	0.960	0.004
56	0.987	0.025	0.971	0.004
55	0.992	0.015	0.982	0.003
54	0.997	0.005	0.993	0.002
53	1.000	0.000	1.000	0.000

6. — DENSITY OF WATER AT DIFFERENT TEMPERATURES

TEMPERATURE: DEGREES CENTIGRADE	DENSITY OF WATER RELATIVE TO ITS DEN- SITY AT 4° C.	TEMPERATURE: DEGREES CENTIGRADE	DENSITY OF WATER RELATIVE TO ITS DEN- SITY AT 4° C.
0°	0.99987	27°	0.99660
1	0.99993	28	0.99633
2	0.99997	29	0.99605
3	0.99999	30	0.99577
4	1.00000	31	0.99547
5	0.99999	32	0.99517
6	0.99997	33	0.99485
7	0.99993	34	0.99452
8	0.99989	35	0.99418
9	0.99982	36	0.99383
10	0.99975	37	0.99347
11	0.99966	38	0.99310
12	0.99955	39	0.99273
13	0.99943	40	0.99235
14	0.99930	41	0.99197
15	0.99916	42	0.99158
15.5	0.99908	43	0.99118
16	0.99900	44	0.99078
17	0.99884	45	0.99037
17.5	0.99875	46	0.98996
18	0.99865	47	0.98954
19	0.99846	48	0.98910
20	0.99826	49	0.98865
21	0.99805	50	0.98819
22	0.99783	60	0.98334
23	0.99760	70	0.97790
24	0.99737	80	0.97191
25	0.99712	90	0.96550
26	0.99687	100	0.95863

The temperature readings are those given by a *mercury* thermometer. Landolt's table refers to *hydrogen* thermometer readings. The readings of the two thermometers agree at 0 and 100°. At 20° the mercury thermometer reads about 0.1° less than the hydrogen.

7.—VOLUMES OF SUGAR SOLUTIONS AT TEMPERATURES BETWEEN 0° AND 100° C. (*Mercury thermometer*)
(Volume at 0° = 1. Gerlach.)

TEMP. °C.	0 %	5 %	10 %	15 %	20 %	25 %	30 %	35 %
0	1.00000	1.00000	1.00000	1.00000	1.00000	1.00000	1.00000	1.00000
5	0.99989	1.00013	1.00028	1.00043	1.00053	1.00063	1.00083	1.00093
10	1.00013	1.00046	1.00076	1.00100	1.00130	1.00161	1.00186	1.00216
15	1.00070	1.00114	1.00159	1.00199	1.00239	1.00289	1.00319	1.00359
17.5	1.00110	1.00170	1.00210	1.00260	1.00305	1.00355	1.00405	1.00455
20	1.00160	1.00232	1.00271	1.00332	1.00382	1.00432	1.00482	1.00522
25	1.00275	1.00365	1.00415	1.00475	1.00535	1.00595	1.00650	1.00695
30	1.00415	1.00508	1.00568	1.00638	1.00698	1.00768	1.00823	1.00878
35	1.00575	1.00681	1.00741	1.00811	1.00881	1.00951	1.01011	1.01071
40	1.00755	1.00864	1.00934	1.01014	1.01084	1.01155	1.01220	1.01280
45	1.00955	1.01077	1.01153	1.01223	1.01308	1.01378	1.01443	1.01503
50	1.01175	1.01301	1.01381	1.01461	1.01541	1.01616	1.01676	1.01737
55	1.01415	1.01544	1.01624	1.01704	1.01785	1.01865	1.01925	1.01980
60	1.01675	1.01808	1.01878	1.01958	1.02038	1.02118	1.02160	1.02233
65	1.01955	1.02081	1.02141	1.02232	1.02302	1.02382	1.02447	1.02497
70	1.02255	1.02365	1.02425	1.02515	1.02575	1.02655	1.02721	1.02771
75	1.02570	1.02669	1.02719	1.02809	1.02869	1.02939	1.03004	1.03054
80	1.02900	1.02973	1.03033	1.03113	1.03183	1.03243	1.03303	1.03348
85	1.03240	1.03307	1.03367	1.03437	1.03517	1.03567	1.03617	1.03657
90	1.03585	1.03661	1.03721	1.03781	1.03861	1.03911	1.03951	1.03976
95	1.03930	1.04335	1.04085	1.04145	1.04215	1.04255	1.04286	1.04311
100	1.04275	1.04409	1.04459	1.04520	1.04570	1.04600	1.04630	1.04660

TEMP. °C.	40 %	45 %	50 %	55 %	60 %	65 %	70 %	75 %
0	1.00000	1.00000	1.00000	1.00000	1.00000	1.00000	1.00000	1.00000
5	1.00113	1.00133	1.00153	1.00163	1.00173	1.00173	1.00178	1.00183
10	1.00246	1.00276	1.00306	1.00326	1.00341	1.00351	1.00356	1.00366
15	1.00399	1.00434	1.00469	1.00494	1.00514	1.00529	1.00539	1.00549
17.5	1.00480	1.00515	1.00550	1.00581	1.00606	1.00616	1.00626	1.00641
20	1.00562	1.00602	1.00642	1.00667	1.00692	1.00712	1.00722	1.00732
25	1.00735	1.00785	1.00825	1.00850	1.00880	1.00895	1.00905	1.00920
30	1.00918	1.00978	1.01018	1.01043	1.01073	1.01098	1.01093	1.01113
35	1.01116	1.01182	1.01222	1.01247	1.01277	1.01302	1.01287	1.01312
40	1.01335	1.01395	1.01435	1.01460	1.01490	1.01515	1.01485	1.01515
45	1.01558	1.01623	1.01658	1.01683	1.01713	1.01728	1.01688	1.01728
50	1.01791	1.01862	1.01892	1.01917	1.01947	1.01952	1.01912	1.01952
55	1.02045	1.02115	1.02135	1.02160	1.02190	1.02185	1.02135	1.02175
60	1.02309	1.02369	1.02389	1.02414	1.02434	1.02419	1.02379	1.02409
65	1.02572	1.02632	1.02642	1.02667	1.02687	1.02662	1.02622	1.02642
70	1.02846	1.02906	1.02906	1.02931	1.02941	1.02916	1.02886	1.02886
75	1.03120	1.03190	1.03180	1.03195	1.03205	1.03170	1.03150	1.03130
80	1.03403	1.03484	1.03464	1.03469	1.03479	1.03434	1.03419	1.03383
85	1.03697	1.03788	1.03758	1.03743	1.03763	1.03707	1.03687	1.03647
90	1.04007	1.04092	1.04062	1.04032	1.04052	1.03991	1.03961	1.03911
95	1.04331	1.04406	1.04376	1.04336	1.04346	1.04276	1.04256	1.04185
100	1.04670	1.04720	1.04700	1.04640	1.04650	1.04570	1.04550	1.04459

8.—TABLES FOR CALCULATING THE PER CENT OF INVERT SUGAR IN PRESENCE OF SUCROSE FROM THE COPPER PRECIPITATED IN HERZFELD'S REDUCTION METHOD BY 10 GRAMS OF SAMPLE

A.—When less than one per cent of invert sugar is in sample.

MG. COPPER	PER CENT INVERT SUGAR	MG. COPPER	PER CENT INVERT SUGAR
50	.05	155	.59
55	.07	160	.62
60	.09	165	.65
65	.11	170	.68
70	.14	175	.71
75	.16	180	.74
80	.19	185	.76
85	.21	190	.79
90	.24	195	.82
95	.27	200	.85
100	.30	205	.88
105	.32	210	.90
110	.35	215	.93
115	.38	220	.96
120	.40	225	.99
125	.43	230	1.02
130	.45	235	1.05
135	.48	240	1.07
140	.51	245	1.10
145	.53		
150	.56		

B. — Invert sugar factors when more than one per cent of invert sugar is in sample.

RATIO OF SUCROSE TO INVERT SUGAR	APPROXIMATE WEIGHT OF INVERT SUGAR CORRESPONDING TO THE COPPER ACTUALLY WEIGHED ($Z = \frac{Cu}{2}$)						
	200 mg.	175 mg.	150 mg.	125 mg.	100 mg.	75 mg.	50 mg.
0 : 100	56.4	55.4	54.5	53.8	53.2	53.0	53.0
10 : 90	56.3	55.3	54.4	53.8	53.2	52.9	52.9
20 : 80	56.2	55.2	54.3	53.7	53.2	52.7	52.7
30 : 70	56.1	55.1	54.2	53.7	53.2	52.6	52.6
40 : 60	55.9	55.0	54.1	53.6	53.1	52.5	52.4
50 : 50	55.7	54.9	54.0	53.5	53.1	52.3	52.2
60 : 40	55.6	54.7	53.8	53.2	52.8	52.1	51.9
70 : 30	55.5	54.5	53.5	52.9	52.5	51.9	51.6
80 : 20	55.4	54.3	53.3	52.7	52.2	51.7	51.3
90 : 10	54.6	53.6	53.1	52.6	52.1	51.6	51.2
91 : 9	54.1	53.6	52.6	52.1	51.6	51.2	50.7
92 : 8	53.6	53.1	52.1	51.6	51.2	50.7	50.3
93 : 7	53.6	53.1	52.1	51.2	51.7	50.3	49.8
94 : 6	53.1	52.6	51.6	50.7	50.3	49.8	48.9
95 : 5	52.6	52.1	51.2	50.3	49.4	48.9	48.5
96 : 4	52.1	51.2	50.7	49.3	48.9	47.7	46.9
97 : 3	50.7	50.3	49.8	48.9	47.7	46.2	45.1
98 : 2	49.9	48.9	48.5	47.3	45.8	43.3	40.0
99 : 1	47.7	47.3	46.5	45.1	43.3	41.1	38.1

Explanation of Table B. — The cupric-reducing power of an invert sugar solution is not only dependent on the concentration of the invert sugar itself, but is also affected by the amount of sucrose present. Hence, in order to determine the factor for calculating the exact weight of invert sugar corresponding to the copper precipitated, it is necessary to have a convenient way of making a rough preliminary estimation of the invert sugar weight, so that the approximate ratio of the invert sugar to sucrose may be known.

The approximate weight of invert sugar (Z) is one half of the precipitated copper (Cu). The weight of invert sugar so found, divided by the weight of sample (W) in 50 cc. of the solution taken for Fehling test, is the approximate per cent of invert sugar (i) in the sample. The polarization of the sample (P) is taken as the per cent of sucrose. The ratio of the per cents of sucrose and invert sugar so found is expressed in parts per hundred of the sum of these percentages, and the nearest corresponding ratio ($R : Y$) is found in the left-hand column of Table B. The factor (F) in this table corresponding to this ratio, in the column under the weight approximating most nearly to the weight of invert sugar (Z), is multiplied by the weight of copper (Cu) to give the exact per cent of invert sugar (I) in the sample.

Expressed algebraically:

$$Z = \frac{Cu}{2}, \quad \frac{100 Z}{W} = i, \quad \frac{100 i}{i + P} = R, \quad 100 - R = Y, \quad I = \frac{FCu}{W}$$

OPTICAL ROTATION CONSTANTS FREQUENTLY USED

Sucrose. $[\alpha]_D^{20} = 66.67^\circ - .0095 w$ (w , 4.5 to 22.7).

(When w is taken as the weight of sugar in grams in 100 Mohr cc., the equation becomes $[\alpha]_D^{17.5} = 66.82^\circ - .0096 w$. This of course is not the true specific rotation, but is a convenient constant for saccharimetric calculations.)

Temperature formula: $[\alpha]_D^t = [\alpha]_D^{20} - .0114 (t - 20)$.

Lactose. $[\alpha]_D^{20} = 52.53^\circ$. (Very slight change with variation in concentration.) Temperature formula: $[\alpha]_D^t = [\alpha]_D^{20} - .070 (20 - t)$.

Maltose. $[\alpha]_D = 140.375^\circ - .01837 p - .095 t$.

Raffinose. $[\alpha]_D^{20} = 104.5^\circ$.

Dextrose. $[\alpha]_D^{17} = 52.50^\circ + .018796 p + .00051683 p^2$. (Little affected by temperature change.)

Invert sugar. $[\alpha]_D^{20} = -19.82 - .04 p$. $[\alpha]_D^t = -27.9 + .32 t$.

Quartz. $[\alpha]_D^t = 21.72^\circ (1 + .000143 (20 - t))$.

INDEX

- Absolute specific rotation, 245.
 Accuracy of saccharimetry, 39.
 Acid hydrolysis, laciocé, 102; laws, 198, 252; maltose, 102; raffinose, 108; speed, 252; starch, 174; suerose, 103; temperature influence, 254.
 Acidity, juice, 122.
 Affinity constants, 251; by starch hydrolysis, 255; by sucrose hydrolysis, 252.
 Alkaloids, 262; brucine, 248; cinchonidine, 264; cocaine, 265; nicotine, 266; quinine, 264; strychnine, 248; used in synthesis, 243.
 Alumina, mixture for clarifying, 90.
 Analyzer, 8.
 Andrews's temperature corrections, 43.
 Angular degree scales, 11, 29.
 Antipodes, 239; separation of, 243.
 Apparent quotient of purity, 153.
 Arabinose, 251.
 Ash, determination in beet juices, 150; glucose, 193; density correction, 194.
 Asparagine in cane juice, 125.
 Assymmetric carbon, 240.

 Bagasse, 114; fibre in, 124.
 Bag filters, 156.
 Balance, 39, 53; specific gravity, 186.
 Barrel strip, 157.
 Basic lead acetate solution, 54.
 Baumé hydrometers, 128; for glucose industry, 208; table, 285.
 Beet juice, 146; diffusion, 145.
 Beet molasses, 148; sugar from, 148.
 Beet sugar, 147; export, 111, 155; valuation, 155.
 Beets, 144; sugar determination, 149; sampling, 149.
 Bibliography, reference books, 279; papers on saccharimetry, 100; papers on starch, 221.
 Biose sugars, 101.

 Biot, 17; light wave value, 19; solution formulæ, 245.
 Boiling blank, 135.
 Bone black, 157; in saccharimetry, 91; filters, 156; spent ("spent black"), 158, 207.
 Borneol, 269.
 British gum, 219.
 Brix hydrometers (spindles), 117; convenient size, 55; reading, 118; temperature corrections, 55, 295; tables, 285; in glucose analysis, 194.
 Brown's researches in starch, 174, 192, 199, 221.
 Brucine salts, 248.

 Cadinene, 268.
 Calc spar (*see* Iceland spar).
 Calculation of errors, 39, 63.
 Calibration of flasks, Mohr cc., 56; true cc., 57.
 Calibration of saccharimeters, 41, 45.
 Camphene, 267.
 Camphor, 247, 270; in celluloid, 261.
 Cane culture, 112; fibre, 114; fibre determination, 124; mills, 114; sampling, 113; seedling, 112; sour, 123; valuation, 113.
 Cane juice, 114; classification, 125; composition, 115; extraction, 115, 123, 139; unripe, 122, 140.
 Carbonatation, 146.
 Carvone, 270.
 Caryophyllene, 268.
 Celluloid, camphor in, 261.
 Cellulose hydrolysis, 235.
 Centrifugal machines, 132, 133, 147, 156, 208.
 Centrifugal sugars, 88, 155.
 Chandler and Ricketts's detection of glucose, 226.
 Citral, 272.

- Citronellal, 270.
 Citronellool, 268.
 Clarification, beet juice, 145; cane juice, 125; Deming process, 126; errors, 96; glucose, 206; in saccharimetry, 89, 90; Horn's, 90.
 Clarifier (*see* defecator).
 Clerget method, principles, 104; original, 105; Herzfeld's, 107; Tolman's investigation, 108; applied by Leach, 232.
 Cocaine, 265.
 Concentration, formulæ, 12, 13; errors in saccharimetry, 98; influence on rotation, 5, 11, 244; juices, 128; glucose, 208.
 Confectionery analysis, 228.
 Constants of rotation, 12.
 Control-tube, 41; manipulation, 94.
 Corn for starch manufacture, 212.
 Creatinin in urine, 236.
 Creydt's raffinose method, 109; modifications, 109.
 Crystallization, in vacuum pans, 130; effect on rotation, 1; in wagons, 135.
 Crystallizers, 135.
 Crusher, cane, 114.
 Cubic centimeter, Mohr, 30, 40, 56, 58; true, 30, 40, 46, 57, 58.
 Cupric-reducing power, 172; determination, 196; relation to rotation, 183; table for acid-hydrolyzed starch, 307.
 Cupric-reduction table, Defren's, 304.

 Defecation (*see* clarification).
 Defecator, 125; tallies, 142.
 Defren, 169, 171, 200; Fehling method, 169; reduction table, 304.
 Deming process, 127.
 Density, 186; by Brix spindle, 118, 120; by pycnometer, 189; talile for sugar solutions, 285; by Westphal balance, 186; of water, 310; factors for starch products, 185; factors, assumed, 185, 191.
 Dextrose, 102, 109, 174, 175, 176, 179, 180; commercial, 208; from raffinose, 109; from sucrose, 102; from starch, 174; multirotation, 249, 251; specific rotation, 237, 314; standard solution, 163; table for Fehling determination, 304; table for determination in hydrolyzed starch, 307.
 Diamyl, 1.
 Diastase hydrolysis, 174, 183; speed, 257.
 Diffusion, 145.
 Doolittle torsion viscosimeter, 215.
 Double dilution, 97.
 Double polarization (*see* Clerget).
 Double refraction, 2; calc spar, 2; quartz, 22; glass, 2, 42.
 Double-wedge saccharimeter, 37; manipulation, 86.
 Drying of saccharine products, 152.

 Eccentricity errors, 40.
 End-point device, 16; Jelle-Cornu (Duboseq), 19; Laurent, 22; Lippich, 25; Mitscherlich, 15; transition tint, 16; triple-shade, 78; Wild, 26, 73.
 End-point observations, 59.
 Entrainment, 133.
 Enzym action, 102, 174.
 Errors, 63; clarification, 55; concentration, 99; cover glass, 42; eccentricity, 40; observation, 42; of saccharimetry, 38, 96; temperature, 43; tube-length, 39; volume, 39; weighing, 39; zero, 42, 44.
 Essential (ethereal) oils, 267; terpeneless, 272.
 Extraction, juice, 115, 139.
 Extraordinary ray, 3.

 Fehling method, 160; gravimetric, 166; Defren's, 169; Herzfeld's, 167; Pavy's, 165; volumetric, 161.
 Fehling solution, 161; Soxhlet's, 161.
 Fenchone, 270.
 Fermentation in sugarhouse, 140.
 Filre in cane, 114.
 Filar micrometer, 71.
 Filter cake, weight, 128, 138; sugar in, 127.
 Filter press, 127.
 Filtering solutions, 58.
 Filter, ray, Lippich, 11, 72, 259; bichromate, 73, 77, 99; brown glass, 78, 99.
 Fischer's sugar synthesis, 2, 240, 244.
 Flasks, 46, 54; calibration, 56.
 Fluidity of starches, 215.
 Fondants, 229.
 Eric's saccharimeter, 37.

- Galactose, 102, 251.
 Galloannic acid, 273.
 Gauges, recording, 143.
 Gauging tanks, 141.
 Gill's oleine test, 273.
 Glucose, commercial, 200; clarification, 206; colorations, 209; composition, 201; concentration, 208; determination, 192, 197, 226; dispersive effects, 77, 106; dyed, 209; in candy, 229; in preserves, 232; Japanese, 211; loss in manufacture, 212; trade forms, 201; polarization correction, 107.
 Gommelín, 220.
 Graduations, polariscope, 11, 60, 71; saccharimeter, 28, 29, 35, 46, 47, 60, 78, 100, 259.
 Granulator, 147.
 Grape sugar, 200; trade forms, 208.
 Gumdrops, 229.
 Half-shadow device, 19; sensitiveness, 21 (*see also* end point).
 Heron (*see* Brown).
 Herschel's law, 1.
 Herzfeld's double polarization, 107; invert sugar method, 167; normal weight, 46.
 Honey, 225.
 Horne's clarification, 90.
 Hortvet's maple sugar test, 228.
 Hot room, 135.
 Hydrolysis, 102; lactose, 102; maltose, 102, 255; speed, 251; starch, 174, 255, 257; sucrose, 102, 103; temperature effect, 254.
 Hydrometers, Beaumé, 128; Brix, 117; method of reading, 118.
 Iceland spar (calc spar), 2, 26, 49.
 Intensity of light in Nicol, 8; effect of sugar solution, 9.
 International Sugar Commission, 45, 46.
 Inversion, 103 (*see also* hydrolysis).
 Invert sugar, 103; determination by polarization, 108; reduction method, 167; in cane juices, 103; specific rotation, 314; standard solution, 164.
 Iodine tests in starch hydrolysis, 176.
 Jaggery, 155.
 Japanese glucose, 211.
 Jellet-Cornu prism, 19.
 Jellies, 232.
 Juice, beet, 146; cane, 114; clarifying cane, 125; clarifying beet, 146; diffusion, 145; extraction, 115; filter press, 127; sampling, 124, 141; scums, 127; unripe cane, 122, 140; weight determination, 138.
 Jujube paste, 229.
 Kenricks' tartrates method, 273.
 Lactose (*see* milk sugar), 222.
 Lamps, for saccharimeters, 52; acetylene, 52; electric, 52; gas, 52; kerosene, 52; Weisbach, 52.
 Lamps, polariscope (sodium), 13, 50; Landolt, 50; Laurent, 50, 68; new form, 51; Wiley, 50.
 Landolt, 2, 19, 25, 32, 36, 262.
 Landolt-Lippich polariscope (*see* Lippich).
 Laurent's polariscope, 22; manipulation, 68; normal weight, 30.
 Leach's methods, 226, 232.
 Le Bel (*see* Van't Hoff).
 Lemon oil, 271; variations, 271; adulterants, 271, 272; terpeneless, 272.
 Levulose, determination, 227; from raffinose, 108; sucrose, 103; multi-rotation, 251; specific rotation, 226.
 Light, beam, 6; color, 6; complementary, 10; compound, 7, 9; of *D* line, 11, 30; homogeneous (monochromatic), 7, 9; intensity, 4, 8, 30; mean yellow, 18; optical centre, 30; optically pure, 30; plane of polarization, 7; plane polarized, 4, 8; plane of vibration, 7; refraction, 22; ray, 6; rotary dispersion, 17, 32; rotation, 9; sodium, 9; total extinction, 9; undulatory theory, 5; waves (vibrations), 6; white, 9.
 Light factor, 258.
 Light filter (*see* ray filter).
 Limonene, 268.
 Linalool, 268.
 Lippich polariscope, 25, 73; manipulation, 71.
 Lippich ray filter, 11, 72, 259.

- Losses in manufacture, cane sugar, 139; chemical, 140; beet, 151; mechanical, 140; milk sugar, 223; refinery, 159.
- Maceration, 115; determination percentage, 123.
- Malt preparations, 197.
- Maltose, 102; by acid hydrolysis, 175, 199; by diastase hydrolysis, 174, 199; hydrolysis, 102, 175; in glucose, 192; determination with lactose, 224; specific rotation, 314; table for Fehling determination, 304; table for starch hydrolysis, 307.
- Maple sugar, 227.
- Masseculite, 132.
- Mean yellow light, 17.
- Mechanical filter, 146.
- Meladura, 128.
- Melter, 156.
- Menthol, 269.
- Menthone, 271.
- Milzu-ame, 211.
- Milk sugar, 222; manufacture, 223; determination, 224; separation from maltose, 224.
- Millar (*see* Brown).
- Milliliter, 39.
- Mills, cane, 114.
- Mitscherlich's polariscope, 15.
- Mohr cubic centimeter, 40, 56, 58.
- Moisture in raw sugars, 88, 152.
- Mofasses, beet, 148; cane, 101, 103; drying, 152, 153; first, 134; second, 139; sugars (second sugars), 135.
- Molecular rotation, 249.
- Montgolfier's yellow light, 19.
- Morris (*see* Brown).
- Multirotation, 249.
- Muscovado sugar, 87, 129.
- Neutralizer, 205.
- Neutralizing, glucose manufacture, 205.
- Nicol prism, 3; cleaning 48; crossed, 4; effect on light intensity, 4; "half," 78; parallel, 4.
- Nicolène, determination, 266; specific rotation, 247.
- Normal weight, 29; dextrose, 231; Duboscq, 31; lactose, 224; Laurent, 30; United States standard, 46; Ventzke, 35, 46; Wild, 31.
- Note taking, 64; blanks, 65.
- Open kettle sugar, 87, 129.
- Opposite phase, 6.
- Opic axis, 2.
- Optical analysis, 1.
- Optical centre, 30.
- Optical isomerism, 238.
- Optically active bodies, 1, 10.
- Optically pure light, 30.
- Ordinary ray, 3.
- Osmose process, 148.
- O'Sullivan, 221; density factor, 185; Fehling method, 169.
- Pasteur's researches, 1.
- Pentoses, 235, 240, 251.
- Pinene, 267.
- Plane of polarization, 7.
- Plane of vibration, 7.
- Plane polarized light, 4, 8.
- Polariscope, 5; care, 48; Duboscq (rotatometer), 19; essential parts, 14; Landolt-Lippich, 25; manipulation, 71; Laurent, 22; manipulation, 68; Mitscherlich, 15; transition-tint (Robiquet), 18; Wild (polaristrobometer), 26, 31; manipulation, 7.
- Polariscope tubes, 15, 39; commercial type, 43; control tube, 41; control-tube manipulation, 94; for inversion, 93; jacketed, 93; Landolt's, 43, 92; Laurent, 43, 92; Peiler's, 94.
- Polaristrobometer (*see* Wild polariscope).
- Polarizer, 8.
- Polarization formulæ, 12.
- Polarization of commercial sugars, 87.
- Preserves, 232.
- Prisms, Jellet-Cornu, 19; Nicol, 3.
- Pulegone, 271.
- Purity (*see* quotient of purity).
- Pyknometer, 189.
- Quartz, rotation, 1, 16; rotary dispersion, 17, 32; specific rotation, 30; temperature effect on rotation, 45.
- Quartz plates, for standardizing, 45; Laurent half-shade, 23; standard, 41; transition-tint, 17.

- Quartz-wedge compensator, 32; double, 36; Martens's, 36.
- Quinine, 262.
- Quotient of purity, 116; apparent, 153; licet products, 153; refinery method, 120; Weisberg's method, 121.
- Racemic acid, 241.
- Racemic compounds, 238; resolution, 243; symbolized, 240.
- Radiator, 170.
- Raffinose, 108; determination, 108; hydrolysis, 109; occurrence, 108, 149.
- Raw sugars, 155; sampling, 85.
- Ruy filter, bichromate, 73, 77; brown glass, 78; Lippich, 72, 73.
- Recording gauges, 143.
- Refinery losses, 159.
- Refinery methods, 155.
- Rotation, absolute specific, 245; fundamental laws, 10; relation to molecule, 249; specific, 11, 19; standard temperature, 13; very accurate determinations, 13.
- Rotatory power, specific, 11.
- Saccharimeter, 28; care, 48; double-wedge, 37, 86; Duboscq, 30, 31; errors, 39; Fric, 37; half-shade (*see* Schmidt and Hänsch); installation, 48; Laurent, 30, 68; light factor, 258; Peters, 36; quartz-wedge, 31; Schmidt and Hänsch, 35; Soleil-Duboscq, 33, 85; Soleil-Ventzke-Scheibler, 34, 83; standardizing, 41, 45, 46; triple-shade, 36, 78; United States standard, 46; Wild, 26, 31, 73.
- Saccharimeter scales, illumination, 35, 37, 48, 60; ivory, 36; nickel, 36; on quartz, 37.
- Saccharimeter graduation, 28, 29, 31, 35, 46, 47, 60, 78, 100, 259.
- Saline coefficient, 151; cane, 113.
- Sampling juice, 124; molasses, 88; raw sugar, 87; in sugarhouse, 141.
- Scales, illumination, 35, 37, 48, 60; polariscope, 11, 60, 71; readings, 60, 69, 71, 86; saccharimeter, 28, 36, 37; vernier, 61.
- Schleibler, double dilution, 97; improvements on saccharimeters, 34; moisture in starch, 216; ash method, 151.
- Second grain, 132.
- Seedling cane, 112.
- Seed selection of beets, 144.
- Sensitive tint, 33, 83.
- Shredder, 114.
- Size compounds, 218.
- Sodium light, 9, 11, 30; filtered, 11; optical centre, 11; spectrally purified, 11; wave length, 11 (*see* lamps).
- Solvent, effect on rotation, 12, 245.
- Soxhlet tube, 169.
- Soxhlet, Fehling solution, 161.
- Special laboratory apparatus, 54.
- Specific gravity, 186; by Brix spindle, 118; calculations, 190; factors, 185, 191; by pycnometer, 189; by Wespahl balance, 186.
- Specific rotatory power, 11, 19; absolute, 245; effect of salts, etc., 247; formulæ, 12; molecular, 249; solvent effect, 12, 244; table, 314; temperature effect, 12, 247; very accurate determinations, 13.
- Speed of hydrolysis, 252, 254.
- Standards, light, 11, 19, 30; saccharimetric, 30, 46.
- Starch, 173; acid, 214; alkalai, 214; chemistry, 174; corn, 178, 202; fluidity (viscosity), 215; hydrolysis, 174; iodine tests, 176; manufacture, 176, 202; moisture in, 216; paddling, 213; potato, 177; thin boiling, 177, 214; wheat, 178.
- Starch determinations, 177; diastase, 180; Hibbard, 181; Sachsse, 180.
- Steffen's molasses process, 149.
- Stock in process, 137; calculation, 139.
- Sucrose, chemistry, 101; chemically pure, 95; inversion (hydrolysis), 103; per cent by density (Brix table), 285; pipette, 118; specific rotation, 314.
- Sugar, chemistry, 101; commercial, 87; effect on polarized light, 9; export (beet), 111, 133; grape, 200; hydrolysis, 101, 251; in urine, 236; multirotation, 249.
- Sulphites in glucose, 207.
- Sulphuring, beet juice, 146, 147; cane juice, 125.
- Synthetic compounds, inactive, 243; made active, 243.

- Tables, Brix, 285; Beaumé, 285; Brix temperature correction, 295; carbohydrates of acid-hydrolyzed starch, 307; cupric-reducing power of acid-hydrolyzital starch, 307; Dufrenoy's copper oxide equivalents, 304; density of sugar solutions, 285; density of water, 310; density factors for hydrolyzed starch, 195; Herzfeld's double polarization factors, 107; Herzfeld's Fehling invert sugar equivalents, 312, 313; Saare's moisture in starch, 217; Schmitz sacrose solution, 296; Schmitz saccharimeter correction, 99; volume of sugar solutions, 311; Weisberg's quotient of purity correction, 154.
- Tartaric acid, 241; specific rotation, 247, 263.
- Tartrates, Kenricks' method, 273.
- Temperature, effect on rotation, 11, 45, 247; effect on hydrolysis, 254; errors in saccharimetry, 43; standard for polarizing, 12, 13, 45; standard for starch analysis, 193; standard for sugar analysis, 43.
- Terebenthene (*see* pinene).
- Terpeneol, 269.
- Terpentine in lemon oil, 271; specific rotation, 247.
- Thujone, 270.
- Tolman's double polarization formulae, 108.
- Total solids, by drying, 152; Brix spindle, 116; Weisberg's method, 153.
- Transition tint, 17.
- Transition-tint plate, 16.
- Treacle, 157.
- Trier, 88.
- Undulation (*see* wave).
- Undulatory theory, 5.
- Urine, sugar in, 236; creatinin in, 236; polarization, 237.
- Van't Hoff-Le Bel theory, 1, 238, 249.
- Veinier scale, 61; method of reading, 61.
- Viscosity of cane juices, 122; starches, 214; dextrans, 220.
- Viscosimeter, 215.
- Water for polarimetry, 55; density table, 310.
- Wave, 6.
- Wave length, 67; half, 6; sodium light, 11.
- Weber and McPherson, glucose correction, 107.
- Wedge (*see* quartz wedge).
- Weisberg, purity method, 121; correction table, 154.
- Whey, 222.
- White sugar, 125.
- Wiley, double dilution, 97; glucose research, 183; lactose clarification, 224; levulose determination, 227; starch determination, 80; temperature correction, 44.
- Xylose, 235, 251.
- Yellow light, 9; mean, 18, 19.
- Zero error, 42, 44; affected by temperature, 44; when ignored, 45.